

INSTALLATION INSTRUCTIONS

**S6 RUNNING BOARDS
2019 DODGE RAM 1500 CREW CAB**

PARTS LIST:

1	Driver/left side S6 Running Board	6	8mm x 35mm Double Bolt Plates
1	Passenger/right side S6 Running Board	30	8mm x 24mm x 2mm Flat Washers
6	Universal Mounting Brackets (left or right)	30	8-1.25mm Nylon Lock Nuts

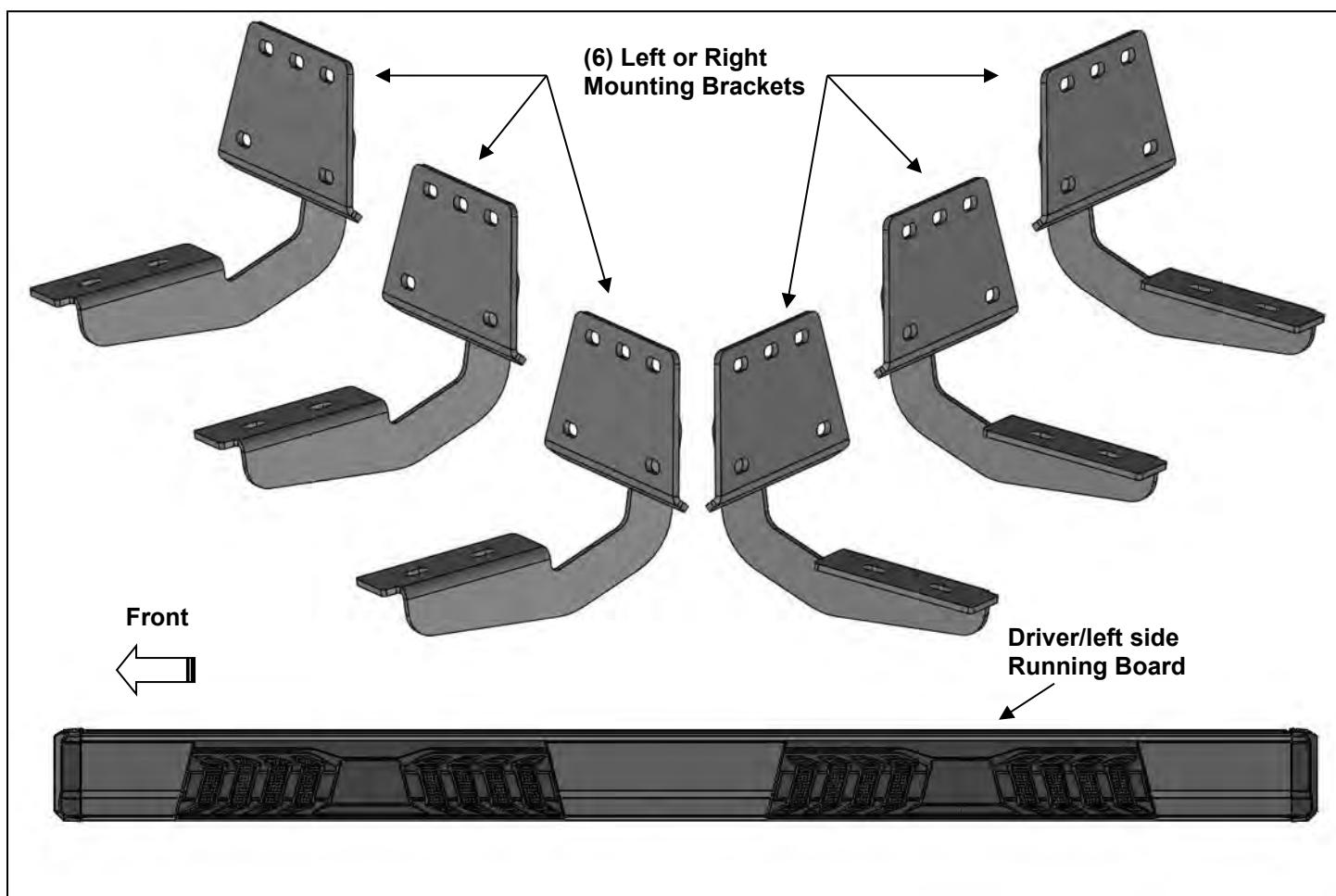

PROCEDURE:

REMOVE CONTENTS FROM BOX. VERIFY ALL PARTS ARE PRESENT. READ INSTRUCTIONS CAREFULLY BEFORE STARTING INSTALLATION. ASSISTANCE IS RECOMMENDED.

1. Start the installation under the driver side of the vehicle. Locate the front (3) factory studs along the inner side of the body panel, **(Figure 1)**.
2. Select (1) Mounting Bracket. **NOTE:** All (6) Brackets are universal and will fit left or right side. Attach the Mounting Bracket to the (3) factory studs with (3) 8mm Flat Washers and (3) 8mm Nylon Lock Nuts, **(Figure 2)**. Leave brackets loose at this time.
3. Repeat **Steps 1 & 2** to install the Universal Brackets in the center and rear mounting locations along the body panel, **(Figures 3 & 4)**.
4. Carefully unwrap and select the Driver/left side Running Board. Use the illustration above to help determine the correct Running Board. **NOTE:** The front stepping pad on the Running Board is closer to the end. Place the Running Board on top of the Brackets. **IMPORTANT:** Do not slide, (front to back), the Running Board on the Brackets or damage to the finish may result. Locate the channel opening in the bottom of the Running Board. Select (3) 6mm Double Bolt Plates, **(Figure 5)**. Insert the Bolt Plates into the channel in the bottom of the Running Board closest to the Brackets, **(Figure 6)**. Lift the Running Board up and guide the studs through the Brackets.

5. Attach the Running Board to the Brackets with (6) 8mm Flat Washers and (6) 8mm Nylon Lock Nuts, (**Figures 7 & 8**).
6. Level and adjust the Running Board as necessary and fully tighten all hardware.
7. Repeat **Steps 1—6** for Passenger/right side Running Board Installation.
8. Do periodic inspections to the installation to make sure that all hardware is secure and tight.

To protect your investment, wax this product after installing. Regular waxing is recommended to add a protective layer over the finish. Do not use any type of polish or wax that may contain abrasives that could damage the finish. Mild soap may be used also to clean the Running Board.

Driver/left Side Installation Pictured

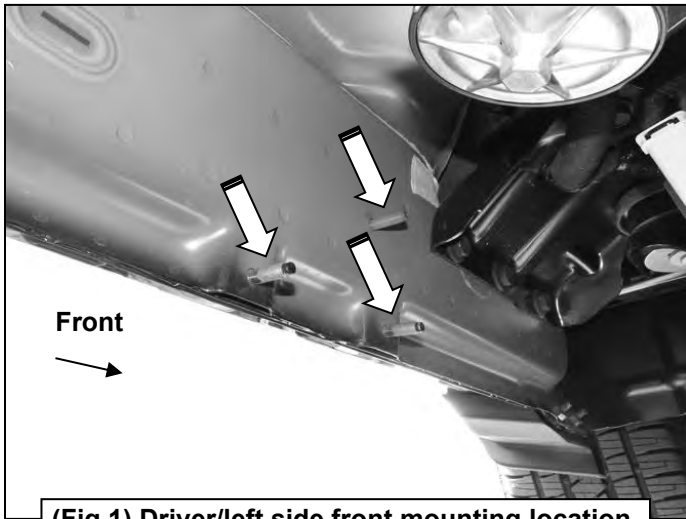

(Fig 1) Driver/left side front mounting location

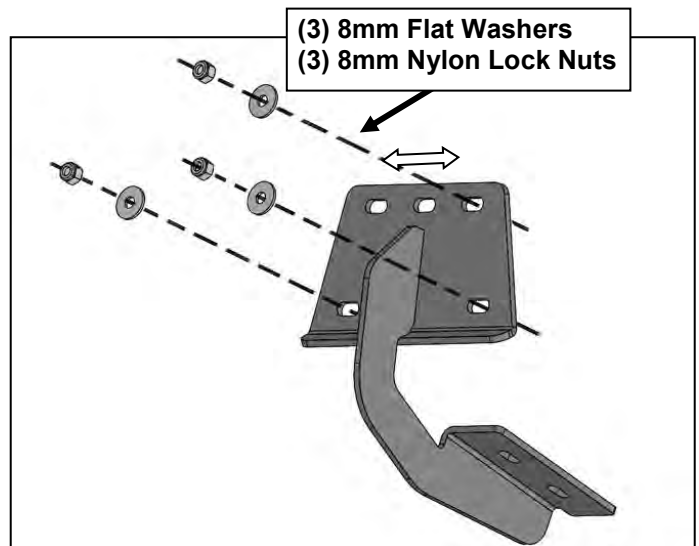

(Fig 2) Attach Bracket to the (3) studs

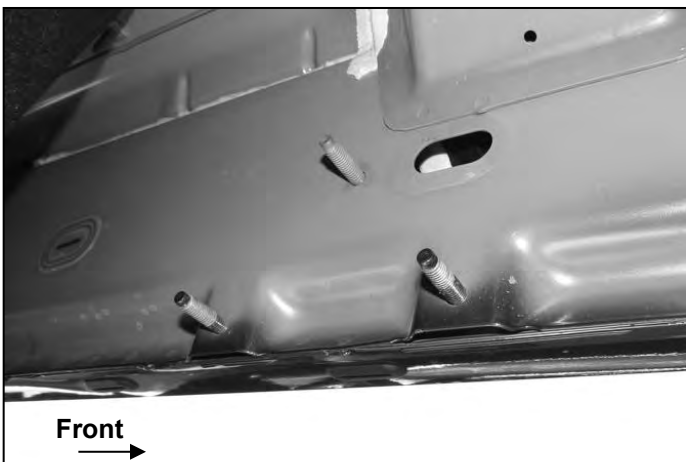

(Fig 3) Driver/left side center mounting location

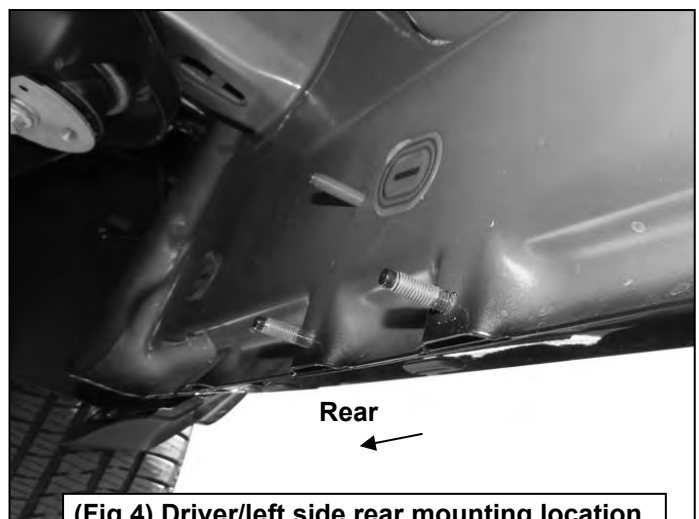

(Fig 4) Driver/left side rear mounting location

Driver/left Side Installation Pictured

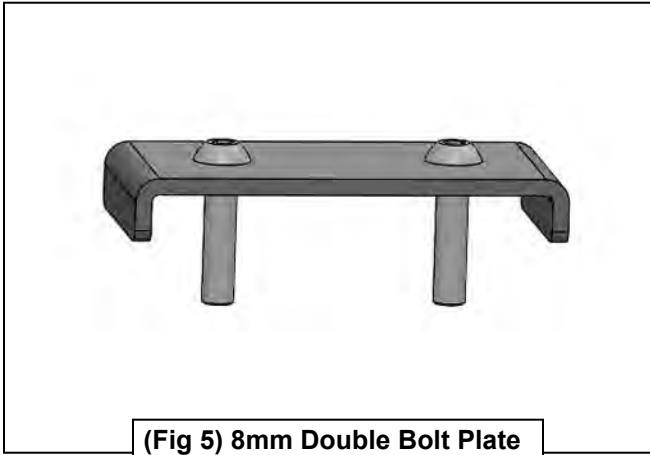

(Fig 5) 8mm Double Bolt Plate

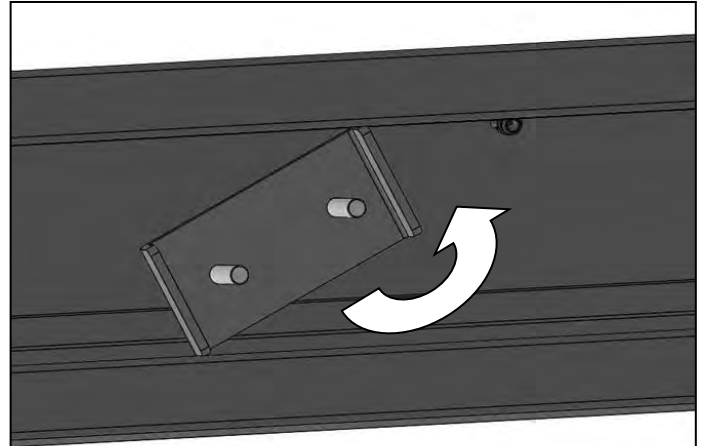

(Fig 6) Insert 8mm Double Bolt Plate through the channel in the bottom of the Running Board

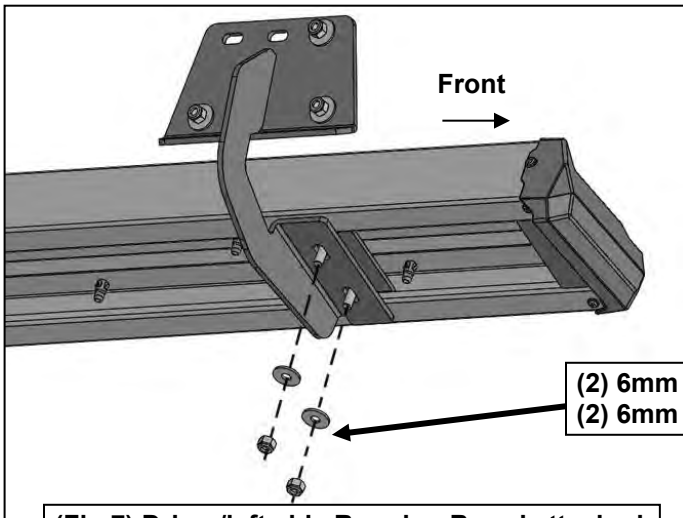

- (2) 6mm Flat Washers
- (2) 6mm Nylon Lock Nuts

(Fig 7) Driver/left side Running Board attached to Mounting Bracket at the front location

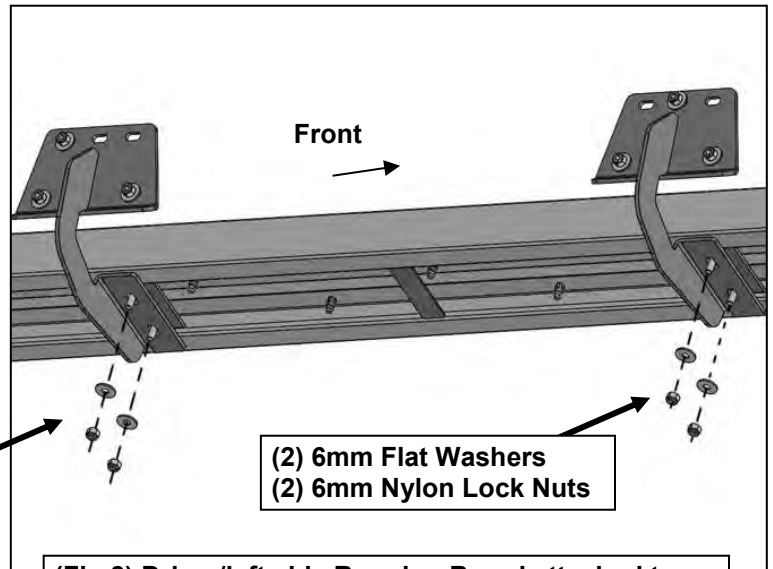

- (2) 6mm Flat Washers
- (2) 6mm Nylon Lock Nuts

- (2) 6mm Flat Washers
- (2) 6mm Nylon Lock Nuts

(Fig 8) Driver/left side Running Board attached to Mounting Brackets at the center and rear locations