

INSTALLATION INSTRUCTIONS

3" 90 DEGREE BENT END SIDEBARS

2019 DODGE RAM 1500 CREW CAB

EXCLUDES BODY LIFT KIT

PARTS LIST:

1	Driver/left side 3" 90 deg. Bent End Sidebar	1	Passenger/right side Rear Support Bracket
1	Passenger/right side 3" 90 deg. Bent End Sidebar	4	1/2" x 2" Hex Bolts
2	Driver Front/ Passenger Rear Mounting Brackets	4	1/2" x 1-1/2" x 1/8" Flat Washers
2	Passenger Front/Driver Rear Mounting Brackets	4	1/2" Lock Washers
1	Driver/left side Front Support Bracket	12	8-1.25mm Nylon Lock Nuts
1	Passenger/right side Front Support Bracket	12	8mm x 24mm x 2mm Flat Washers
1	Driver/left side Rear Support Bracket		

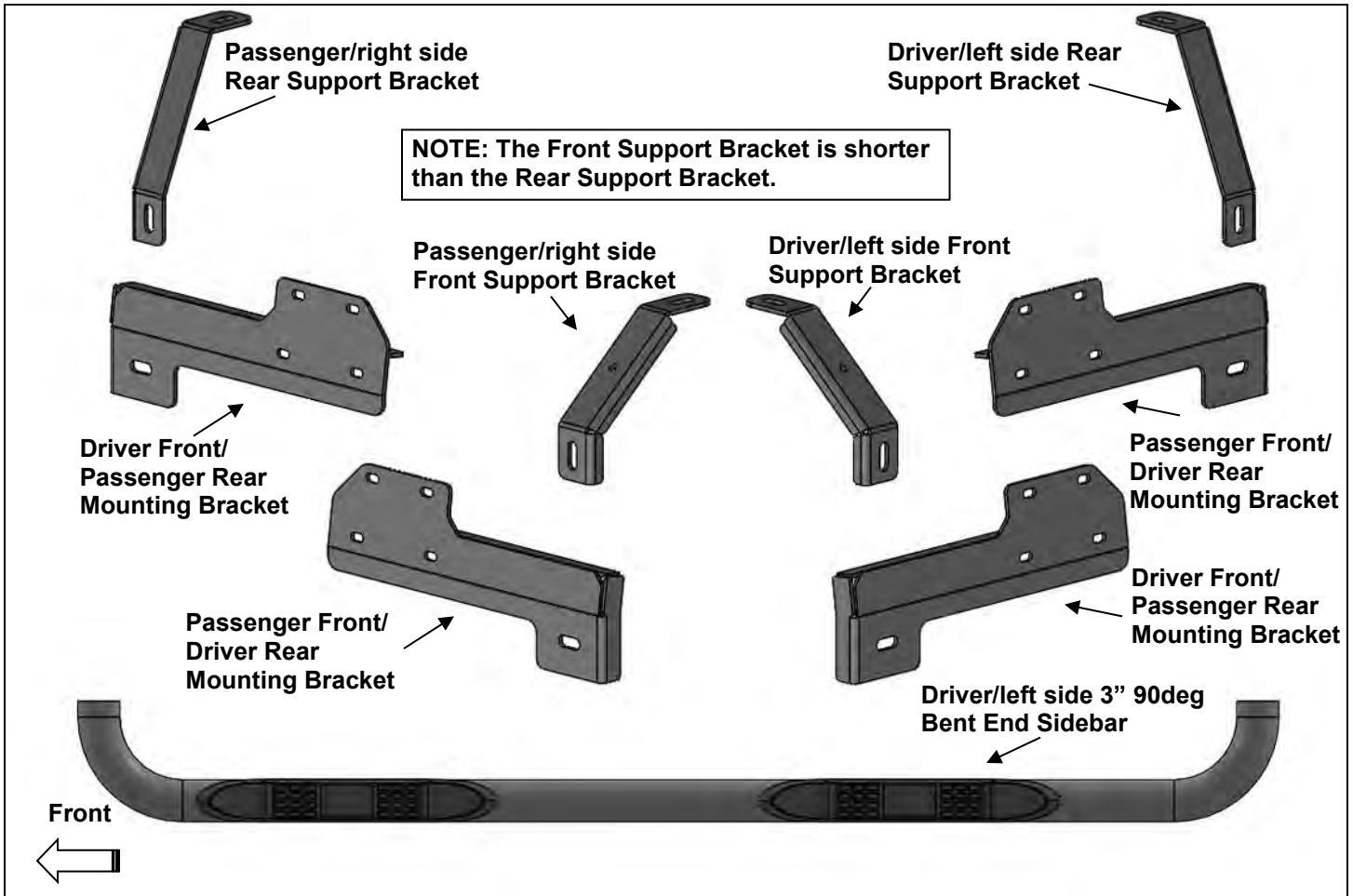

PROCEDURE:

REMOVE CONTENTS FROM BOX. VERIFY ALL PARTS ARE PRESENT. READ INSTRUCTIONS CAREFULLY BEFORE STARTING INSTALLATION. ASSISTANCE IS RECOMMENDED.

1. Start the installation under the driver/left side of the vehicle. Locate the front (3) factory studs along the inner side of the body panel, **(Figure 1)**. **NOTE:** Chase threads on the studs first before installing Brackets to remove paint buildup.
2. Select (1) Driver/left side Front Mounting Bracket. Attach the Mounting Bracket to the (3) factory studs with (3) 8mm Flat Washers and (3) 8mm Nylon Lock Nuts, **(Figures 2 & 3)**. Leave Bracket loose at this time.
3. Locate the front body mount, **(Figure 4)**. Remove the factory body bolt and factory washer, **(Figure 5)**. **NOTE:** Chase thread on body bolt to remove paint buildup before reinstalling. Select the Driver/left side Front Support Bracket, **(Figure 6)**. Line up the upper slot on the Bracket with the body bolt hole. Reuse the factory body bolt and washer to attach the Bracket to the top of the body mount, **(Figure 7)**.

4. Move to the rear mounting location, (**Figure 8**). Repeat **Steps 2 & 3** for Driver/left Rear Mounting Bracket and Driver/left Rear Support Bracket installation, (**Figures 9 & 10**).
5. Carefully unwrap and select the Driver/left 3" Sidebar. Use the illustration above to help identify the correct Sidebar. With assistance, line up the front end of the tube with the front Bracket slots, (**Figure 11**). Use (2) 1/2" Hex Bolts, (2) 1/2" Lock Washer and (2) 1/2" Flat Washers to attach the front end of the Sidebar tube to the Front Brackets, (**Figures 11 & 12**). Snug but do not tighten hardware at this time.
6. Move to the rear end of the Sidebar tube and repeat **Step 5** to attach the Sidebar to the rear Brackets, (**Figure 13**).
7. Level and adjust the Sidebar as necessary and fully tighten all hardware.
8. Repeat **Steps 1—7** for Passenger/right 3" Sidebar installation.
9. Do periodic inspections to the installation to make sure that all hardware is secure and tight.

To protect your investment, wax this product after installing. Regular waxing is recommended to add a protective layer over the finish. Do not use any type of polish or wax that may contain abrasives that could damage the finish. Mild soap may be used also to clean the Sidebar.

Driver/left Side Installation Pictured

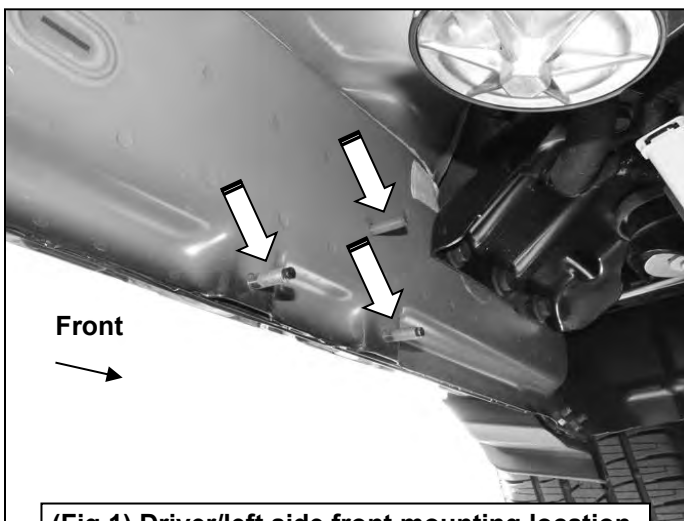

(Fig 1) Driver/left side front mounting location

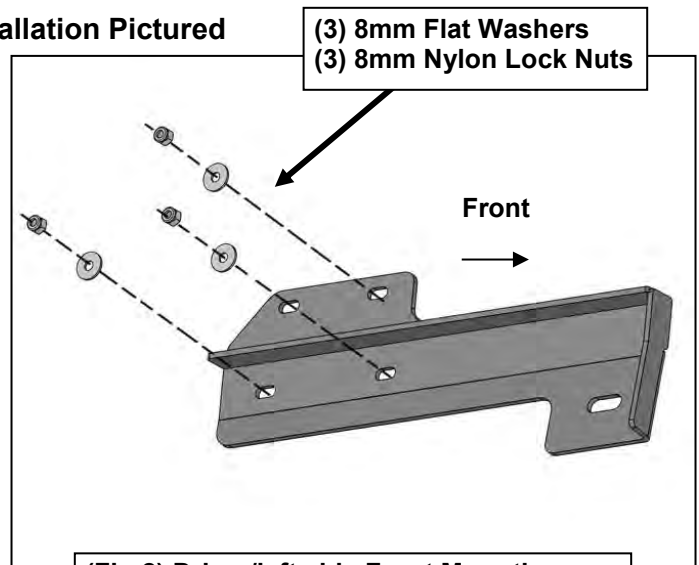

(Fig 2) Driver/left side Front Mounting Bracket attached to Side Panel illustrated

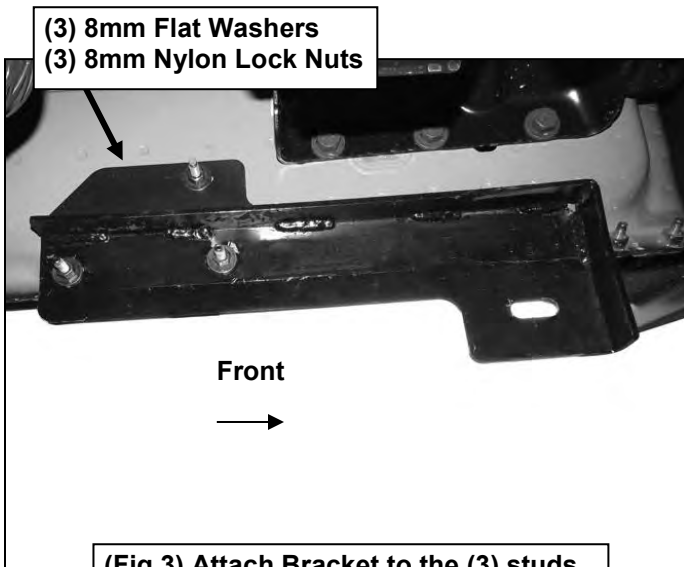

(Fig 3) Attach Bracket to the (3) studs

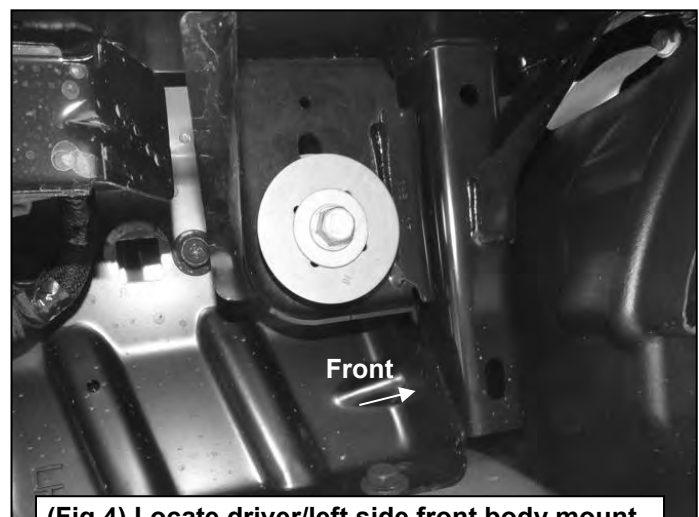

(Fig 4) Locate driver/left side front body mount

Driver/left Side Installation Pictured

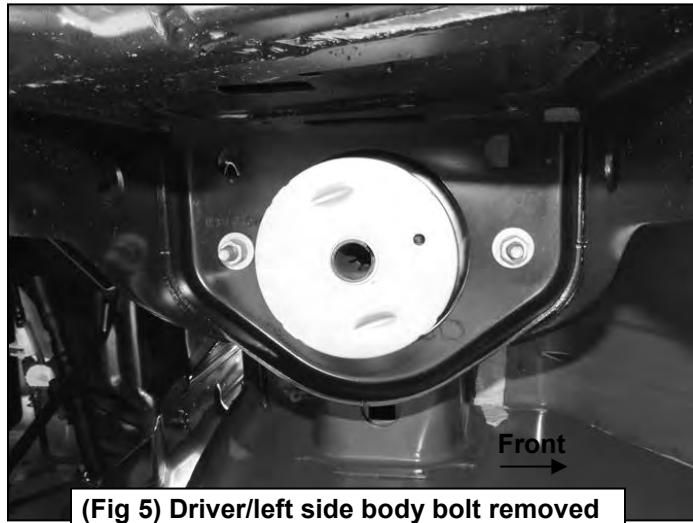

(Fig 5) Driver/left side body bolt removed

NOTE: The Front Support Bracket is shorter than the Rear Support Bracket.

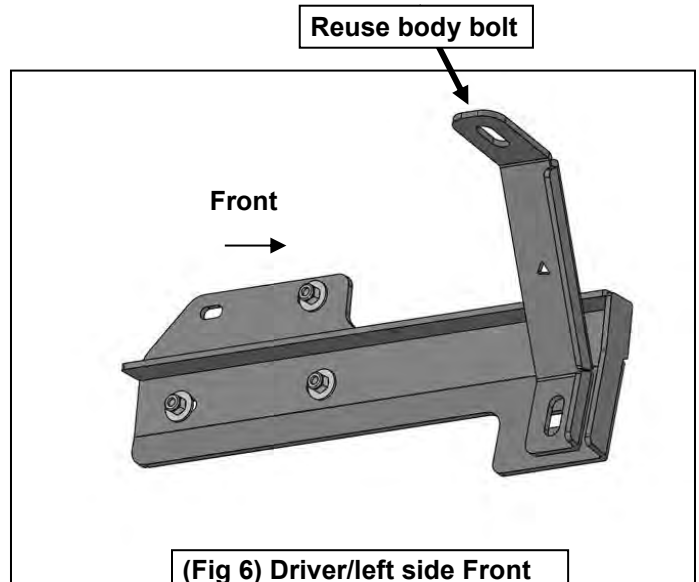

(Fig 6) Driver/left side Front Support Bracket illustrated

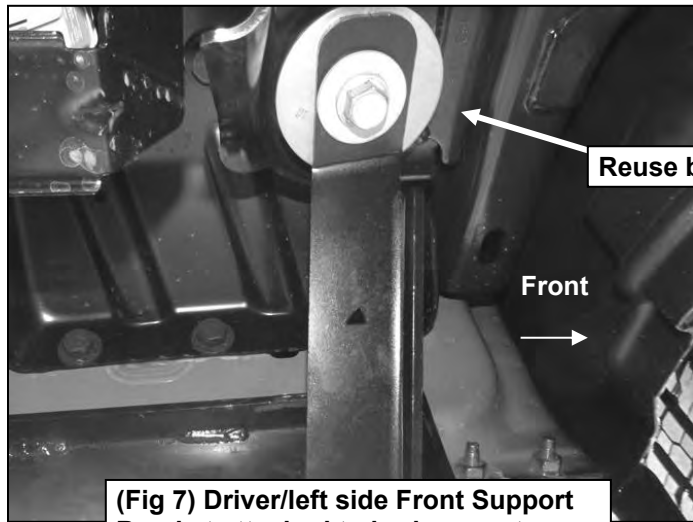

(Fig 7) Driver/left side Front Support Bracket attached to body mount

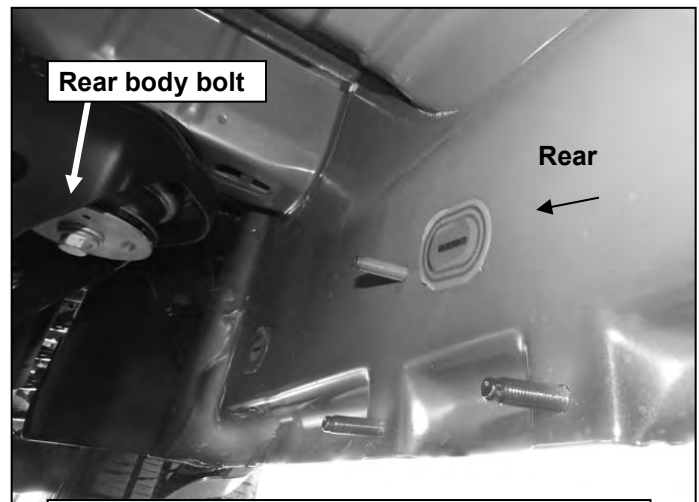

(Fig 8) Driver/left side rear mounting location

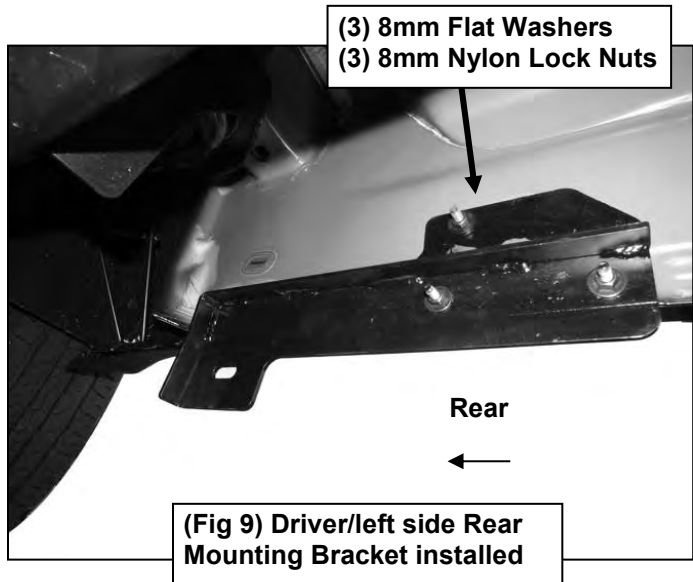

(Fig 9) Driver/left side Rear Mounting Bracket installed

**(3) 8mm Flat Washers
(3) 8mm Nylon Lock Nuts**

Driver/left Side Installation Pictured

