

PARTS LIST: R109752

1	Driver/left side NB1 Running Board	24	10mm x 27mm x 3mm Flat Washers
1	Passenger/right side NB1 Running Board	12	10mm Nylon Lock Nuts
6	Universal Brackets	18	8mm x 24mm x 2mm Flat Washers
12	10mm x 35mm Hex Bolts	18	8-1.25mm Nylon Lock Nuts

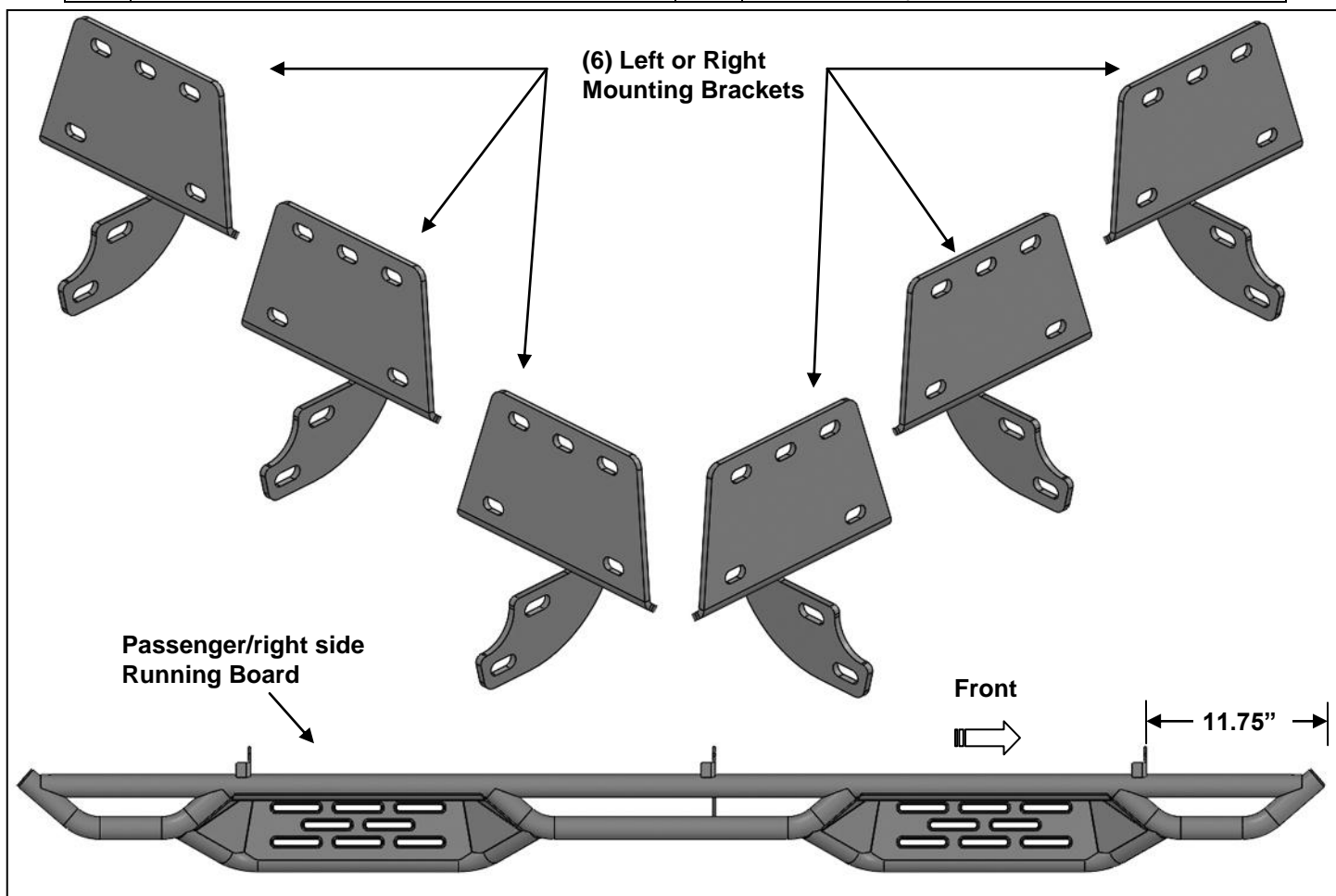

PROCEDURE:

REMOVE CONTENTS FROM BOX. VERIFY ALL PARTS ARE PRESENT. READ INSTRUCTIONS CAREFULLY BEFORE STARTING INSTALLATION. ASSISTANCE IS RECOMMENDED.

1. Start the installation under the passenger side of the vehicle. Locate the front (3) factory studs along the inner side of the body panel, **(Figure 1)**. **NOTE:** Chase threads on the studs first before installing Brackets to remove paint buildup.
2. Select (1) Mounting Bracket. **NOTE:** All (6) Brackets are universal and will fit left or right side. Attach the Mounting Bracket to the (3) factory studs with (3) 8mm Flat Washers and (3) 8mm Nylon Lock Nuts, **(Figures 2 & 3)**. Leave brackets loose at this time.
3. Repeat **Steps 1 & 2** to install the Universal Brackets in the center and rear mounting locations along the body panel, **(Figures 4 – 7)**.
4. Carefully unwrap and select the Passenger/right side Running Board. Use the illustration above to help identify the correct Running Board. Position the mounting tabs on the Running Board to the rear side of the Mounting Brackets, **(Figure 8)**.
5. Attach the Running Board to the Brackets using (6) 10mm Hex Bolts, (12) 10mm Flat Washers and (6) 10mm Nylon Lock Nuts, **(Figures 9 – 11)**. Do not tighten hardware at this time.
6. Level and adjust the Running Board as necessary and fully tighten all hardware.

7. Repeat **Steps 1—6** for Driver/left side Running Board installation.
8. Do periodic inspections to the installation to make sure that all hardware is secure and tight.

To protect your investment, wax this product after installing. Regular waxing is recommended to add a protective layer over the finish. Do not use any type of polish or wax that may contain abrasives that could damage the finish. Mild soap may be used also to clean the Running Board.

Passenger/right Side Installation Pictured

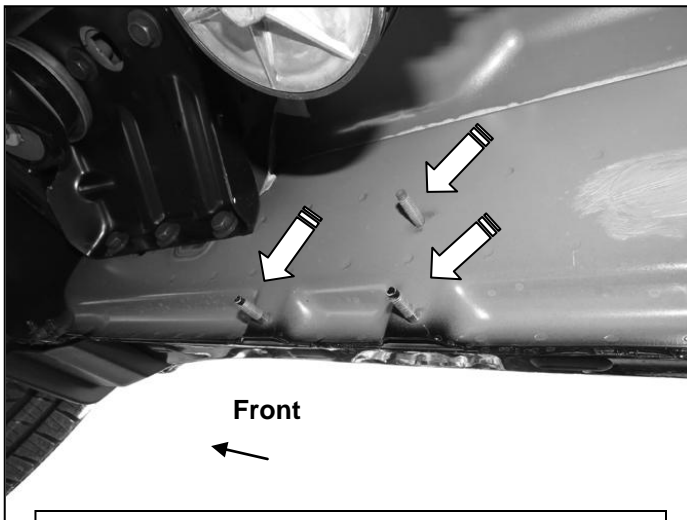

(Fig 1) Passenger side front mounting location

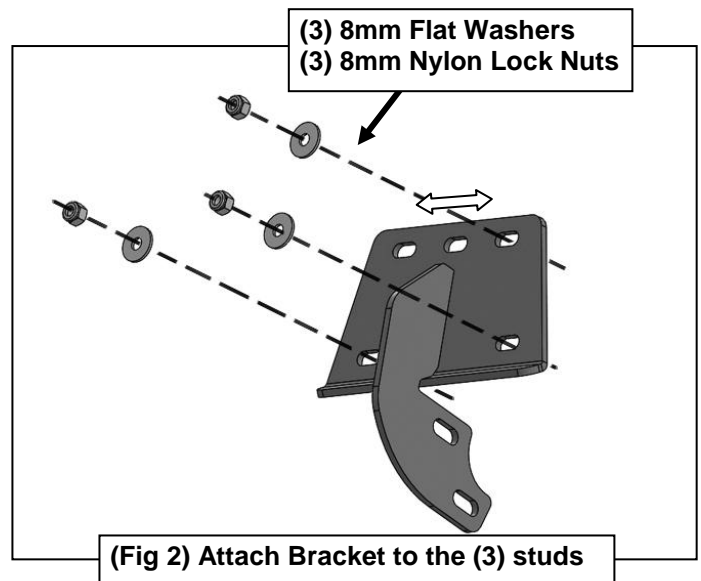

(Fig 2) Attach Bracket to the (3) studs

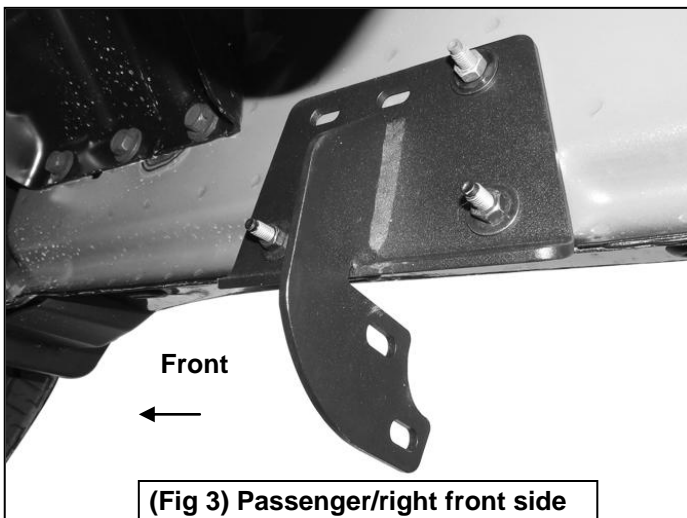

(Fig 3) Passenger/right front side with Mounting Bracket installed

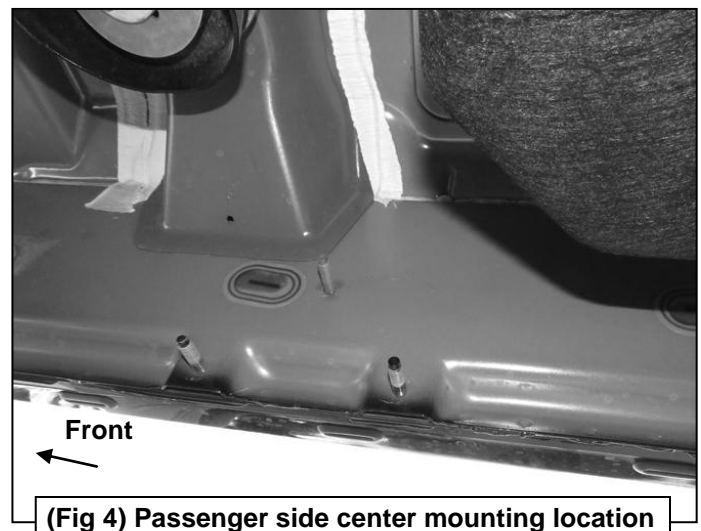

(Fig 4) Passenger side center mounting location

Passenger/right Side Installation Pictured

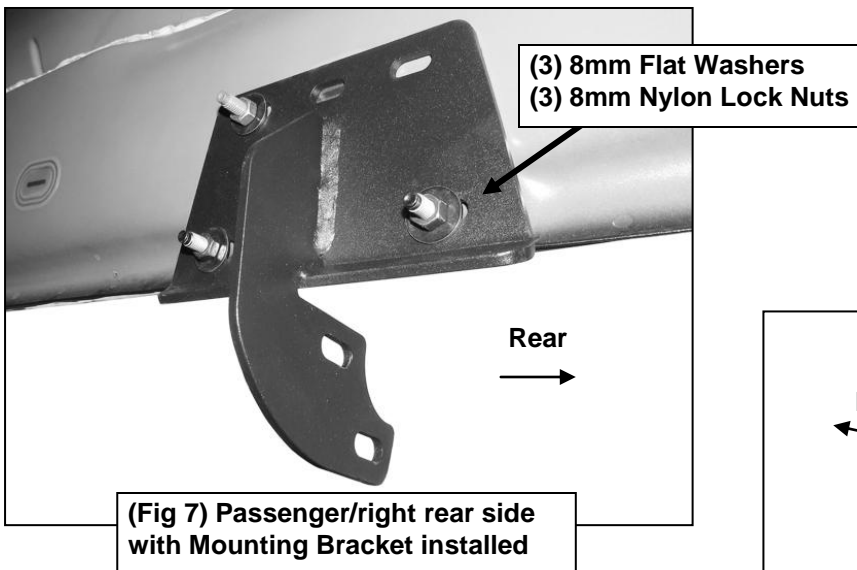
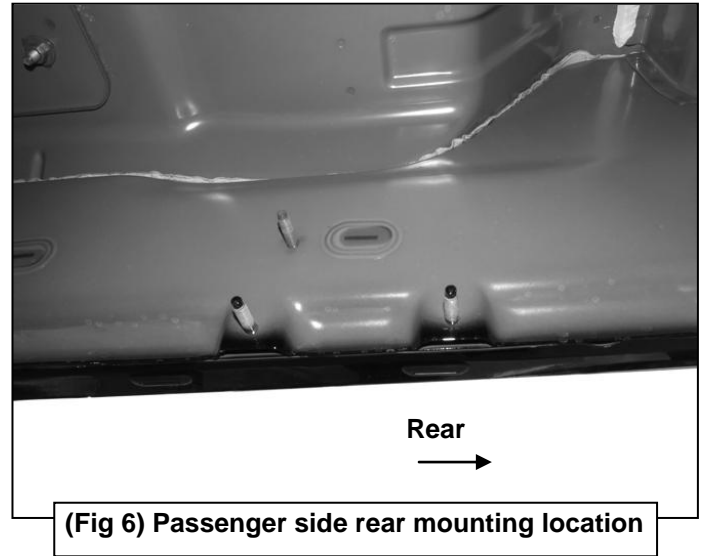
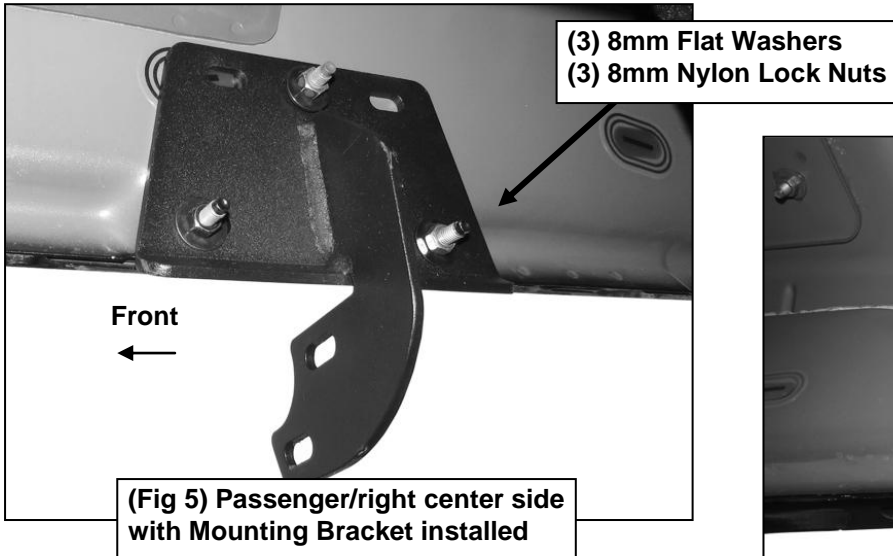

- (2) 10mm Hex Bolts
- (4) 10mm Flat Washers
- (2) 10mm Nylon Lock Nuts

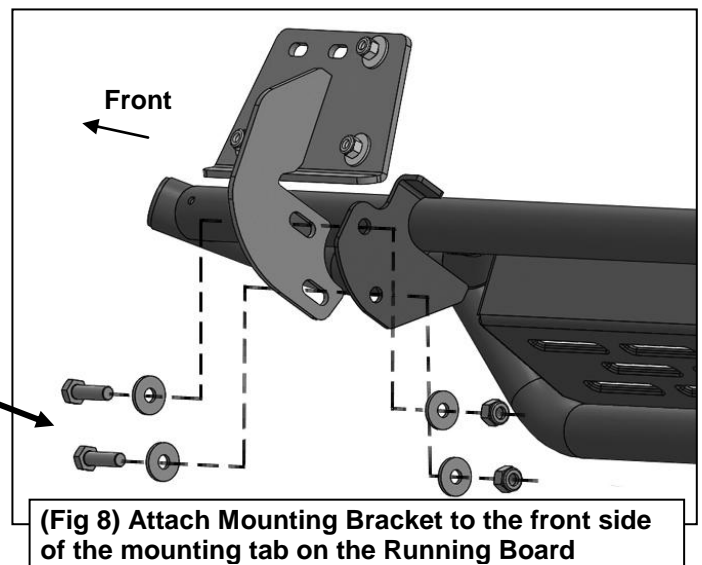

Passenger/right Side Installation Pictured

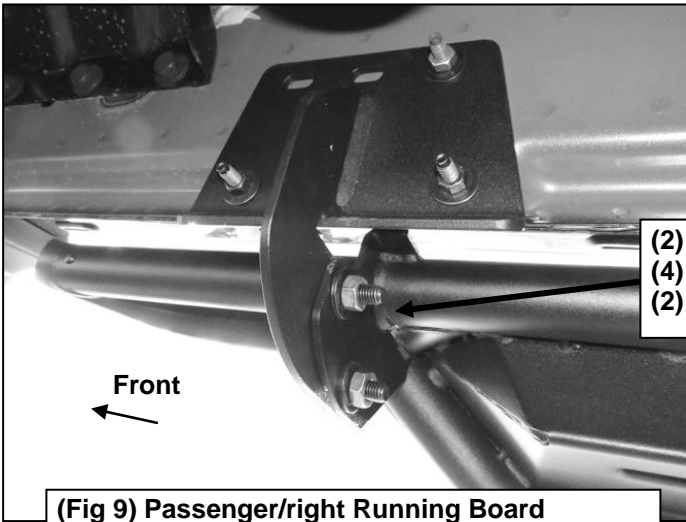

- (2) 10mm Hex Bolts
- (4) 10mm Flat Washers
- (2) 10mm Nylon Lock Nuts

(Fig 9) Passenger/right Running Board attached to front Mounting Bracket pictured

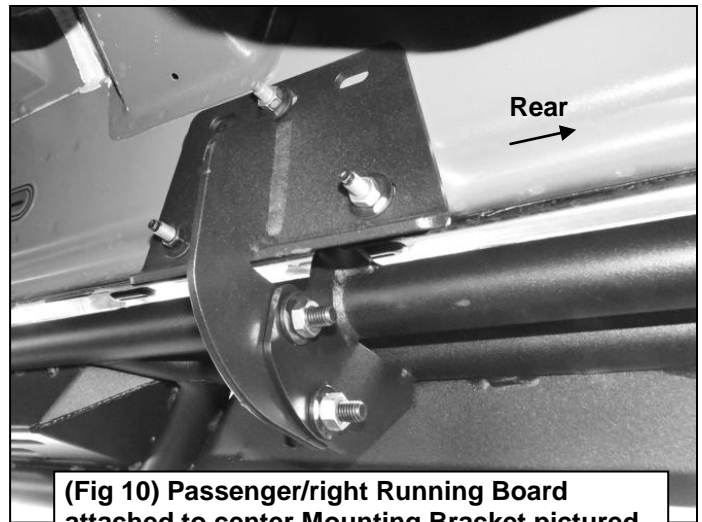

(Fig 10) Passenger/right Running Board attached to center Mounting Bracket pictured



- (2) 10mm Hex Bolts
- (4) 10mm Flat Washers
- (2) 10mm Nylon Lock Nuts

(Fig 11) Passenger/right Running Board attached to rear Mounting Bracket pictured

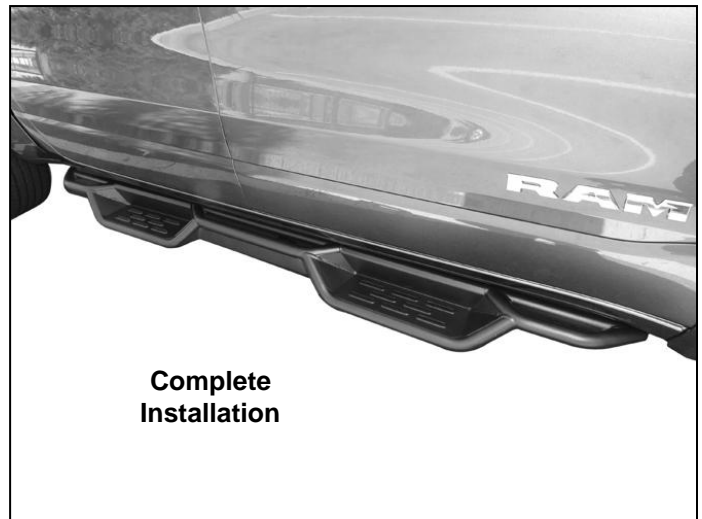

Complete Installation