

KEY TO COMPONENTS

- A. 1 ea. Rear bumper
- B. 4 ea. Hex head bolts M12x1.75x40mm
- C. 4 ea. Hex head nut M12x1.75
- D. 8 ea. Flat washer M12
- E. 4 ea. Split washer M12
- F. 2 ea. LED markers

TOOLS NEEDED

- Socket drive
- 15mm socket
- 18mm deep socket

HD Rear Bumper Installation Instructions PART NUMBER R109762 FITS Dodge Ram 1500 13-18

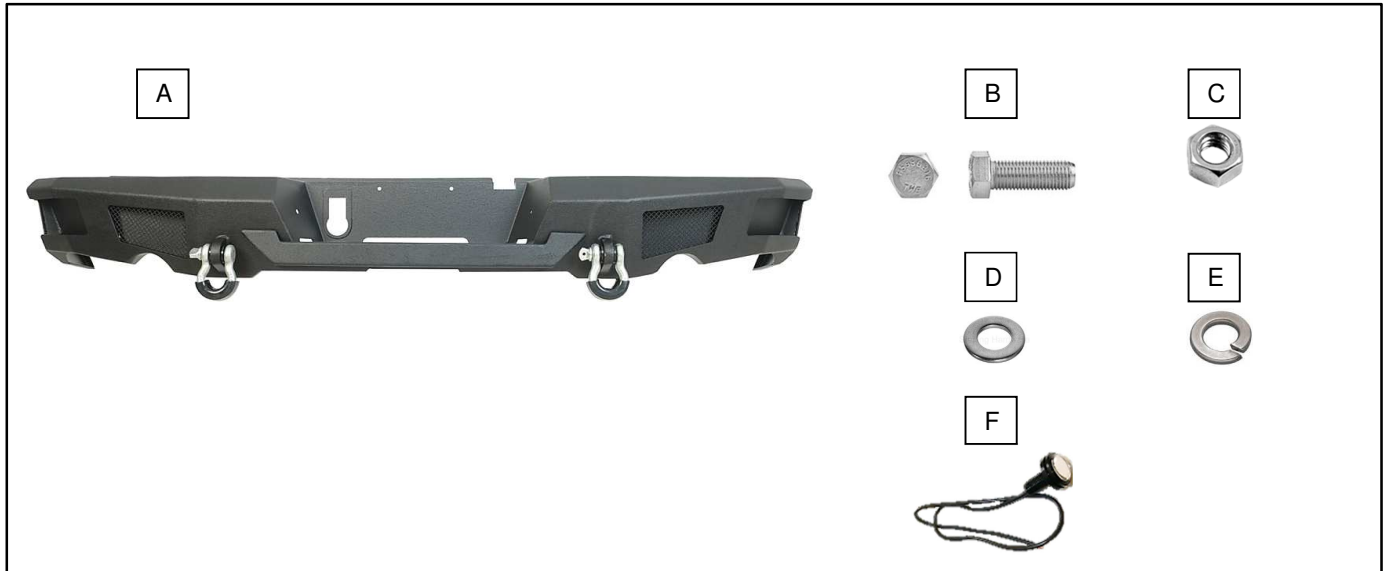

Please take a few minutes to read and thoroughly familiarize yourself with the installation procedures outlined in this manual. Following the steps as outlined will save you time and help reduce mistakes. Once the instructions are reviewed, if you feel that you are not capable of safely installing the parts seek the help of a qualified installation expert to help you complete the job. The manufacture is in no way responsible for any personal injury or vehicle damage that may occur during the installation.

ELECTRICAL INSTALLATION



The rear bumper comes complete with LED lights which need to be connected to a power source. Failure to properly make these connections could result in damage to the LED lights and/or your vehicle and may result in personal injury. If you are not qualified to make the proper connections, we highly recommend that you contact an installation expert to complete the connections.

California Proposition 65 Warning!

This product includes a power cord which may contain lead a chemical known to the State of California to cause cancer and birth defects or other reproductive harm. For more information go to www.P65Warnings.ca.gov.

FACTORY BUMPER REMOVAL



Step 1.
Working underneath the vehicle. Locate and disconnect factory license plate light. Repeat for other side.



Step 2.
Using a 18mm socket locate and remove 2 factory bolts holding the bumper onto vehicle. Repeat for other side. Discard factory hardware.



Step 3.
Using a 15mm socket locate and remove 2 factory bolts behind the vehicle's license plate. Discard hardware.



Step 4.
Locate and remove locking clip from trailer harness. Remove factory bumper from vehicle.

FACTORY BUMPER REMOVAL continued



Step 5.
Proceed to your work bench. Working behind the bumper locate and remove hitch harness by firmly pressing on both clips as shown. Remove hitch harness from factory bumper. Set hitch harness aside for later use.

INSTALLING NEW BUMPER



Step 1.
With help from an assistant place the supplied bumper (A) onto vehicle. Line up the bumper mounting holes with the vehicle frame holes.



Step 2.
Locate and place supplied hex head bolt M12x1.75x40mm (B) with supplied flat washer M12 (D) from behind the bumper hole and through the vehicles frame hole. Slide a supplied flat washer M12 (D) and a supplied split washer M12 (E) onto bolt. Start a supplied hex head bolt M12x1.75 (C) at the end of bolt. Tighten down using a 18mm wrench. Repeat step for other bolt. Repeat same steps for other side.



Step 3.
Place factory hitch harness into shaped hole in bumper. Reinstall the hitch receiver locking clip onto hitch harness.

INSTALLING NEW BUMPER continued

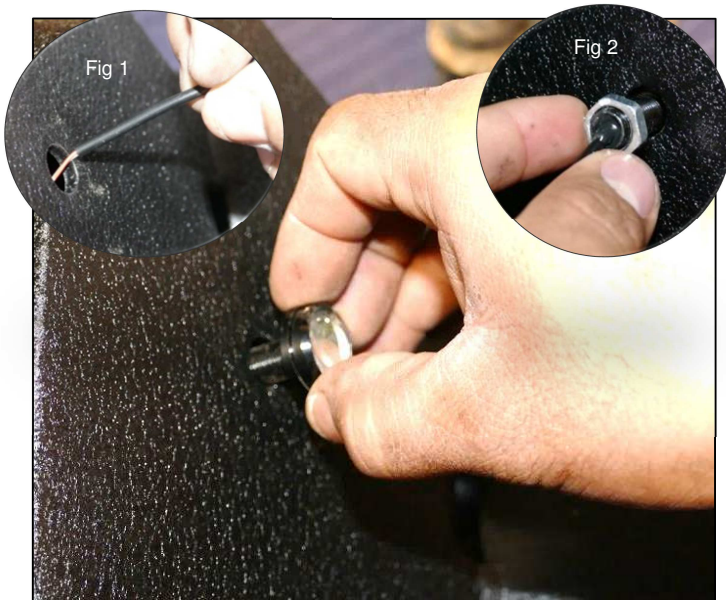

Step 4. Working on work bench.
Feed supplied LED marker (F) cable through license plate light hole fig 1. Start supplied nut at the end of light shown in fig 2. Finger tighten only. Repeat step for other side LED light.



Step 5
Locate the D-Ring shackles provided and mount them to the D-Ring tabs on the bumper.



Proceed to make electrical connections for the LED lights. If you are not qualified to make the proper connections, we highly recommend that you contact an installation expert to complete the connections.

This completes the installation.