

**PARTS LIST:**

1	LD1 Front Bumper Assembly	10	12mm Hex Nuts
1	Driver/left Frame Mounting Bracket	6	10-1.5mm x 35mm Hex Bolts
1	Passenger/right Frame Mounting Bracket	12	10mm x 27mm OD x 3mm Flat Washers
2	Spacers for Frame Brackets	6	10mm Lock Washers
2	Tow Hook Extension Brackets	6	10mm Hex Nuts
4	Spacers (tow hooks)	2	8mm x 25mm Hex Bolts
1	License Plate Bracket	2	8mm x 16mm Hex Bolts
2	Plastic Plugs for License Plate	6	8mm x 24mm x 2mm Flat Washers
1	Driver/left "L" Bracket (center LED light)	4	8mm Lock Washer
1	Passenger/right "L" Bracket (center LED light)	2	8mm Hex Nut
4	12mm x 140mm Hex Bolts	2	6mm x 20mm Button Head Bolts
2	12mm x 30mm Double Bolt Plates	4	6mm x 18mm x 1.6 Flat Washers
2	12mm x 35mm Single Bolt Plates	2	6mm Nylon Lock Nuts
14	12mm x 32mm OD x 3mm Flat Washers	1	6mm Wrench
10	12mm Lock Washers	10	Nylon Wire Ties

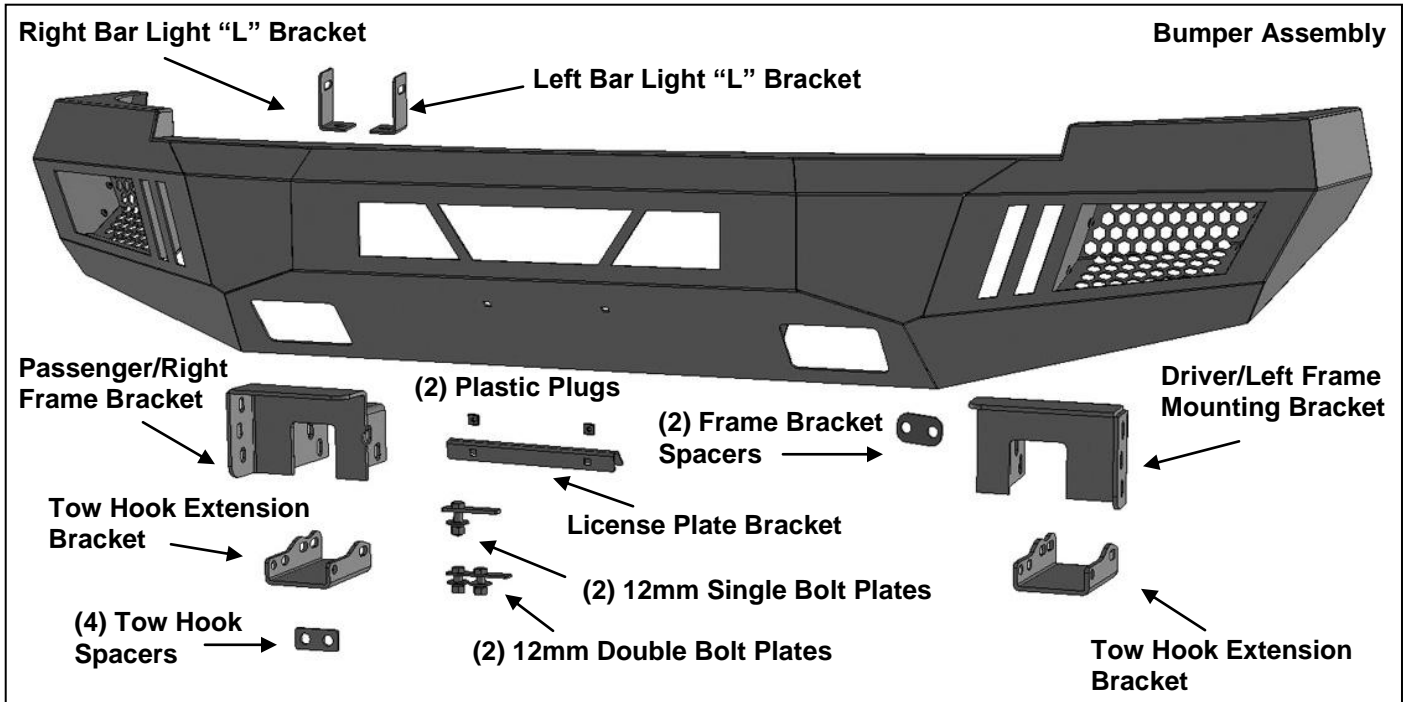

**PROCEDURE:**

**REMOVE CONTENTS FROM BOX. VERIFY ALL PARTS ARE PRESENT. READ INSTRUCTIONS CAREFULLY BEFORE STARTING INSTALLATION. ASSISTANCE IS HIGHLY RECOMMENDED TO AVOID POSSIBLE INJURY OR DAMAGE TO THE VEHICLE.**

1. Remove the license plate and bracket. On models with factory fog lights, unplug the wiring harness and move the harness away from the bumper, **(Figure 1)**.
2. From behind the bumper, remove the bumper supports attaching the outer ends of the bumper to each side of the frame.
3. Place blocks or jack stands under the front bumper to support it during mounting bolt removal. Once the bumper has been safely supported, remove the (4) large factory hex nuts, (two per side), attaching the bumper assembly to the end of the frame, **(Figure 2)**. **WARNING!** Assistance is required to hold the bumper in place during bolt removal to prevent the bumper from falling. Remove the factory double bolt plates from the bumper brackets and carefully slide the bumper assembly with brackets off of the ends of the frame and tow hooks, if equipped, **(Figure 3)**.
4. Remove both tow hooks, (if equipped), from the ends of the frame, **(Figure 3)**.

**On models without tow hooks, skip to Step 10.**

5. Next, select (1) Single Bolt Plate and (1) Double Bolt Plate, **(Figure 4)**. Insert the Bolt Plates into the open end of the frame, with the long end on the plates in first toward the back. Select (1) Tow Hook Extension Bracket, **(Figure 5)**. Slide the Bracket over the bottom of the frame. Line up the slots in the Bracket with the factory tow hook mounting holes. Secure the Bracket to the Bolt Plates with (3) 12mm Flat Washers, (3) 12mm Lock Washers and (3) 12mm Hex Nuts, **(Figure 5)**. Leave loose at this time.
6. Select (1) tow hook. Place the tow hook on top of the Extension Bracket. Slide (1) Spacer Plate between each side of the tow hook and the Bracket, **(Figure 6)**. Reuse the factory hardware to attach the tow hook to the Extension Bracket, **(Figures 6 & 8)**. Push the tow hook, Spacers and Extension Bracket in and fully tighten tow hook and extension bracket hardware only. Do not fully tighten Frame Bracket hardware at this time.
7. Repeat **Steps 5 & 6** to install the passenger side Extension Bracket and tow hook if equipped.
8. Select the driver side Frame Mounting Bracket, **(Figure 7)**. Insert (2) 12mm x 140mm Hex Bolts with (2) 12mm Flat Washers through the slots in the side of the Bracket and into the frame. Slide (1) Spacer Plate between the inner side of the frame and the Bracket, **(Figures 7—9)**. Push the (2) Hex Bolts through the frame, the holes in the Spacer and out through the frame. Secure the Bracket to the Bolts with (2) 12mm Flat Washers, (2) 12mm Lock Washers and (2) 12mm Hex Nuts. Do not fully tighten hardware at this time.
9. Repeat **Step 8** to install the passenger side Frame Bracket.
10. With assistance, position the Bumper Assembly up to and over the Frame Brackets. Temporarily support the weight of the Bumper. **WARNING:** To avoid possible injury or damage to the vehicle, do not proceed until the Bumper is fully and safely supported.
11. Line up the (3) holes in the driver side mounting plate on the back of the Bumper with the (3) slots in the Frame Bracket. Attach the Bumper to the Bracket with the included (3) 10mm x 35mm Hex Bolts, (6) 10mm Flat Washers, (3) 10mm Lock Washers and (3) 10mm Hex Nuts, **(Figures 10 & 11)**. Do not fully tighten hardware at this time. Repeat this **Step** to attach the passenger side of the Bumper to the Frame Bracket.
12. Level and adjust the bumper and fully tighten all hardware.
13. If front license plate is required, attach the License Plate Bracket to the holes in the bumper with the included (2) 6mm x 20mm Button Head Screws, (4) 6mm Flat Washers and (2) 6mm Nylon Lock Nuts. Insert (2) Plastic Plugs into the square holes in the Bracket. Reuse the factory screws to attach the license plate to the plastic plugs, **(Figure 12)**.
14. **Center LED light installation** (sold separately).
  - a. Select the L/R “L” Brackets, **(Figure 13)**. Attach the Brackets to the top of the (2) mounting tabs welded onto the back of the bumper with the included 8mm x 25mm Hex Bolts, (4) 8mm Flat Washers, (2) 8mm Lock Washers and (2) 8mm Hex Nuts. Leave loose at this time.
  - b. Attach the LED light assembly to the “L” Brackets with the included (2) 8mm x 16mm Hex Bolts, (2) 8mm Lock Washers and (2) 8mm Flat Washers. Do not fully tighten hardware at this time.  
**IMPORTANT:** “L” Brackets are designed for 8mm light mounting hardware only. Modify “L” Brackets if necessary or use brackets supplied by your light manufacturer if possible to install hardware larger than 8mm.
  - c. Follow light manufacturer’s instructions to properly wire the light.
15. **LED light installation at ends of bumper** (sold separately).
  - a. Insert light into opening and up to mounting slots. Check for clearance between front and back of light. If necessary, remove the screen from the back of the opening, **(Figure 14)**.
  - b. Follow the light manufacturer’s instructions to attach (1) light to the center slot or (2) lights to the inner and outer slots in the top of the light opening. **IMPORTANT:** On two light systems with (1) flood and (1) spot light per side, attach the flood light to the outer and the spot light to the inner slot.
  - c. Repeat the above steps for passenger side light installation.
  - d. Follow light manufacturer’s instructions to properly wire the light.
16. Do periodic inspections to the installation to make sure that all hardware is secure and tight.

To protect your investment, wax this product after installing. Regular waxing is recommended to add a protective layer over the finish. Do not use any type of polish or wax that may contain abrasives that could damage the finish. Mild soap may be used to clean the Front Bumper assembly.

### Driver Side Installation Pictured

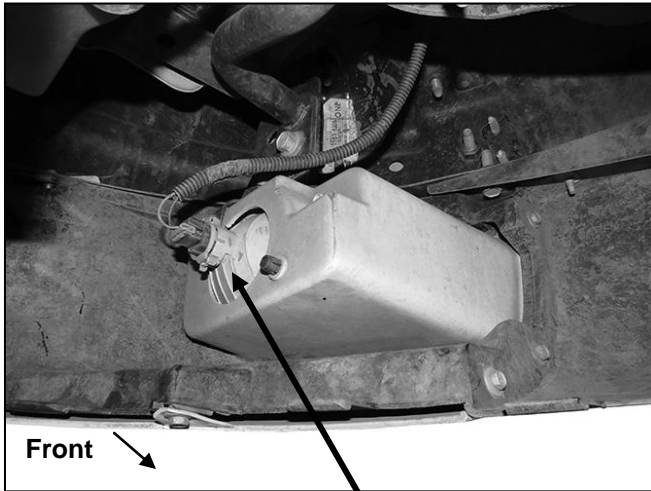

(Fig 1) Unplug fog lights and move wiring harness away from bumper before bumper removal

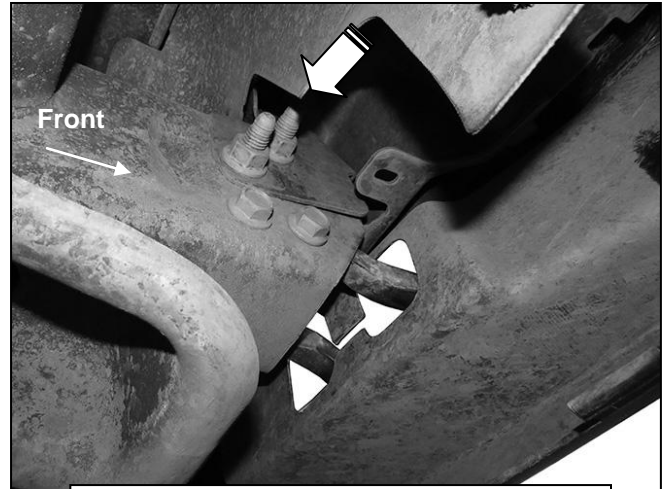

(Fig 2) From behind bumper, remove the hex nuts, (see arrow), attaching the bumper bracket to the double bolt plate

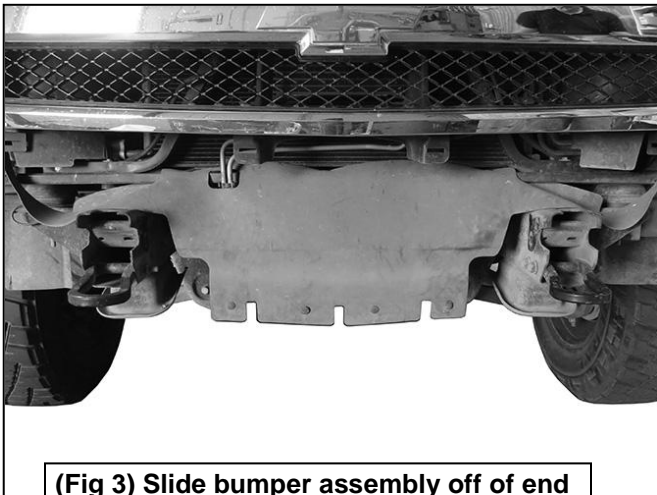

(Fig 3) Slide bumper assembly off of end of frame. Remove tow hooks if equipped

**WARNING!** Do not crawl under bumper unless the bumper is properly supported on blocks or stands or the bumper may fall.

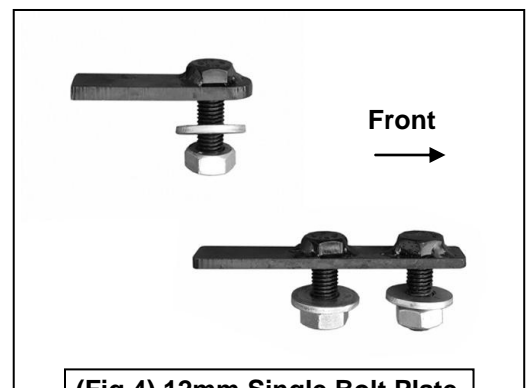

(Fig 4) 12mm Single Bolt Plate and 12mm Double Bolt Plate

### Driver Side Installation Pictured

**Double Bolt Plate**  
(2) 12mm Flat Washers  
(2) 12mm Lock Washers  
(2) 12mm Hex Nuts

**Single Bolt Plate**  
12mm Flat Washer  
12mm Lock Washer  
12mm Hex Nut

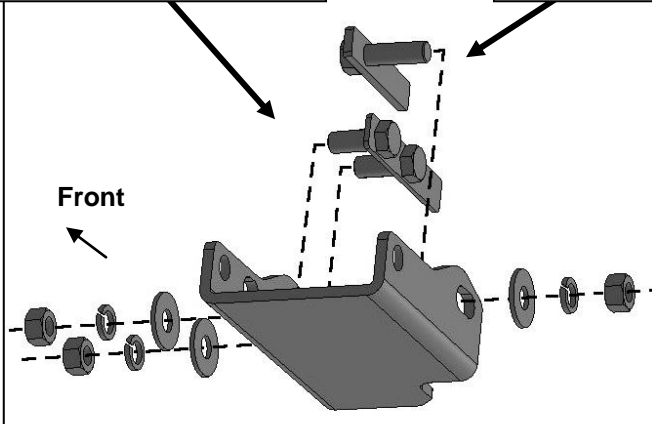

(Fig 5) Insert long end on Bolt Plates into open end of frame first then attach the Tow Hook Bracket (if equipped) to the frame and Bolt Plates

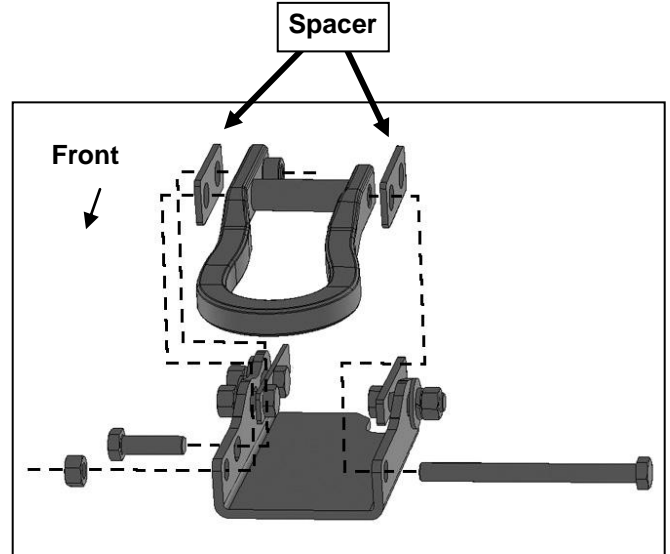

(Fig 6) Slide Spacer between each side of tow hook. Attach tow hook to Bracket with factory hardware.

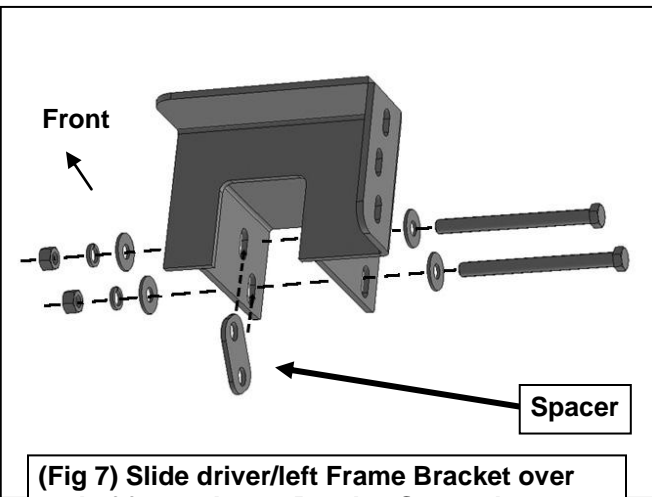

(Fig 7) Slide driver/left Frame Bracket over end of frame. Insert Bracket Spacer between Bracket and inner side of frame

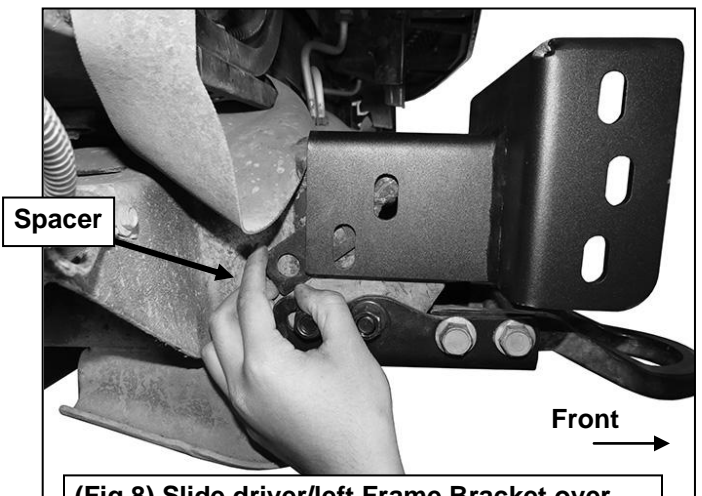

(Fig 8) Slide driver/left Frame Bracket over end of frame. Insert Bracket Spacer between Bracket and inner side of frame

Driver Side Installation Pictured

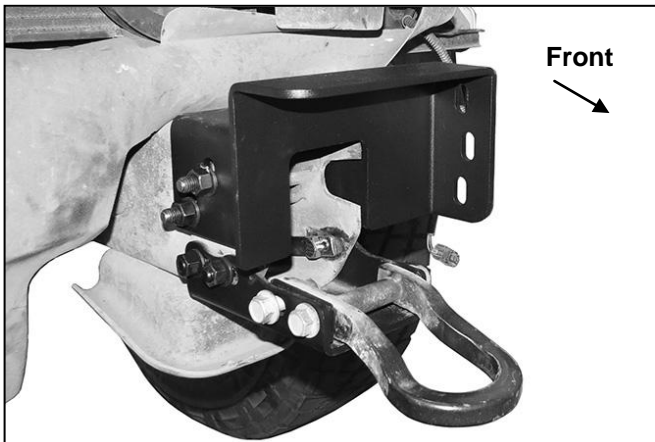

(Fig 9) Driver/left complete bracket installation

- (3) 10mm x 35mm Hex Bolts
- (6) 10mm Flat Washers
- (3) 10mm Lock Washers
- (3) 10mm Hex Nuts

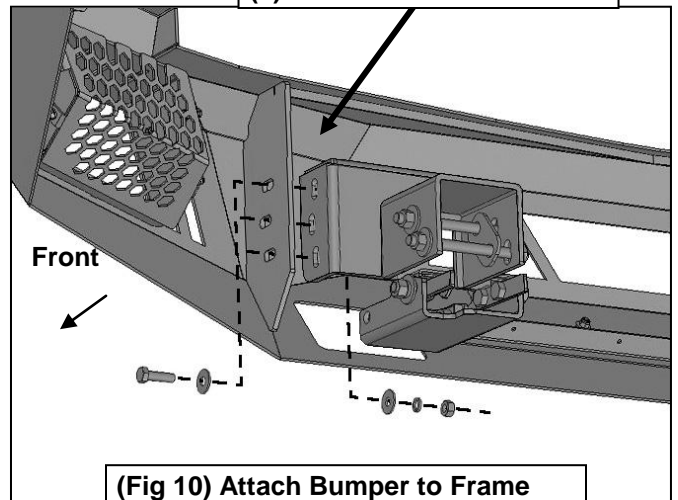

(Fig 10) Attach Bumper to Frame  
Brackets. Driver/left side illustrated

- (3) 10mm x 35mm Hex Bolts
- (6) 10mm Flat Washers
- (3) 10mm Lock Washers
- (3) 10mm Hex Nuts

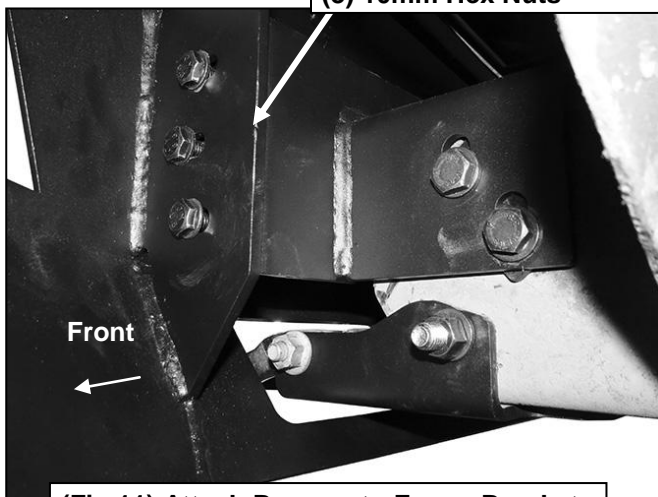

(Fig 11) Attach Bumper to Frame Brackets

**WARNING!** Do not crawl under bumper unless the bumper is properly supported on blocks or stands or the bumper may fall.

**Driver Side Installation Pictured**

