

**APPLICATIONS:**

2007-2013 CHEVY/GMC
SIERRA/SILVERADO
1500 SERIES FULL SIZE TRUCKS

Tools Required:

Torque Wrench
10mm socket
3/8" drive ratchet
3" 3/8" drive extension

Torque Table:

8mm Hardware torque to 25Nm (18lbf)

Parts List

Item	Description	Quantity		
		Regular	Extended	Crew
1	Tube Assembly Driver Side	1	1	1
2	Tube Assembly Passenger Side	1	1	1
3	M8 X 30 mm Bolt	8	12	16
4	M8 U-Nut	8	12	12

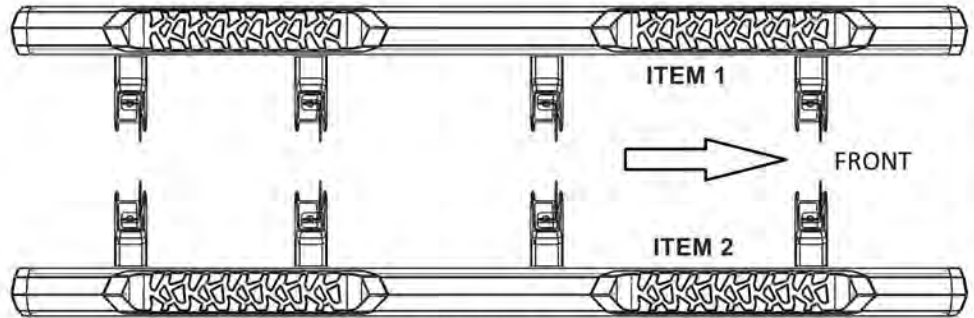

CREW CAB IS SHOWN. EXTENDED AND
REGULAR ARE SIMILAR.

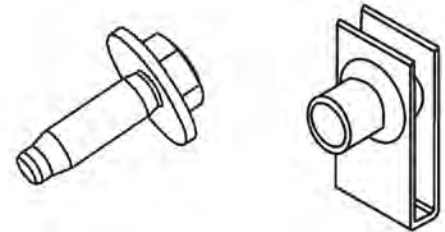

ITEM 3

ITEM 4

Tubular Assist Step Installation Procedure

1. Determine left hand and right hand tubular assist step by identification labels on bottom of steps.
2. Install U-nuts (Item 4) onto existing holes in pinch flange and inner rocker panel. See figure 1 and figure 2 for locations and orientation of U-nuts (Item 4). Install U-nuts (Item 4) with threads up on pinch flange. Install U-nuts (Item 4) with threads inside of the inner rocker panel. Regular cab trucks will use 8 U-Nuts. Extended cab trucks will use 12 U-nuts. Depending on how many weld nuts are in the first two bracket locations, some crew cab trucks will use 12 U-nuts and others will use 8 U-nuts. On some vehicles it may be necessary to remove and discard hole plugs to install the U-nuts.

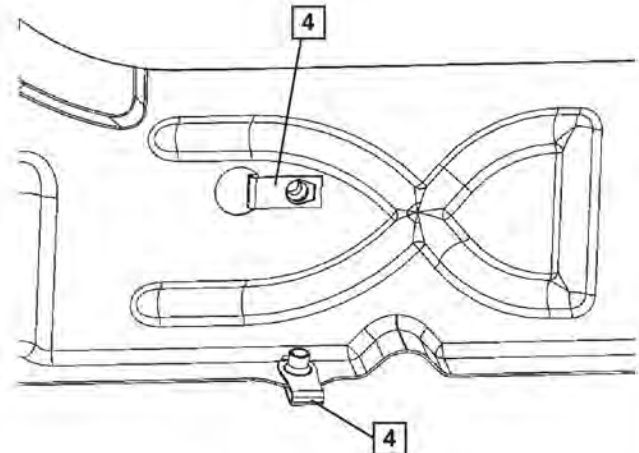
FIGURE 1

3. Install driver side tubular assist step (Item 1) by hanging front bracket in upper slot with loosely installed M8 bolt (Item 3). Then hang rear bracket in upper slot with loosely installed M8 bolt (Item 3). See Figure 2.

FIGURE 2

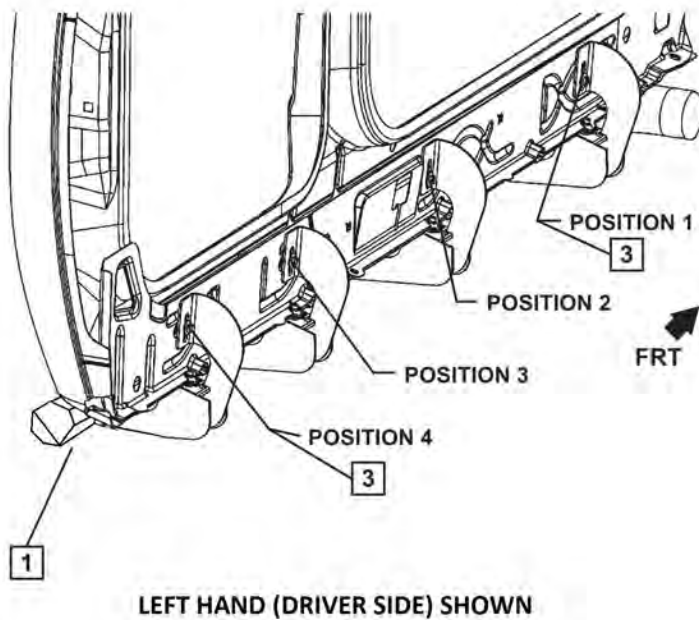

4. From underneath, loosely insert M8 X 30 mm bolts (Item 3) through bracket, bracket cover, rocker panel, and into U-nut (Item 4) in position 1. Repeat for position 4, then 2, 3. See Figure 3.
5. Loosely insert M8X30mm bolt (Item 3) through bracket and into U-nut (Item 4) in upper rocker panel position 2. Repeat for position 3.
6. Tighten the M8 bolts (Item 3) in lower positions to 25Nm in the following order position 1, position 4, position 2, and position 3.
7. Repeat step 6 for the upper positions. Tighten bolts to 25Nm.
8. Repeat steps 3 through 7 for passenger side tubular assist step assembly.
9. Verify correct torque on all hardware.

FIGURE 3

