

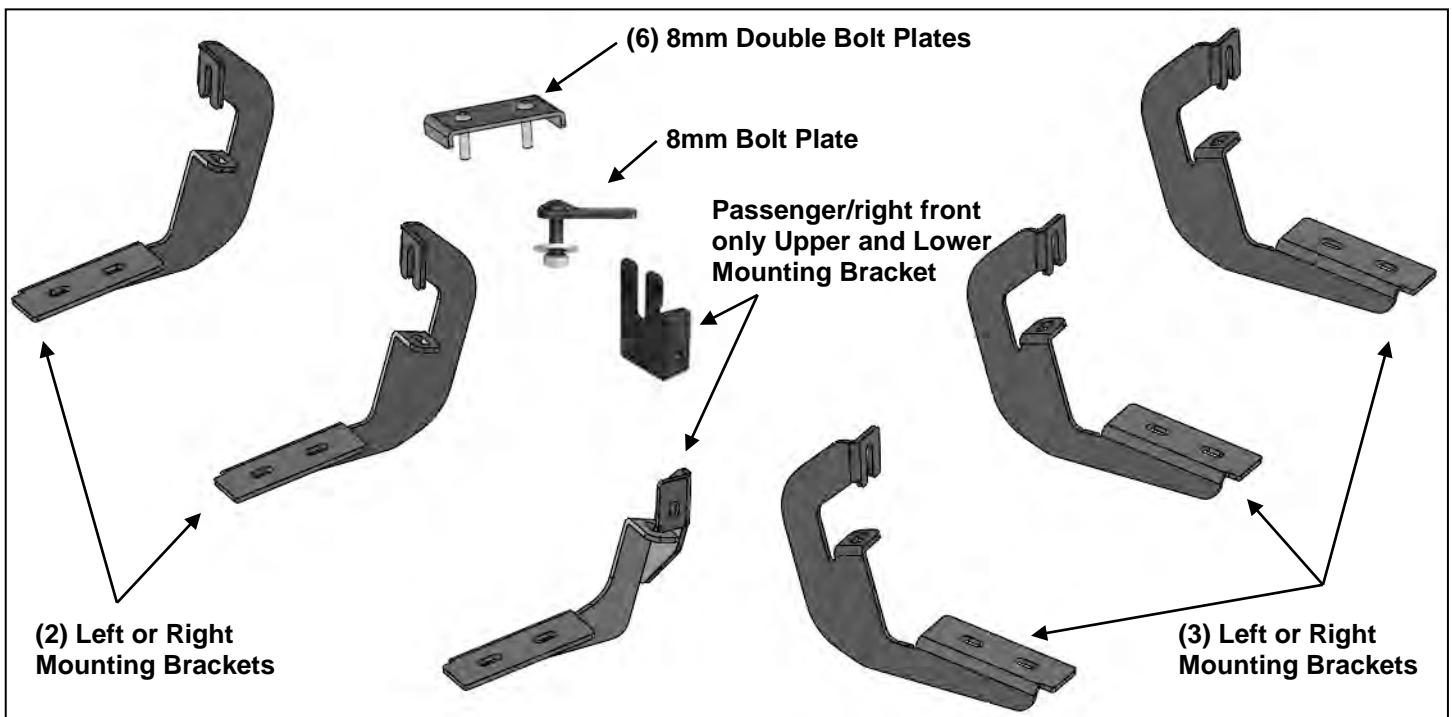

S6 RUNNING BOARDS 07-18 1500 SILVERADO/SIERRA EXTENDED/DOUBLE CAB

PARTS LIST:

1	79" Driver/left side Running Board	13	8-1.25mm x 25mm Hex Bolts
1	79" Passenger/right side Running Board	6	8mm x 35mm Double Bolt Plates
1	Passenger/right Front Upper Bracket (all incl. DEF)	25	8mm x 24mm x 2mm Flat Washers
1	Passenger/right Front Lower Bracket (all incl. DEF)	13	8mm Lock Washers
5	Mounting Brackets (use for left or right)	1	8-1.25mm Bolt Plate
11	8-1.25mm Clip-On Nuts	13	8mm Nylon Lock Nuts



PROCEDURE:

REMOVE CONTENTS FROM BOX. VERIFY ALL PARTS ARE PRESENT. READ INSTRUCTIONS CAREFULLY BEFORE STARTING INSTALLATION. ASSISTANCE IS RECOMMENDED. ON MODELS WITH DEF TANK, SELECT A FLAT, LEVEL AREA FOR INSTALLATION.

1. Start the installation under the driver side of the vehicle. Locate the 4 tabs along the bottom edge of the body, (pinch weld). Mounting Brackets will bolt to the 1st, 2nd and 4th mounting tabs, **(Figure 1)**. Directly above each tab is a top mounting location on the side of the body panel. Hold a Bracket up in place to help determine the mounting holes to use along the body.
2. Determine the correct procedure for your model year and each Bracket location.

Bottom mounting location on the edge of the pinch weld.

Flat tab on pinch weld with factory installed weld nut:

Thread hex bolt into weld nut from the backside-down to clear paint from threads, **(Figure 2)**.

Flat tab on pinch weld with hole:

Select (1) 8mm Clip Nut. Slide the Clip Nut over the tab with the nut facing up behind the tab, **(Figures 3 & 4)**. Line up threaded nut with hole in the tab. Repeat for each mounting location.

Locate top mounting location on the back side of the body panel.

Models with factory installed threaded insert in body panel:

Thread 8mm Hex Bolt into threaded insert to clear paint as required, (**Figures 2 & 3**).

Large and small hole in side of body panel:

Remove the rubber plug from the larger hole, (**Figure 4**). Select (1) 8mm Clip Nut. Slide the Clip Nut into the larger hole. Line up the threaded nut with the smaller hole, (**Figure 4**).

3. Select (1) Mounting Bracket. **NOTE:** (5) Brackets are universal and will fit all (3) left side locations and center and rear right side only. Bolt the Mounting Bracket to the Clip Nuts and/or the factory threaded holes with (2) 8mm Hex Bolts, (2) 8mm Lock Washers and (2) 8mm Flat Washers, (**Figures 5 & 6**). Snug but do not fully tighten the hardware.
4. Repeat **Steps 1—3** to install the (2) remaining driver side Brackets, (**Figures 5 & 6**).
5. Once all (3) Brackets have been fully installed, select the Driver/left side Running Board. **NOTE:** The front stepping pad is farther away from the front end of the Driver/left side Running Board. Select (3) 8mm Double Bolt Plates, (**Figure 7**). Insert the Bolt Plates into the channel on the bottom of the Running Board closest to the Brackets, (**Figure 8**).
6. With assistance, carefully position the Running Board onto the (3) Mounting Brackets. Attach the Running Board to the Mounting Brackets using (6) 8mm Flat Washers and (6) 8mm Nylon Lock Nuts, (**Figures 9 & 10**). Do not tighten hardware.
7. **NOTE:** The Running Board is designed to fit close to the vehicle. It may be necessary to loosen the Bracket hardware and tilt the Brackets downward to insert the Running Board between the Brackets and the body. Do not tighten hardware at this time.
8. Level and adjust the Running Board and fully tighten all hardware.
9. Move to the passenger side of the vehicle. On the passenger side, determine if the vehicle is equipped with a plastic diesel exhaust fluid (DEF) tank, (**Figures 11 & 12**).

Models without DEF tank, skip to Step 10.

Models with DEF tank: The tank sits close to the side of the body. With specialized tools, the passenger front upper and lower Bracket can be installed but room is very limited. Determine model year of vehicle before proceeding.

Up to 2016 models:

It may be easier to drop the tank down to access the inner side of the body panel for upper bracket installation. Tank will not need to be removed, only dropped down for access to mounting location.

IMPORTANT: If tank is full, it will be very heavy and assistance is highly recommended to avoid injury or damage to the vehicle or the tank. It is recommended that installation is performed when the DEF tank is low on fluid before dropping the tank.

- a. On models with plastic lower tray under the tank, remove the (3) hex bolts attaching the tray to the frame, (**Figure 11**), and remove the tray.
- b. Release the tank filler hose. Release the plug for the sending unit on the top of the tank.
- c. Support the tank with a floor jack. Place a smooth flat surface, (wooden block for example), between the floor jack and the tank to avoid damaging the plastic tank. Do not push up on the tank; only support the weight of the tank with the jack.
- d. Remove the (2) bolts securing the tank straps to the vehicle, (**Figure 12**). Tilt the straps to release from the brackets. Slowly lower the tank until the top of the tank is almost visible. Use blocks or stands to support the tank while installing the front Upper and Lower Brackets.
- e. Proceed to **Step 9**.

On 2017-on models:

- a. Remove the (4) hex bolts attaching plastic cover to DEF tank, (**Figure 13A**) and remove plastic cover, (**Figure 13B**). **NOTE:** On 2017-on 2500/3500 models, only remove plastic cover from DEF tank. Do not lower DEF tank. Proceed to **Step 10**.
10. Locate the first tab on the edge of the pinch weld, (**Figures 2—4, 15 & 17**). Select the Upper Bracket, (**Figure 14**). Repeat **Steps 2 & 3** to attach the passenger front Upper Bracket to the side of the body panel, (**Figure 15**). Do not tighten hardware at this time.
11. Line up the hole in the bottom of the Upper Bracket with the hole in the tab on the pinch weld.

- a. **Models with a weld-nut:** Slide the Bracket over the weld-nut, (**Figure 15**). Attach the Lower Bracket to the bottom of the body and weld-nut with (1) 8mm x 25mm Hex Bolt, (1) 8mm Lock Washer and (1) 8mm Flat Washer, (**Figures 18 & 23**). Leave loose at this time.
 - b. **Models with flat tab and hole:** Insert the 8mm Bolt Plate down through the hole in the Upper Bracket and mounting tab, (**Figures 16 & 17**). Attach the Lower Bracket to the bottom of the body and Bolt Plate with (1) 8mm Flat Washer and (1) 8mm Nylon Lock Nut, (**Figures 18 & 22**). Leave loose at this time.
12. Line up the side tab on the Lower Bracket with the threaded hole in the side of the Upper Bracket. Attach the Lower Bracket to the Upper Bracket with (1) 8mm x 25mm Hex Bolt, (1) 8mm Lock Washer and (1) 8mm Flat Washer, (**Figure 23**). Leave loose at this time.
 13. Repeat **Steps 1—3** for the (2) remaining passenger side Bracket installations. **NOTE:** Cradles on Brackets installed on passenger side will face forward.
 - a. **2017-on 2500/3500 DEF tank models:** Locate the 2nd tab bracket location along the bottom edge of the body, (pinch weld), (**Figure 19**). Hold the DEF cover in place and mark the 2nd Bracket location onto the cover, (**Figure 20**). Use a sharp knife or hacksaw blade to carefully cut a slot in the plastic cover to clear the 2nd Bracket, (**Figure 21**). Remove as little plastic as possible.
 14. Repeat **Steps 5—7** to install the passenger side Running Board.
 15. Once the Running Board has been installed and all hardware fully tightened, reinstall the DEF tank and cover, if equipped, as described in **Steps 8 & 12**.
 16. Do periodic inspections to the installation to make sure that all hardware is secure and tight.

To protect your investment, wax this product after installing. Regular waxing is recommended to add a protective layer over the finish. Do not use any type of polish or wax that may contain abrasives that could damage the finish. Aluminum polish may be used to polish small scratches and scuffs on the finish. Mild soap may be used also to clean the Running Board.

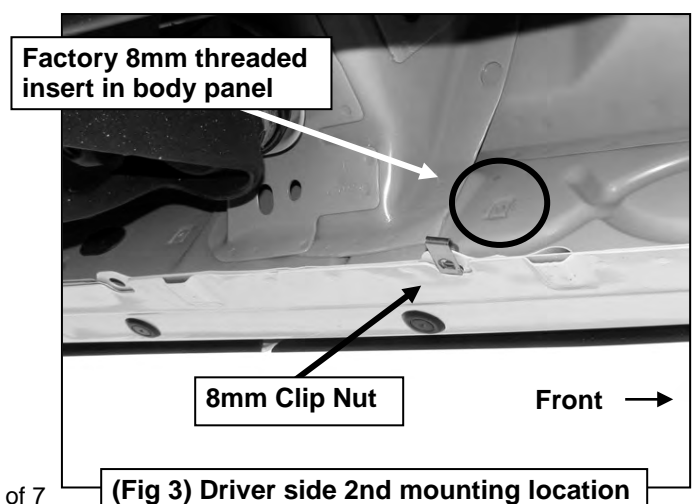
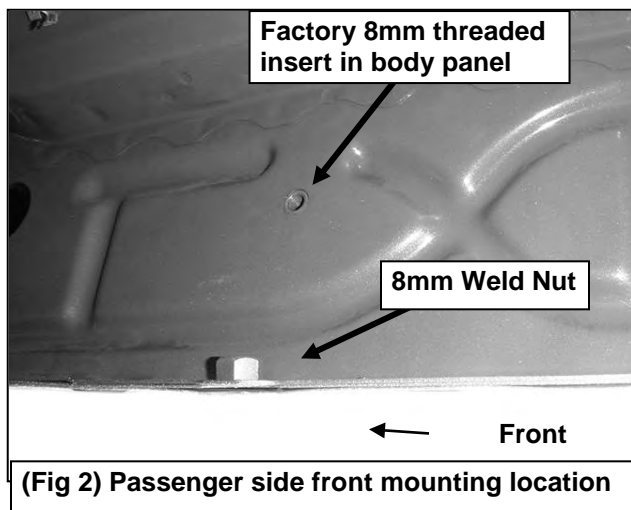
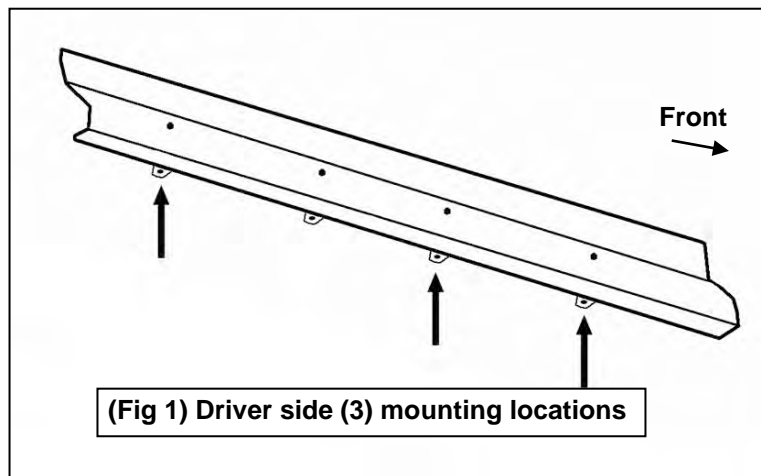

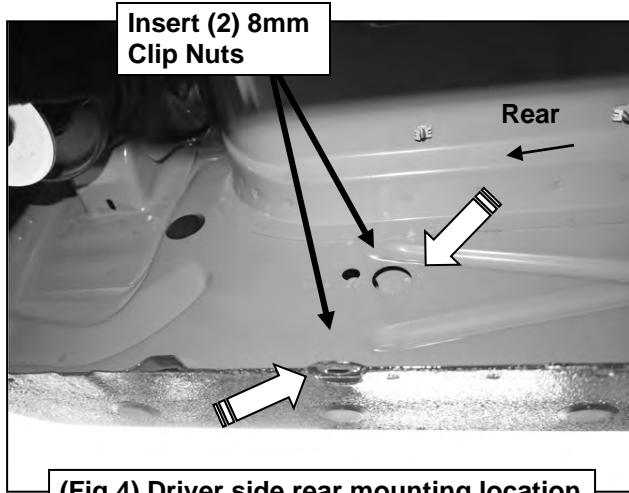

(Fig 4) Driver side rear mounting location

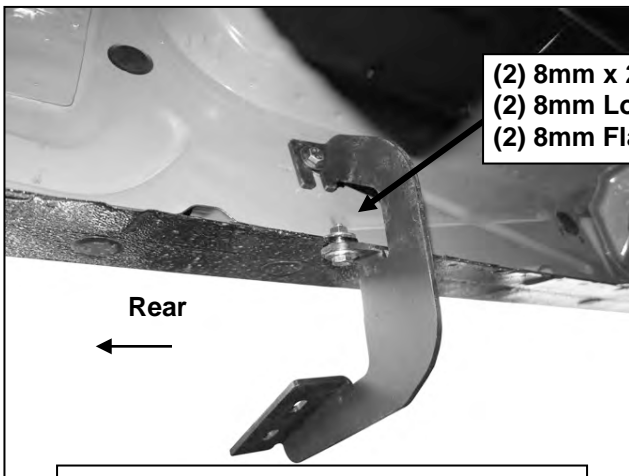

(Fig 6) Driver/left rear bracket installed

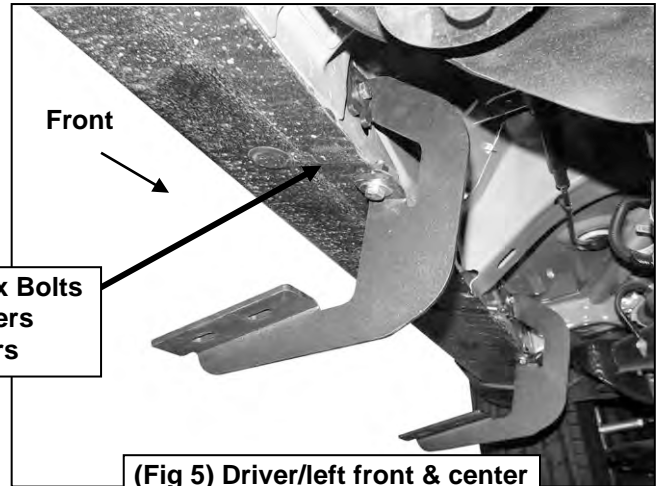

(Fig 5) Driver/left front & center
Mounting Brackets installed

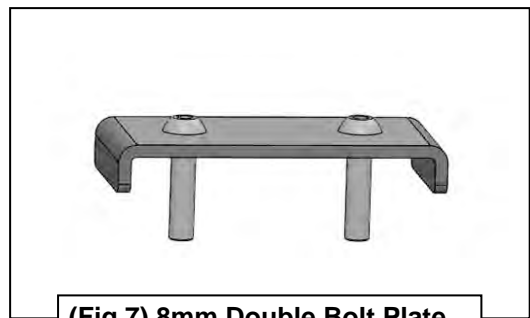
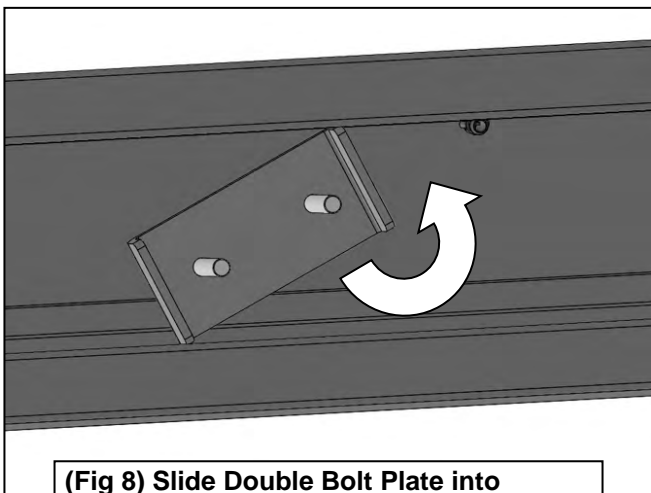

Driver/Left Side Installation Pictured

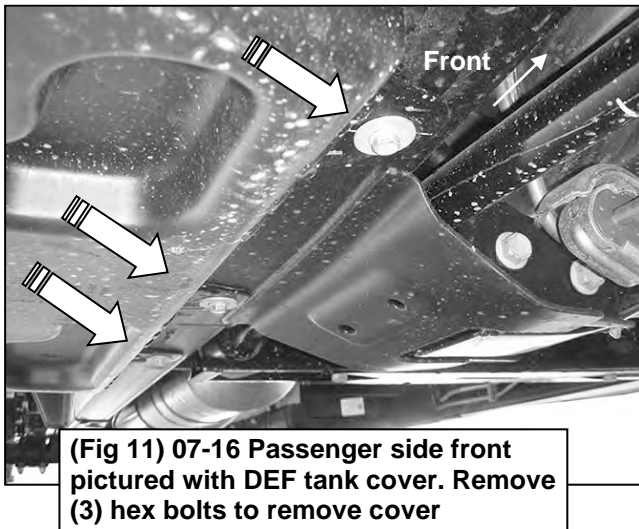
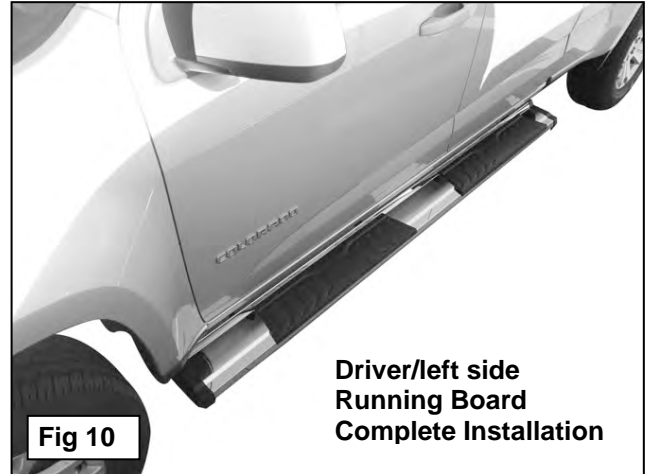
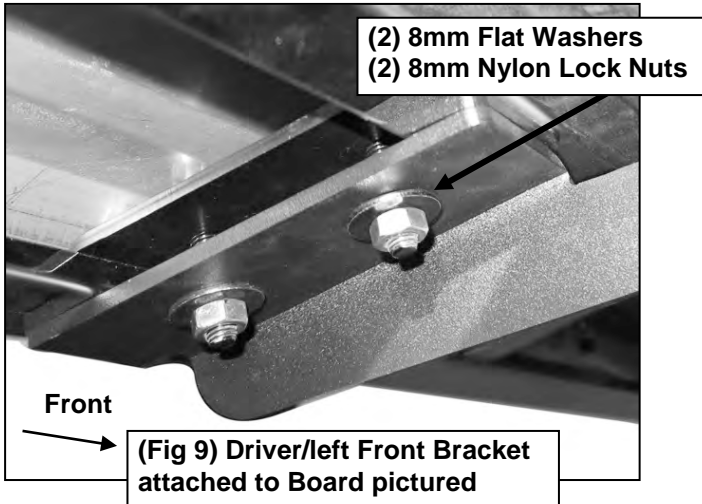

Remove (2) factory bolts to remove tank straps

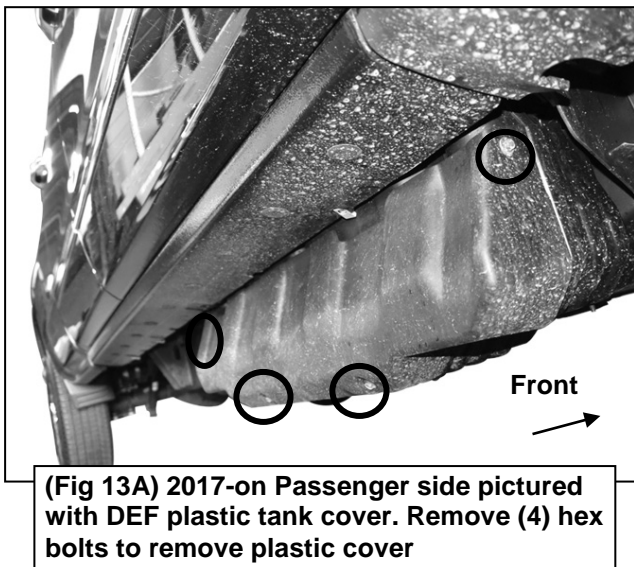
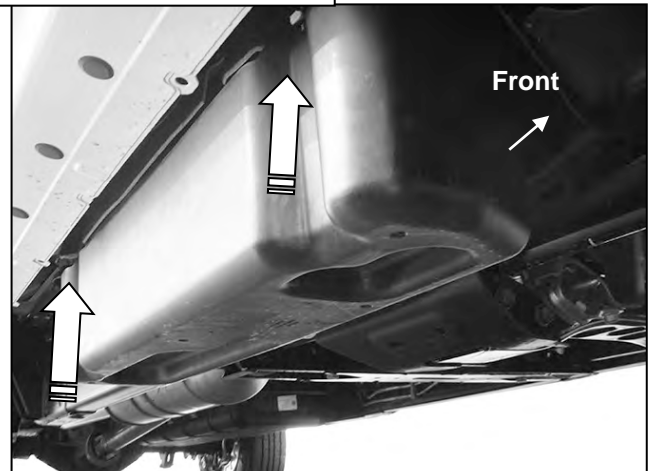

Passenger Side/Right Installation Pictured

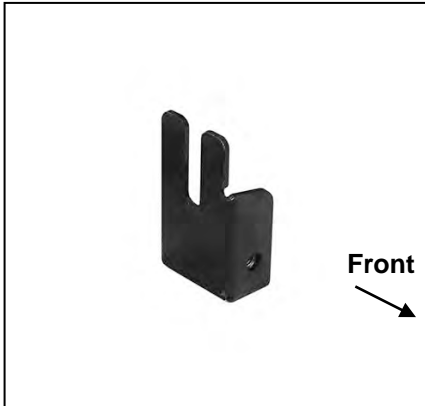

(Fig 14) Passenger/right Front Upper Bracket (all models)



(Fig 16) 8mm x 35mm Bolt Plate

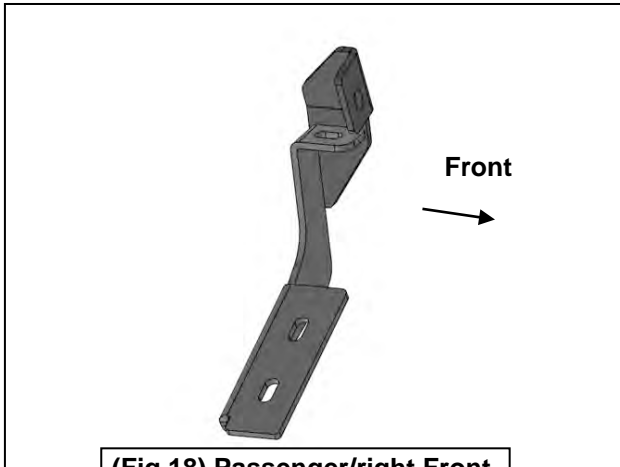

(Fig 18) Passenger/right Front Lower Bracket (all models)

8mm x 25mm Hex Bolt
8mm Lock Washer
8mm Flat Washer

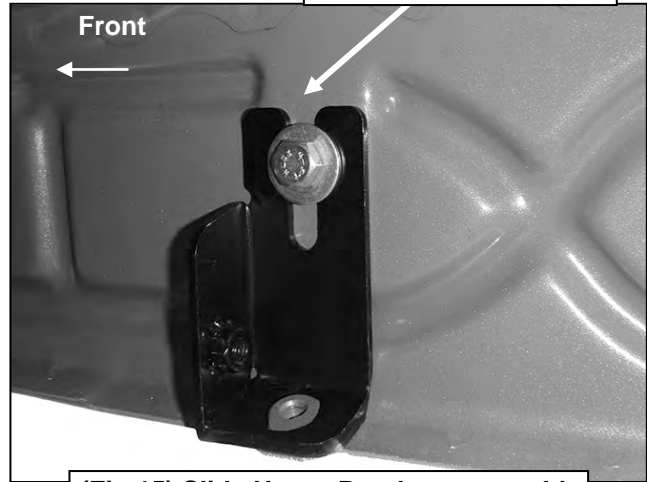

(Fig 15) Slide Upper Bracket over weld nut if equipped-also see Figure 2

On models with flat tab (see Fig 3 & 4),
insert 8mm Bolt Plate (Fig 16) down
through Upper Bracket and mounting tab

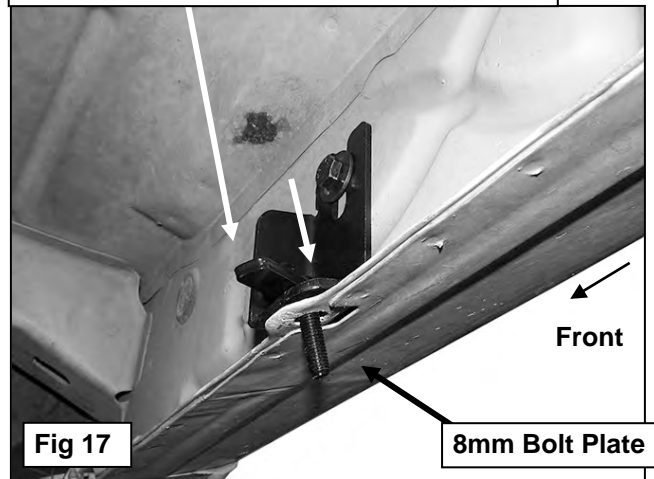

Passenger Side/Right Installation Pictured

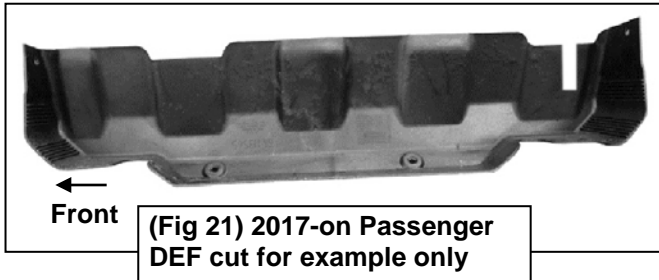
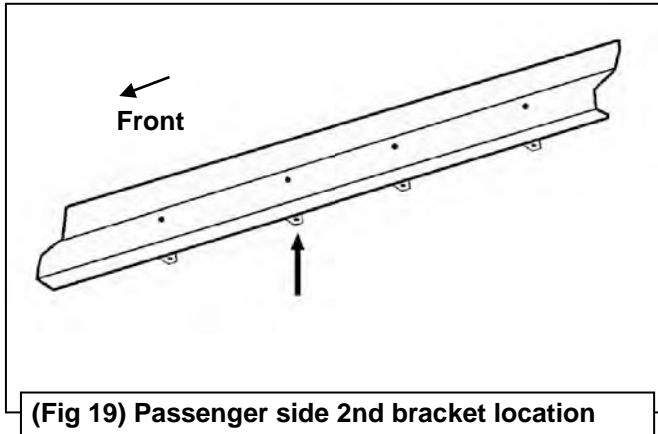

On models with flat tab and 8mm Bolt Plate (see Fig. 17) use:
 8mm Flat Washer
 8mm Nylon Lock Nut
 to attach Lower Bracket to Bolt Plate

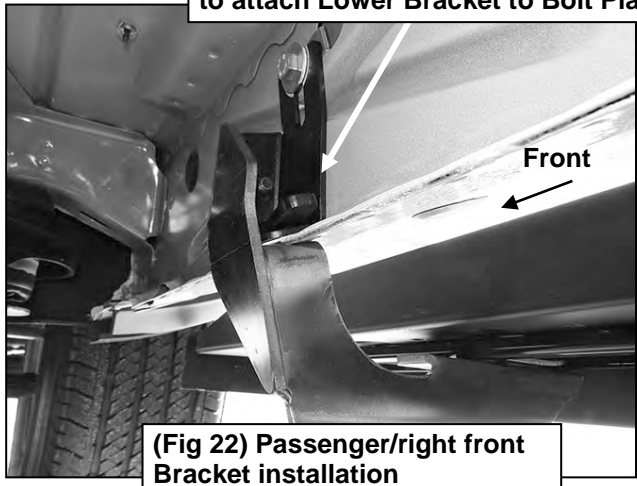

All models use:
 8mm x 25mm Hex Bolt
 8mm Lock Washer
 8mm Flat Washer

Models with weld nut on tab (see Fig. 15) use:
 8mm x 25mm Hex Bolt
 8mm Lock Washer
 8mm Flat Washer



(2) 8mm Flat Washers
 (2) 8mm Nylon Lock Nuts