

PARTS LIST: S112213

1	Driver/left side Running Board	1	8mm x 40mm Hex Bolt
1	Passenger/right side Running Board	1	8mm x 35mm Bolt Plate
4	Driver/left side Mounting Brackets	15	8mm x 25mm Hex Bolts
3	Passenger/right side Mounting Brackets	15	8mm Clip-on Nuts
1	Passenger/right side Front Mounting Bracket	1	8mm x 28mm x 3mm Flat Washer
1	Passenger/right side Front Upper Bracket	16	8mm x 24mm x 2mm Flat Washers
16	10mm x 35mm Hex Bolts	15	8mm Lock Washers
32	10mm x 27mm x 3mm Flat Washers	1	8mm Nylon Lock Nut
16	10mm Nylon Lock Nuts		

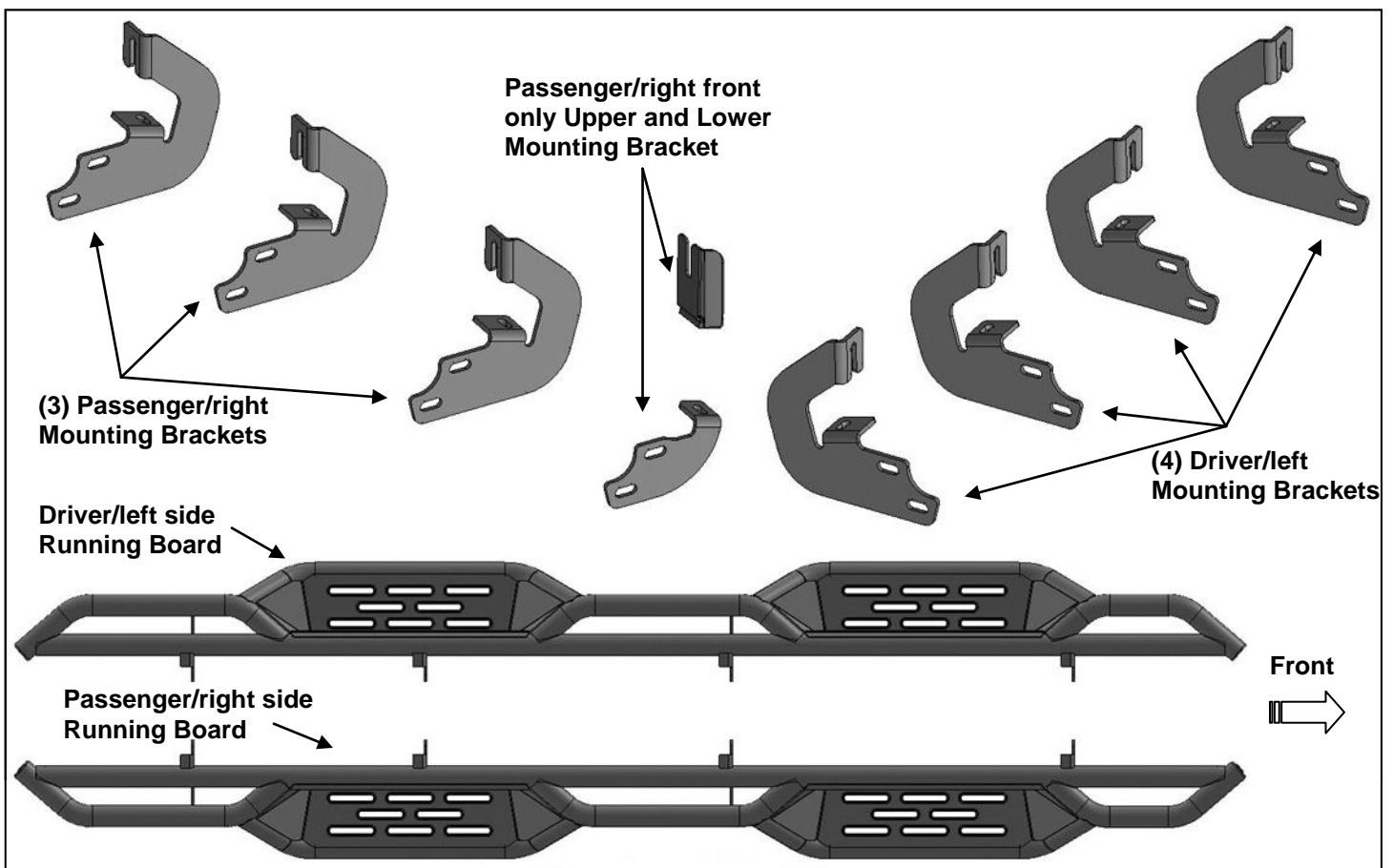

PROCEDURE:

REMOVE CONTENTS FROM BOX. VERIFY ALL PARTS ARE PRESENT. READ INSTRUCTIONS CAREFULLY BEFORE STARTING INSTALLATION. ASSISTANCE IS RECOMMENDED. ON MODELS WITH DEF TANK, SELECT A FLAT, LEVEL AREA FOR INSTALLATION. MAY REQUIRE CUTTING.

1. Start the installation under the driver side of the vehicle. Locate the 5 tabs along the bottom edge of the body, (pinch weld). Mounting Brackets will bolt to the 1st, 2nd, 4th and 5th mounting tabs, **(Figure 1)**. Directly above each tab is a top mounting location on the side of the body panel. Hold a Bracket up in place to help determine the mounting holes to use along the body.
2. Determine the correct procedure for your model year and each Bracket location. **Locate bottom mounting location on the edge of the pinch weld.**

Flat tab on pinch weld with factory installed weld nut:

Thread hex bolt into weld nut from the backside-down to clear paint from threads, **(Figure 2)**.

Flat tab on pinch weld with hole:

Select (1) 8mm Clip Nut. Slide the Clip Nut over the tab with the nut facing up behind the tab, **(Figures 3—6)**. Line up threaded nut with hole in the tab. Repeat for each mounting location.

Locate top mounting location on the back side of the body panel.

Models with factory installed threaded insert in body panel:

Thread 8mm Hex Bolt into threaded insert to clear paint as required, **(Figures 2 & 3)**.

Large and small hole in side of body panel:

Remove the rubber plug from the larger hole, **(Figures 4 & 5)**. Select (1) 8mm Clip Nut. Slide the Clip Nut into the larger hole. Line up the threaded nut with the smaller hole, **(Figure 6)**.

3. Select (1) driver/left side Mounting Bracket. **NOTE:** There are (4) Driver side Mounting Brackets, use the illustration above to determine the correct Bracket. Bolt the Mounting Bracket to the Clip Nuts and/or the factory threaded holes with (2) 8mm x 25mm Hex Bolts, (2) 8mm Lock Washers and (2) 8mm x 24mm Flat Washers, **(Figure 7)**. Do not tighten hardware.
4. Repeat **Steps 1—3** to install the (3) remaining driver side Mounting Brackets, **(Figure 8)**.
5. Select the driver/left side Running Board. **NOTE:** Use the illustration on **Page 1** to properly identify the driver side Running Board. With assistance, attach the Running Board to the rear facing side of the Brackets with (8) 10mm Hex Bolts, (16) 10mm Flat Washers and (8) 10mm Nylon Lock Nuts, **(Figures 9 & 10)**. Do not tighten hardware at this time.
6. Level and adjust the Running Board and fully tighten all hardware.
7. Move to the passenger side of the vehicle. On the passenger side, determine if the vehicle is equipped with a plastic diesel exhaust fluid (DEF) tank, **(Figures 11 & 13)**.

Models without DEF tank, skip to Step 8.

Models with DEF tank: The tank sits close to the side of the body. With specialized tools, the passenger front upper and lower Bracket can be installed but room is very limited. Determine model year of vehicle before proceeding.

Up to 2016 models:

It may be easier to drop the tank down to access the inner side of the body panel for upper bracket installation. Tank will not need to be removed, only dropped down for access to mounting location.

IMPORTANT: If tank is full, it will be very heavy and assistance is highly recommended to avoid injury or damage to the vehicle or the tank. It is recommended that installation is performed when the DEF tank is low on fluid before dropping the tank.

- a. On models with plastic lower tray under the tank, remove the (3) hex bolts attaching the tray to the frame, **(Figure 11)**, and remove the tray.
- b. Release the tank filler hose. Release the plug for the sending unit on the top of the tank.
- c. Support the tank with a floor jack. Place a smooth flat surface, (wooden block for example), between the floor jack and the tank to avoid damaging the plastic tank. Do not push up on the tank; only support the weight of the tank with the jack.
- d. Remove the (2) bolts securing the tank straps to the vehicle, **(Figure 12)**. Tilt the straps to release from the brackets. Slowly lower the tank until the top of the tank is almost visible. Use blocks or stands to support the tank while installing the front Upper and Lower Brackets.
- e. Proceed to **Step 8**.

On 2017 models:

- a. Remove the (4) hex bolts attaching plastic cover to DEF tank, **(Figure 13A)** and remove plastic cover, **(Figure 13B)**. **NOTE:** On 2017 2500/3500 models, only remove plastic cover from DEF tank. Do not lower DEF tank and proceed to **Step 8**.
8. Locate the first tab on the edge of the pinch weld, **(Figures 2—5, 15 & 17)**. Select the Upper Bracket, **(Figure 14)**. Repeat **Steps 2 & 3** to attach the passenger front Upper Bracket to the side of the body panel, **(Figure 15)**. Do not tighten hardware at this time.
9. Line up the hole in the bottom of the Upper Bracket with the hole in the tab on the pinch weld.

- a. **Models with a weld-nut:** Slide the Bracket over the weld-nut, **(Figure 15)**. Attach the Lower Bracket to the bottom of the body and weld-nut with (1) 8mm x 40mm Hex Bolt, (1) 8mm x 24mm Flat Washer, (1) 8mm x 28mm Flat Washer and (1) 8mm Nylon Lock Nut, **(Figures 15, 18 & 22)**. Leave loose at this time.
 - b. **Models with flat tab and hole:** Insert the 8mm Bolt Plate down through the hole in the Upper Bracket and mounting tab, **(Figures 16 & 17)**. Attach the Lower Bracket to the bottom of the body and Bolt Plate with (1) 8mm x 24mm Flat Washer and (1) 8mm Nylon Lock Nut, **(Figures 18 & 22)**. Leave loose at this time.
10. Repeat **Steps 1—3** for the (3) remaining passenger side Bracket installations.
- a. **2017 2500/3500 DEF tank models:** Locate the 2nd tab bracket location along the bottom edge of the body, (pinch weld), **(Figure 19)**. Hold the DEF cover in place and mark the location onto the cover, **(Figure 20)**. Use a sharp knife or hacksaw blade to carefully cut a slot in the plastic cover to clear the 2nd Bracket, **(Figure 21)**. Remove as little plastic as possible.
11. Repeat **Steps 5 & 6** to install the passenger side Running Board, **(Figure 23)**.
12. Once the Running Board has been installed and all hardware fully tightened, reinstall the DEF tank and cover, if equipped, as described in **Steps 7 & 10**.
13. Do periodic inspections to the installation to make sure that all hardware is secure and tight.

To protect your investment, wax this product after installing. Regular waxing is recommended to add a protective layer over the finish. Do not use any type of polish or wax that may contain abrasives that could damage the finish. Aluminum polish may be used to polish small scratches and scuffs on the finish. Mild soap may be used to clean Running Boards.

Driver/Left side Installation Pictured

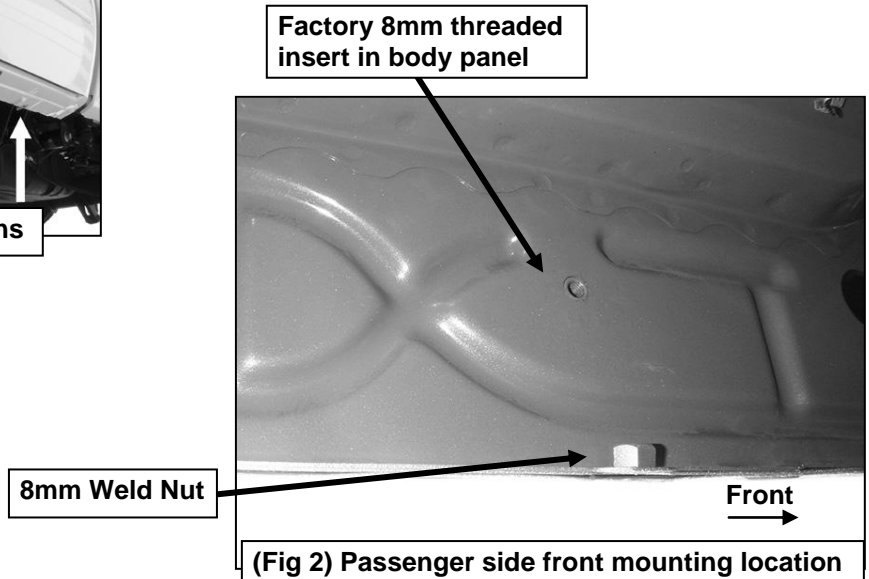
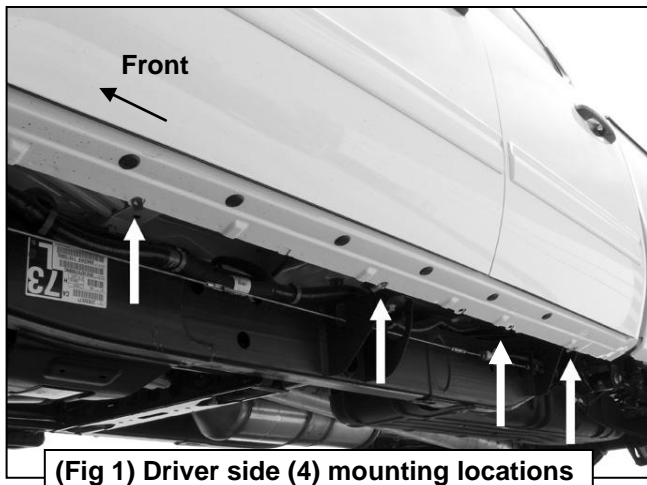

Driver/Left side Installation Pictured

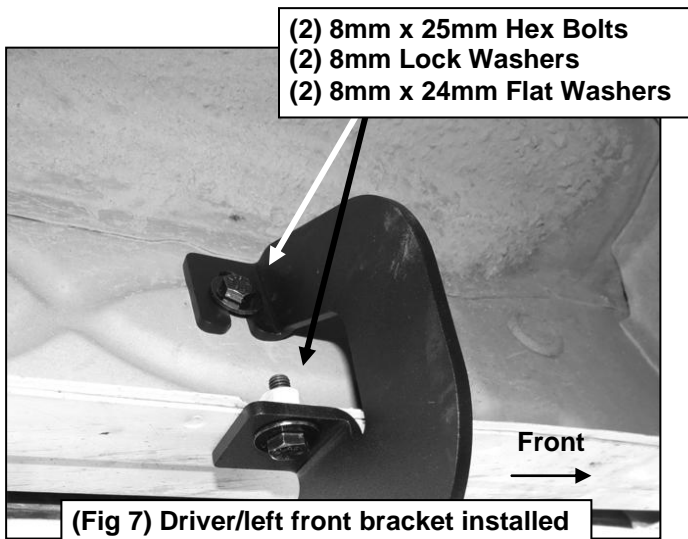
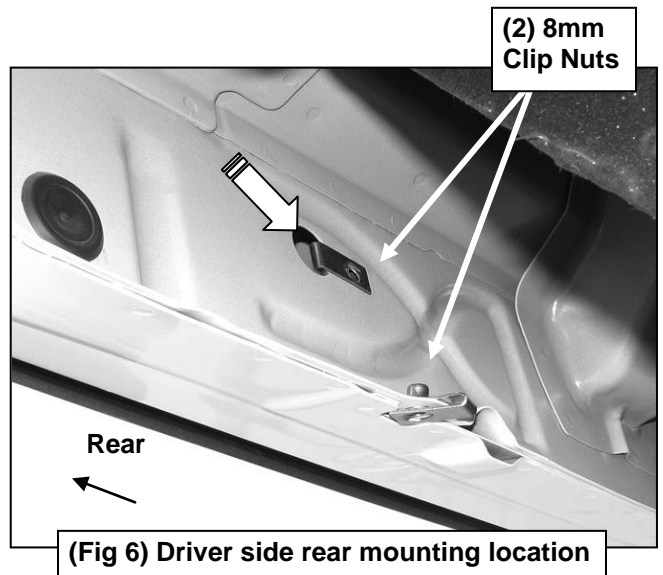
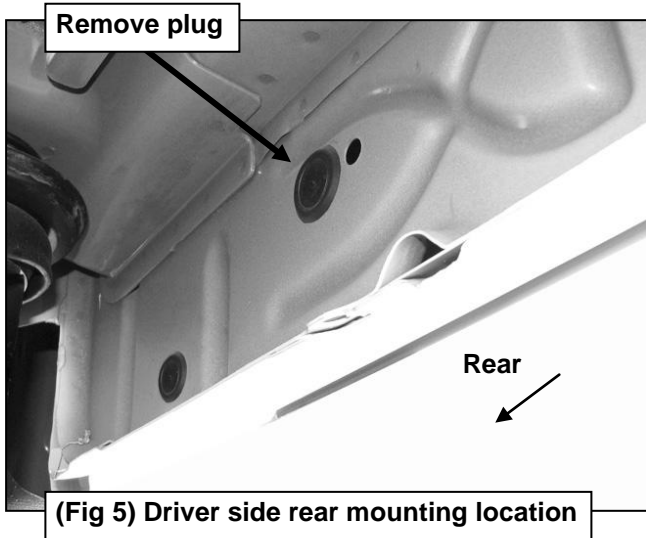
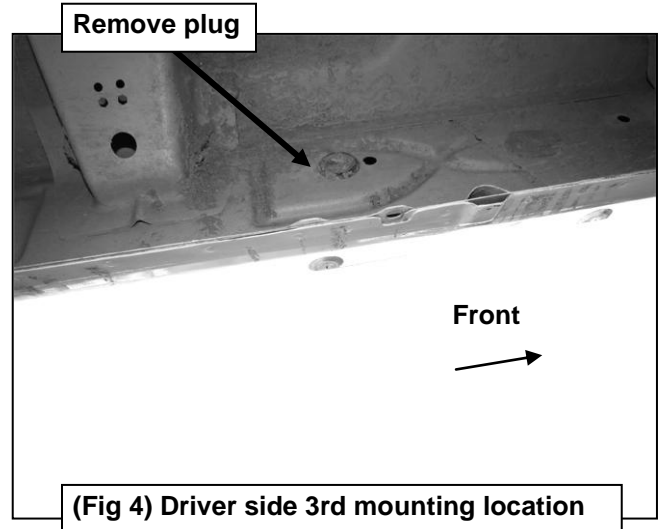
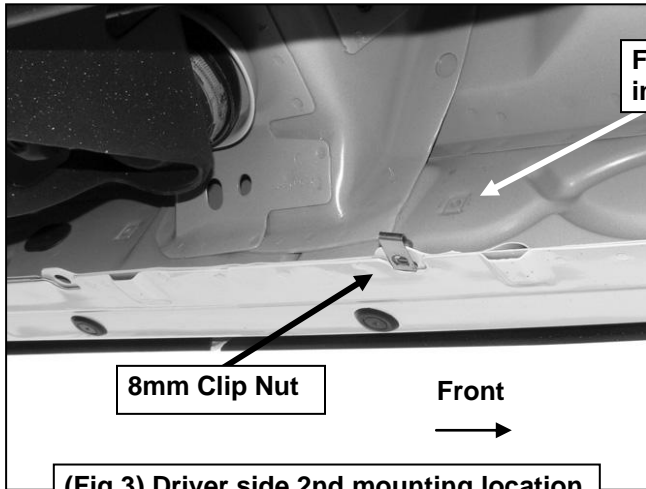

Driver/Left side Installation Pictured

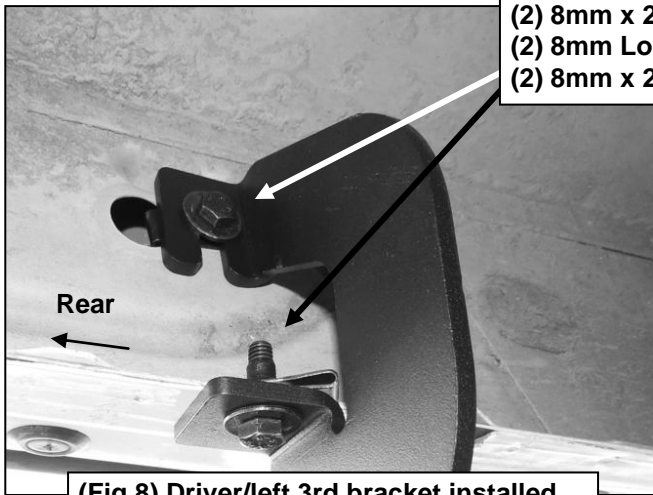

- (2) 8mm x 25mm Hex Bolts
- (2) 8mm Lock Washers
- (2) 8mm x 24mm Flat Washers

(Fig 8) Driver/left 3rd bracket installed

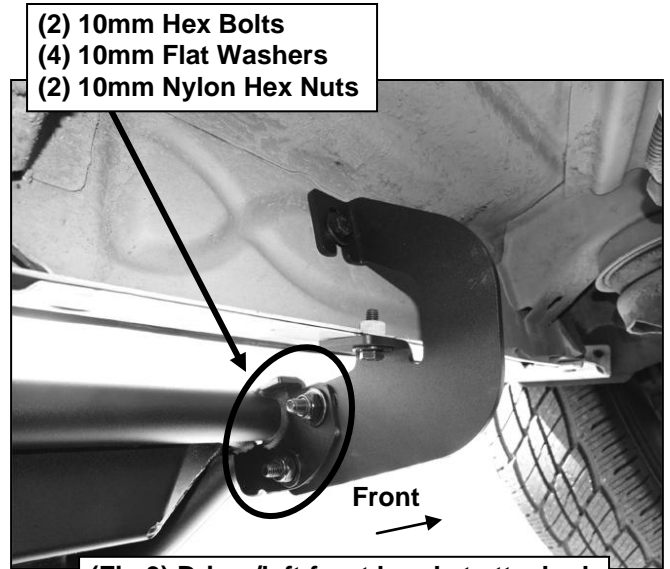

- (2) 10mm Hex Bolts
- (4) 10mm Flat Washers
- (2) 10mm Nylon Hex Nuts

(Fig 9) Driver/left front bracket attached to driver side Running Board

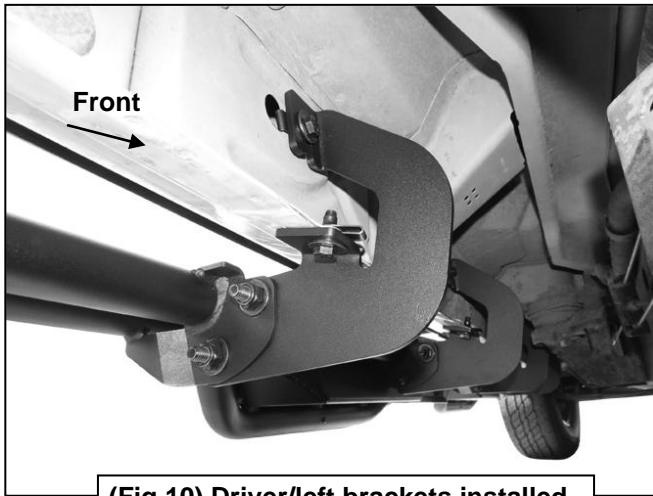

(Fig 10) Driver/left brackets installed

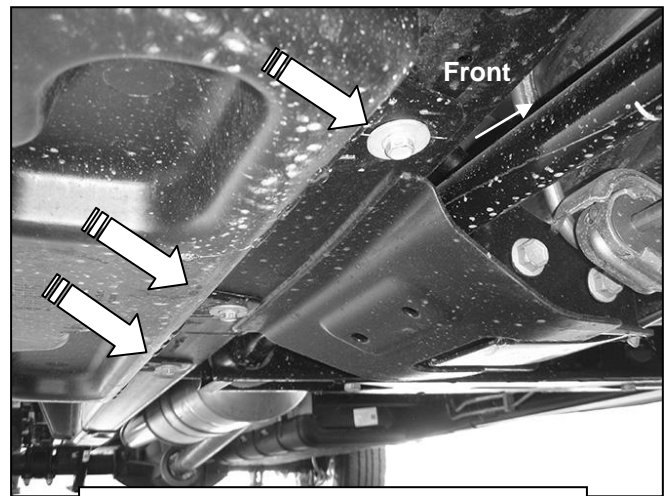

(Fig 11) 07-16 Passenger side front pictured with DEF tank cover. Remove (3) hex bolts to remove cover

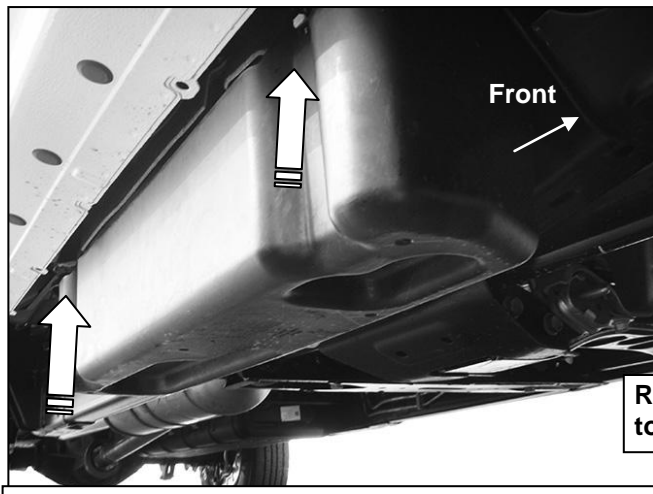

Remove (2) factory bolts to remove tank straps

(Fig 12) 07-16 Passenger side DEF tank and cover

Passenger/Right side Installation Pictured

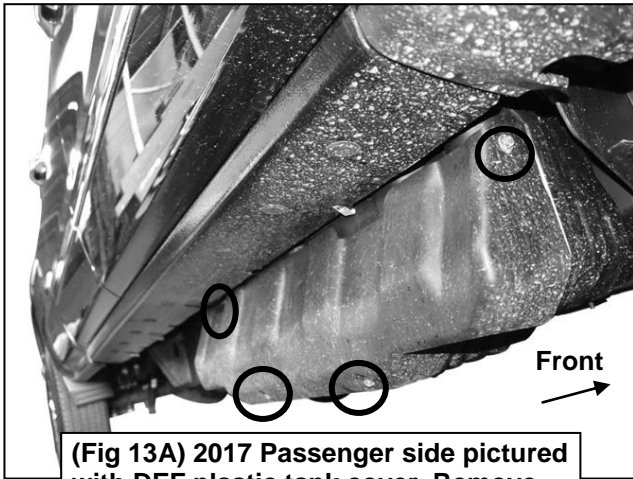

(Fig 13A) 2017 Passenger side pictured with DEF plastic tank cover. Remove (4) hex bolts to remove plastic cover



(Fig 13B) 2017 Passenger side DEF cover

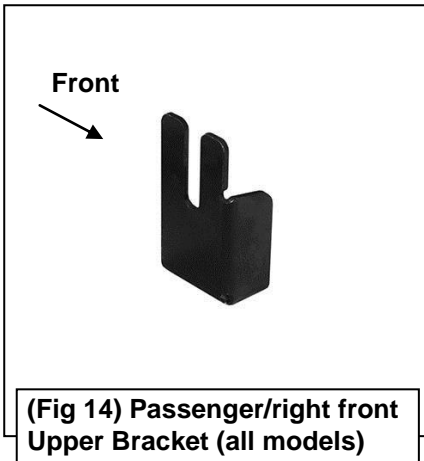

(Fig 14) Passenger/right front Upper Bracket (all models)

Models with weld nut on tab use:
8mm x 40mm Hex Bolt
8mm x 24mm Flat Washer
8mm x 28mm Flat Washer
8mm Nylon Lock Nut
to bolt Lower Bracket to weld nut

8mm x 25mm Hex Bolt
8mm Lock Washer
8mm x 24mm Flat Washer

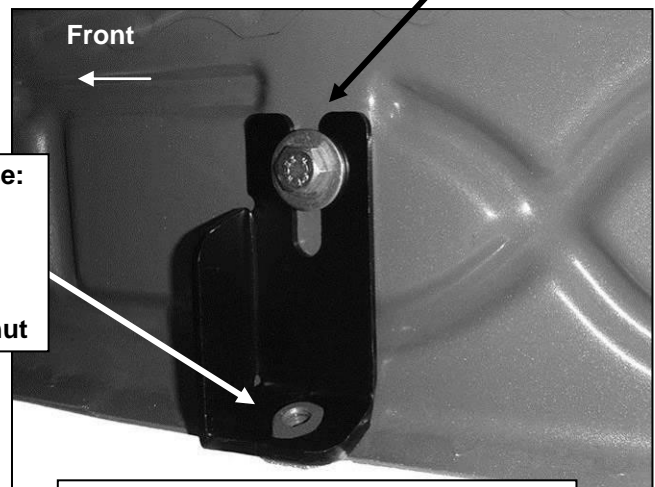

(Fig 15) Slide Upper Bracket over weld nut if equipped-also see Figure 2



(Fig 16) 8mm x 35mm Bolt Plate

Passenger/Right side Installation Pictured

On models with flat tab (see Fig 3 & 4),
insert 8mm Bolt Plate (Fig 16) down
through Upper Bracket and mounting tab

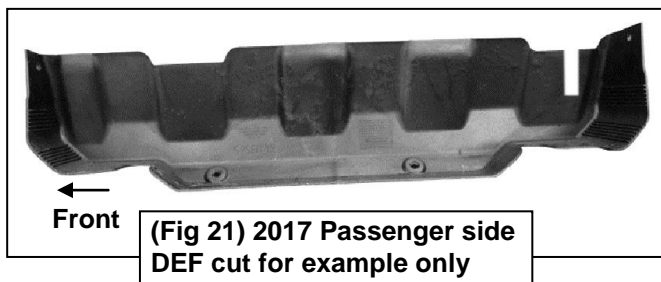
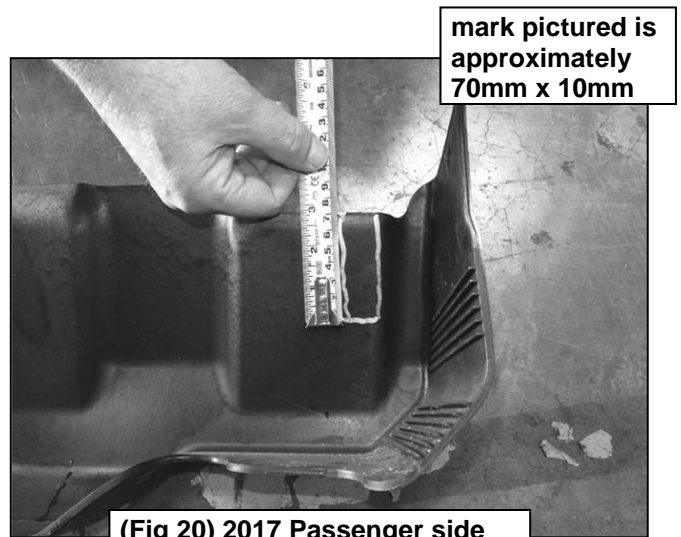
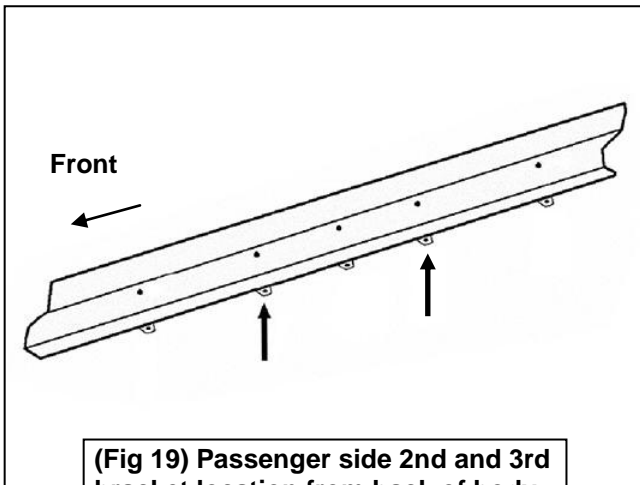
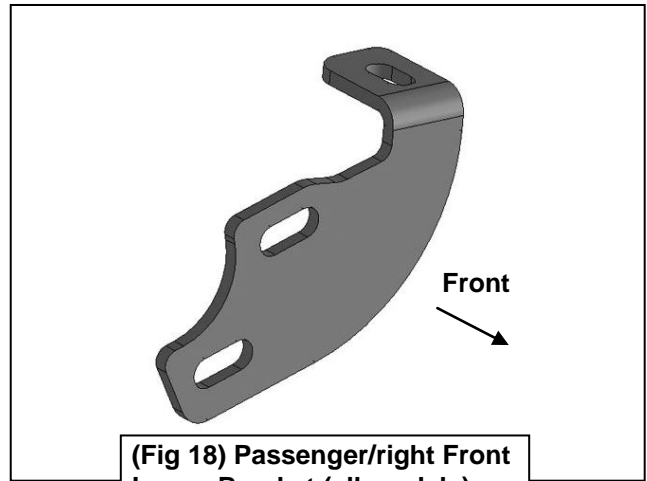
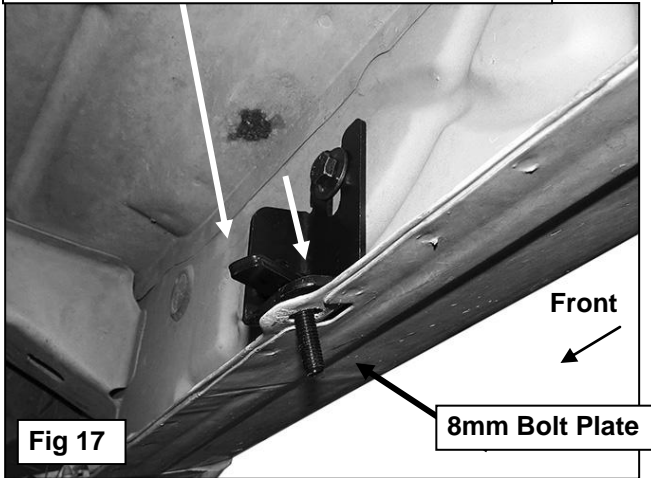

Passenger/Right side Installation Pictured

On models with flat tab and 8mm Bolt Plate (see Fig. 17) use:
8mm x 24mm Flat Washer
8mm Nylon Lock Nut
to attach Lower Bracket to Bolt Plate

Models with weld nut on tab use:
8mm x 40mm Hex Bolt
8mm x 24mm Flat Washer
8mm x 28mm Flat Washer
8mm Nylon Lock Nut
to bolt Lower Bracket to weld nut

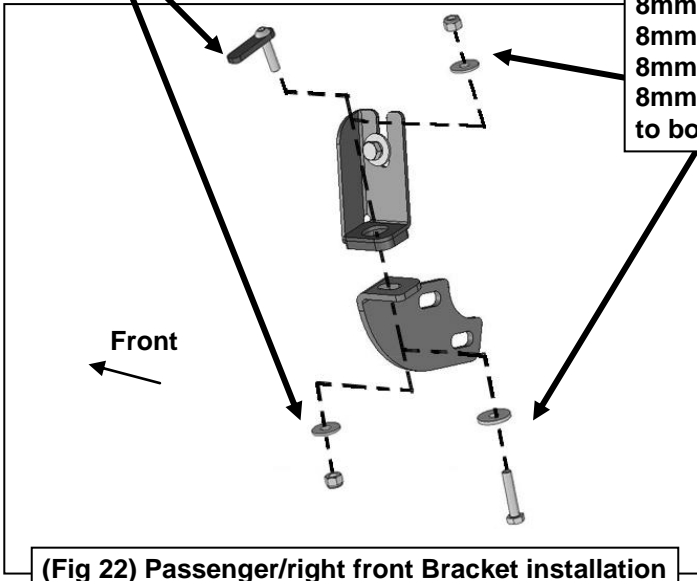

All models use:
8mm x 25mm Hex Bolt
8mm Lock Washer
8mm x 24mm Flat Washer

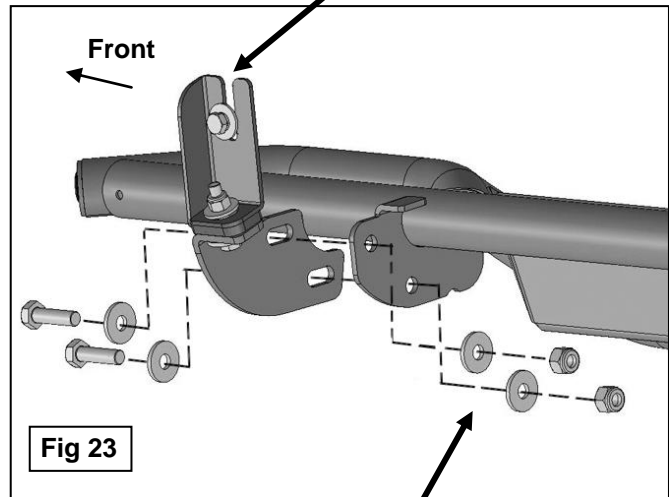

(2) 10mm Hex Bolts
(4) 10mm Flat Washers
(2) 10mm Nylon Lock Nuts

