

HD Rear Bumper Installation Guide

**PART NUMBER S112236/S509783
FITS Chevy Silverado / GMC Sierra
1500 07-13**

KEY TO COMPONENTS

- A. 1 ea. Rear bumper
- B. 1 ea. Driver side mounting bracket
- C. 1 ea. Passenger side mounting bracket
- D. 12 ea. Hex head bolts M12x1.75x40mm
- E. 12 ea. Hex head nuts M12x1.75
- F. 12 ea. Split Washer M12
- G. 24 ea. Flat washer M12
- H. 4 ea. M12 Large flat washer

TOOLS NEEDED

- Socket drive
- 21mm socket
- 13mm wrench
- 15mm socket
- 18mm deep socket
- 19mm wrench

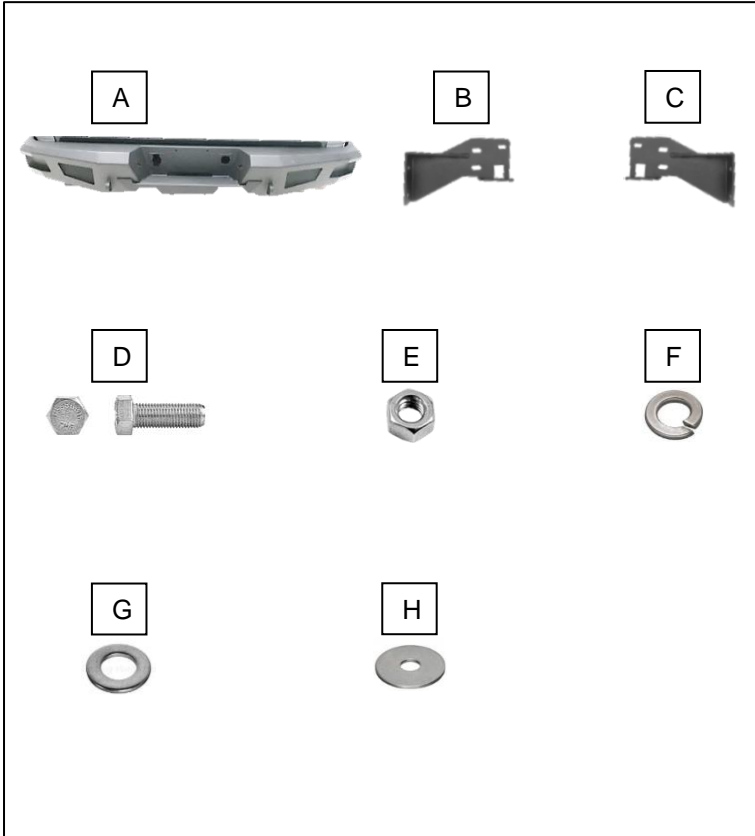

Product shown installed on GMC Sierra 1500



Please take a few minutes to read and thoroughly familiarize yourself with the installation procedures outlined in this manual. Following the steps as outlined will save you time and help reduce mistakes. Once the instructions are reviewed, if you feel that you are not capable of safely installing the parts seek the help of a qualified installation expert to help you complete the job. The manufacture is in no way responsible for any personal injury or vehicle damage that may occur during the installation.

California Proposition 65 Warning!

This product may contain lead a chemical known to the State of California to cause cancer and birth defects or other reproductive harm. For more information go to www.P65Warnings.ca.gov.

FACTORY BUMPER REMOVAL



Step 1.
Working underneath the vehicle. On each side of the bumper you will need to locate 3 factory bolts.

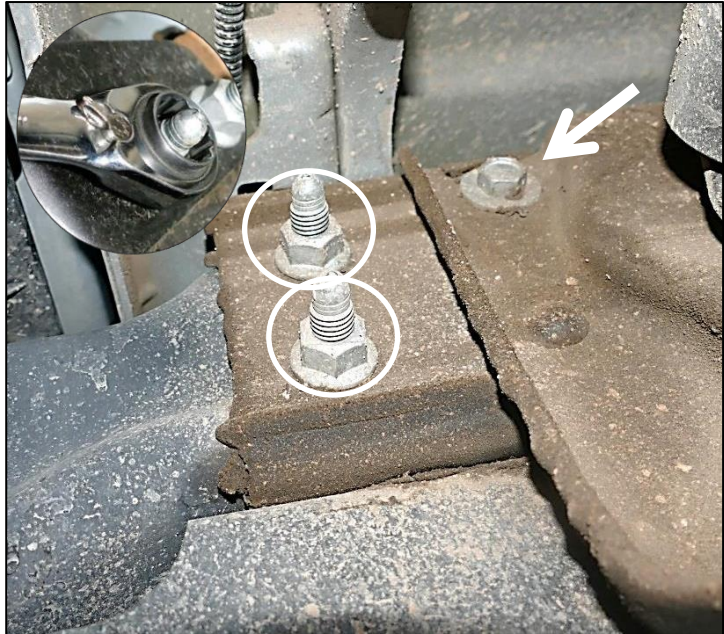

Step 2.
Using a 19mm socket locate and remove 2 factory bolts circled above. Remove top right bolt using a 15mm socket. Repeat step for other side. Set factory hardware aside for reinstallation.



Step 3.
Using a 21mm socket locate and remove two factory bolts holding factory bumper onto hitch. Discard hardware.

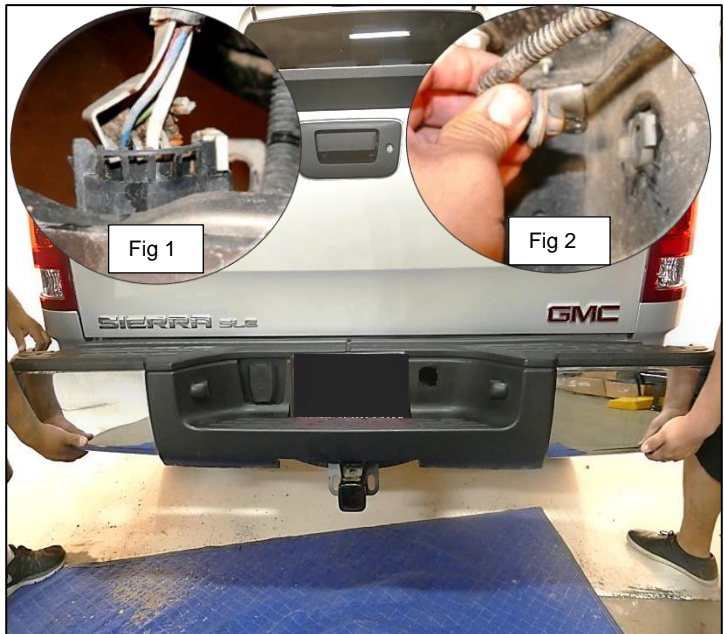

Step 4.
Locate and remove the locking clip to unplug the trailer harness fig 1. Disconnect factory license plate light from bumper fig 2. With help from an assistant remove bumper from vehicle. Set bumper aside for later use.

FACTORY BUMPER REMOVAL continued

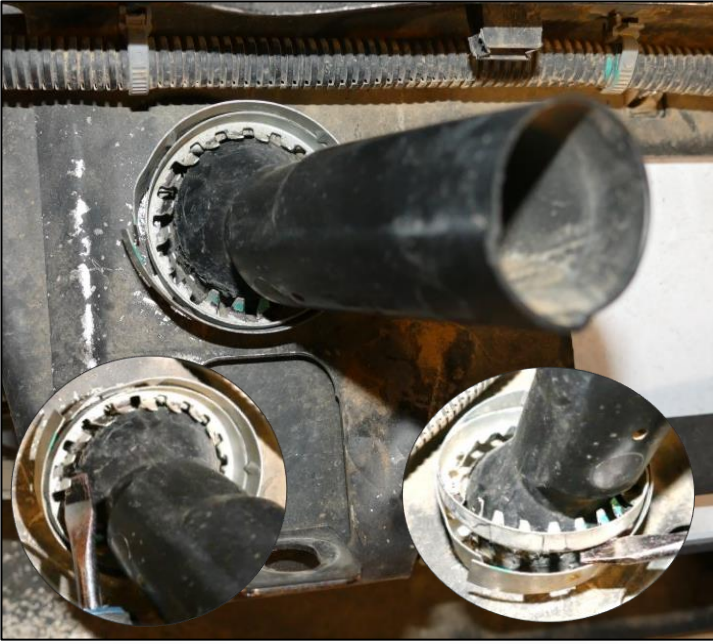

Step 5.
Proceed to your work bench. Working behind bumper locate and remove middle ring holding spare tire access housing onto bumper using a flat head screwdriver. Remove spare tire access housing. Set middle ring and spare tire access housing aside for later use.

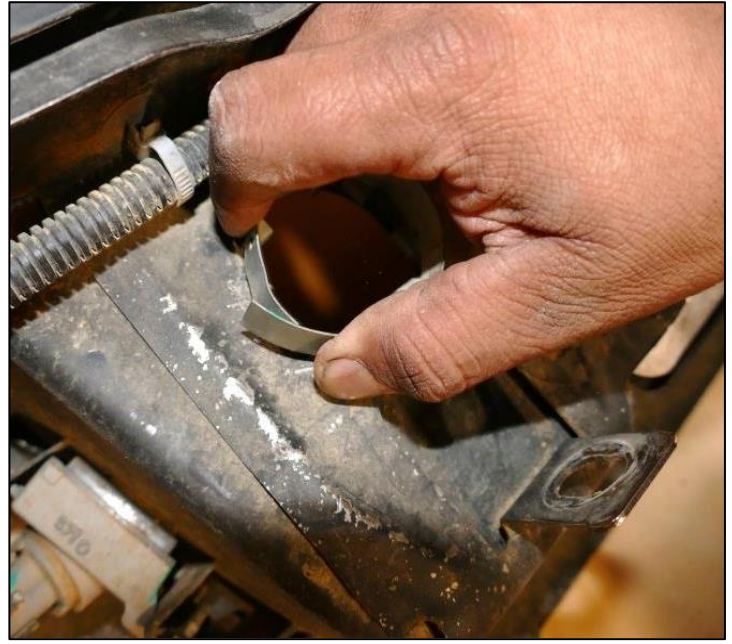

Step 6.
Remove outer ring by pressing firmly on all side of the outer ring. Set outer ring aside for reinstallation.

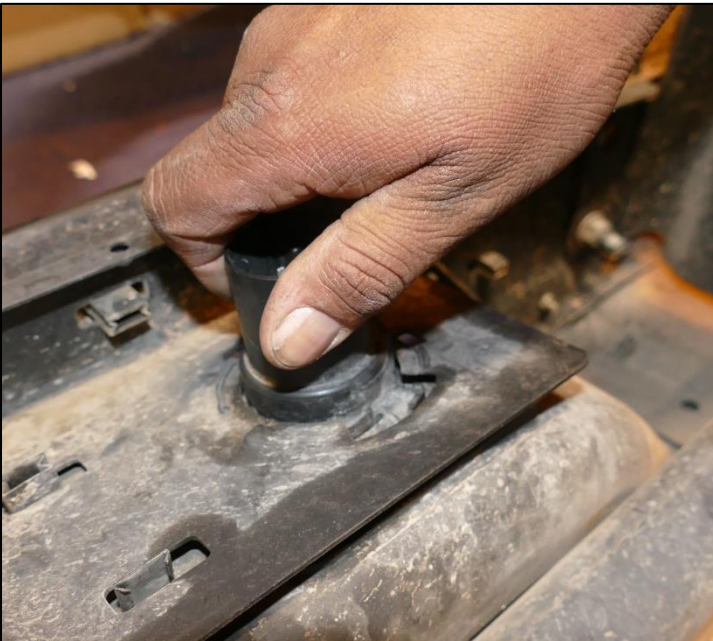

Step 7.
Firmly grab factory hitch harness and twist until it unlocks from the factory bumper. Set trailer plug aside for later use.



Step 8.
Remove factory license plate light housing by releasing the clips using a flat head screw driver. Repeat step for other side. Set factory license plate light housing aside for later use.

INSTALLING MOUNTING BRACKET



Step 1.
Install driver side mounting bracket (B) onto vehicle as shown. Line up the holes in the mounting bracket with the holes in the vehicle frame.



Step 2.
Install factory hardware removed in step 2 removal process through the holes in the mounting bracket (C) and through the holes in the vehicle frame.

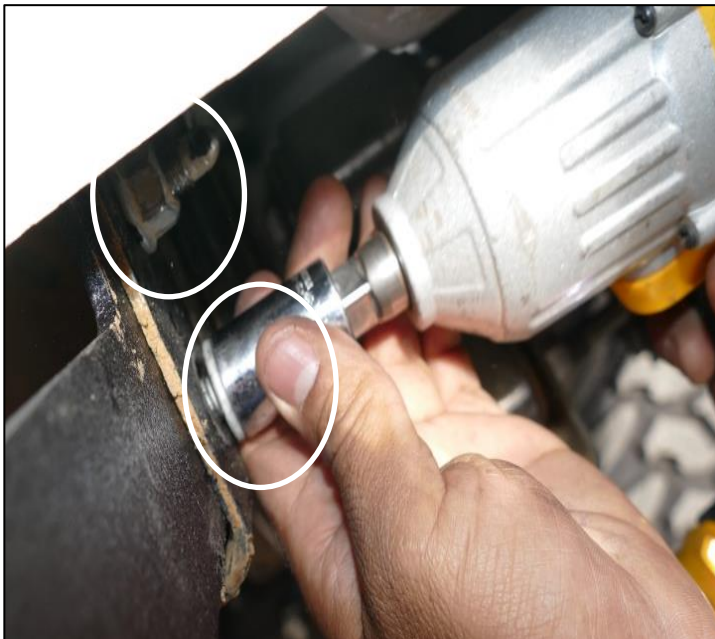

Step 3.
Start factory nuts at the end of the bolts. Using a 18mm socket tighten down nuts.



Step 4.
Locate and place supplied hex head bolt M12x1.75 40mm (D) with supplied M12 flat washer (H) through the hole in the mounting bracket. Place a supplied M12 large flat washer (H) at the end of bolt. Start a supplied M12x1.75 hex head nut (E) at the end of bolt. Tighten down using a 18m socket. Repeat step for other side mounting bracket.

INSTALLING NEW BUMPER



Step 1.
Working behind the bumper. Place outer ring onto supplied bumper (A) as shown.



Step 2.
Place spare tire access into supplied bumper (A).



Step 3.
Working behind supplied bumper (A). Install inner ring into outer ring as shown above to secure spare tire access housing onto supplied bumper (A).



Step 4.
Place factory hitch harness into shaped hole on supplied bumper (A). Twist trailer plug until it locks in place.

INSTALLING REAR BUMPER continued



Step 5.
With help from an assistant place supplied rear bumper (A) onto vehicle. Reinstall the hitch receiver locking clip onto hitch harness. Line up bumper holes with mounting bracket holes.



Step 6.
Locate and place supplied hex head bolt M12x1.75 40mm (D) with supplied M12 flat washer (G) from behind mounting bracket holes and through the bumper (A) holes fig 1. Place a supplied M12 flat washer (G) and supplied M12 split washer (F) at the end of bolt. Start a supplied M12x1.75 hex head nut (E) at the end of bolt. Tighten down using 18mm socket. Repeat step for remaining bolt. Repeat same step for other side of bumper.



Step 7.
Place factory license plate light housing onto bumper (A) as shown. Firmly press down until it locks into position. Repeat step for other license plate housing.



Step 8.
Reconnect license plate light back onto light housing. Repeat step for other side.

This completes the installation.