

PARTS LIST: SD0176

2	I-4 Running Boards	16	8mm Lock Washers
4	Left or Right Mounting Brackets	8	8mm Hex Nuts
4	Plastic Bracket Covers	8	6mm T-Bolts
8	Plastic Clips for Covers	8	6mm x 22mm OD x 2mm Flat Washers
8	8mm Clip Nuts	8	6mm Lock Washers
16	8-1.25mm x 30mm Hex Bolts	8	6mm Hex Nuts
24	8mm ID x 24mm OD x 2mm Flat Washers		

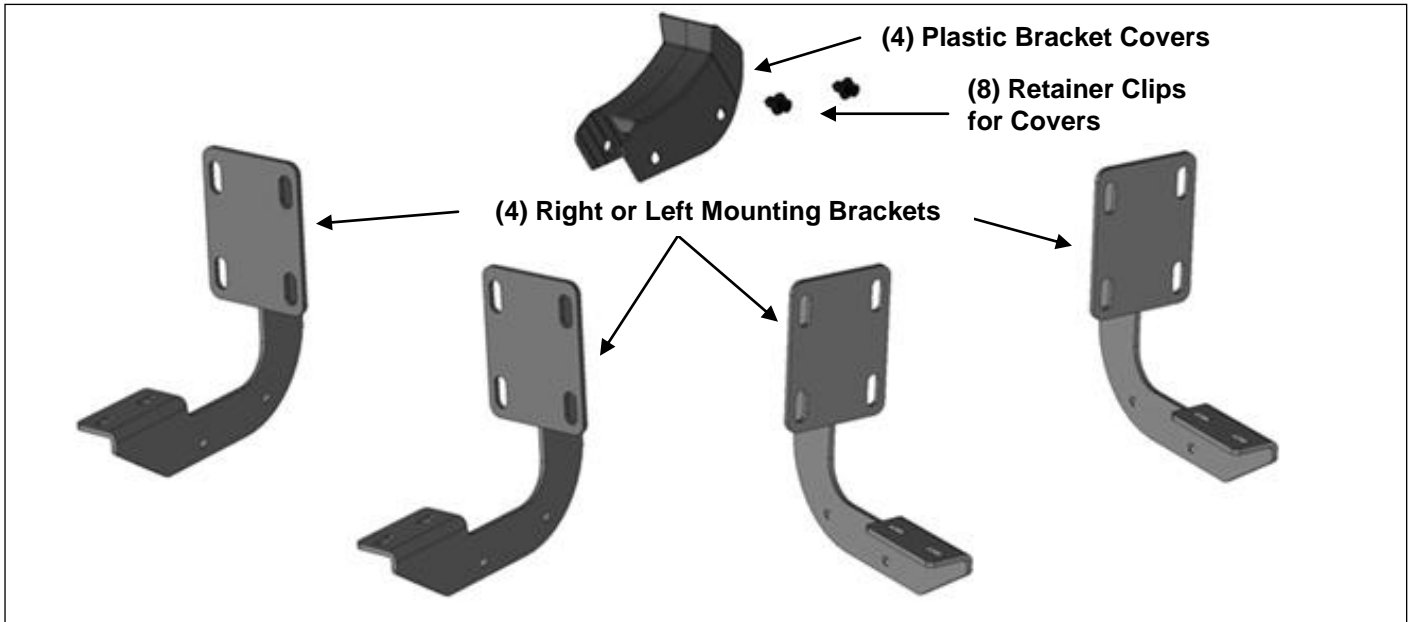

PROCEDURE:

- 1. REMOVE CONTENTS FROM BOX. VERIFY ALL PARTS ARE PRESENT. READ INSTRUCTIONS CAREFULLY BEFORE STARTING INSTALLATION.**
- Starting on the passenger side-front of the vehicle, locate the 2nd set of factory holes in the body panel and pinch weld directly under the center of the front door, **(Figure 1)**. Each mounting location is comprised of a rectangular hole with a round hole on each side and two holes in pinch weld, **(Figure 2)**.
- Select (2) 8mm Clip Nuts. Insert Clip Nuts one at a time into the rectangular opening and slide the threaded hole outward towards the round hole. Line up the threaded hole in the Clip with the round hole next to the rectangular opening. **NOTE:** Threaded nut must go towards the inside of the side panel, **(Figures 3 & 4)**.
- Select (1) Mounting Bracket. **NOTE:** All (4) Brackets are universal and will fit left or right side. Attach the Bracket to the Clip Nuts with the included (2) 8mm x 30mm Hex Bolts, (2) 8mm Lock Washers and (2) 8mm Flat Washers, **(Figures 5 & 6)**
- Attach the (2) bottom holes in the Mounting Bracket to the (2) holes in the pinch weld with the included (2) 8mm x 30mm Hex Bolts, (4) 8mm Flat Washers, (2) 8mm Lock Washers and (2) 8mm Hex Nuts, **(Figures 5 & 6)**. **NOTE:** Insert the Hex Bolt with Flat Washer through pinch weld first then through the Bracket from outside to inside. Do not tighten hardware at this time.
- Next, select (1) Plastic Cover and (2) Cover Clips, **(Figure 7)**. Slide the Cover over the top of the Bracket and line up the (2) holes in the cover with the holes in the Bracket. Insert the Cover Clips into the holes. Push the center pin in on each clip until it is flush against the outer ring to expand the clip in the hole, **(Figure 7)**. **NOTE:** Loosen the Bracket if necessary to attach the Cover.

7. Move to the last set of mounting holes at the back of the cab, **(Figure 2)**. Repeat **Steps 2—6** for rear Mounting Bracket installation, **(Figure 8)**.
8. Select (1) Running Board and (6) 6mm T-Bolts. Locate the opening in the end of each channel in the bottom of the Running Board. Slide (3) T-Bolts into each channel, **(Figure 9)**.
9. With assistance, carefully position the Running Board onto the (3) Mounting Brackets. Lift the Running Board up and slide the T-Bolts along the channels to line up with the Brackets.
IMPORTANT: Do not slide the Running Board on the Brackets, (front to back or rotate), or the finish on the Running Board may be damaged.
10. Line up the front of the Running Board approximately 2" back, (or locate as desired), from the front wheel opening or mud flap if equipped. Attach the Running Board to the Brackets with (6) 6mm Flat Washers, (6) 6mm Lock Washers and (6) 6mm Hex Nuts, **(Figures 10 & 11)**. Do not tighten hardware.
11. Level and adjust the Running Board and tighten all hardware.
12. Repeat **Steps 2—11** for driver/left Running Board installation.
13. Do periodic inspections to the installation to make sure that all hardware is secure and tight.

To protect your investment, wax this product after installing. Regular waxing is recommended to add a protective layer over the finish. Do not use any type of polish or wax that may contain abrasives that could damage the finish. Mild soap may be used to clean the Running Board.

Passenger Side Installation Pictured

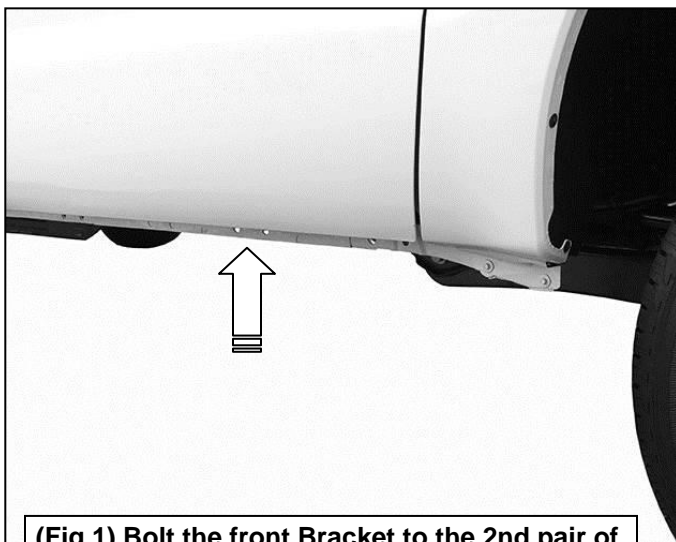

(Fig 1) Bolt the front Bracket to the 2nd pair of factory holes in the bottom of the pinch weld

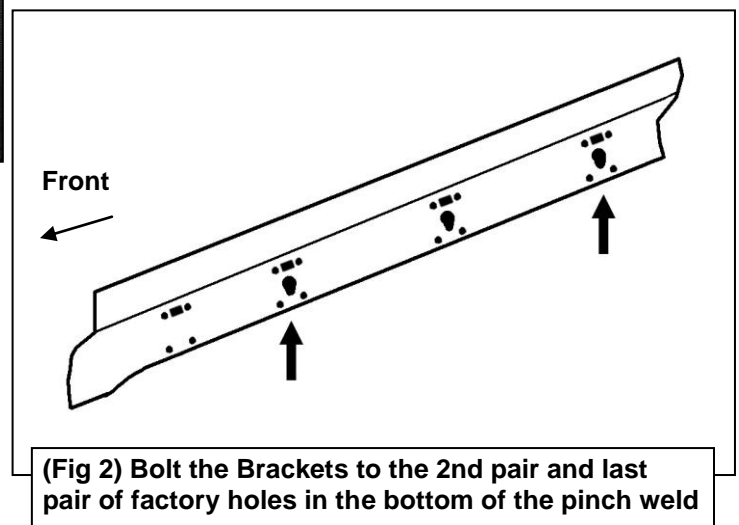

(Fig 2) Bolt the Brackets to the 2nd pair and last pair of factory holes in the bottom of the pinch weld

Passenger Side Installation Pictured

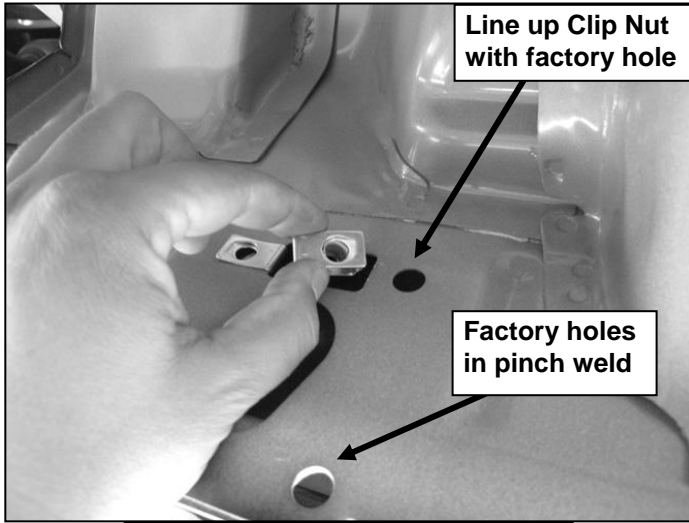

(Fig 3) Typical Mounting Location

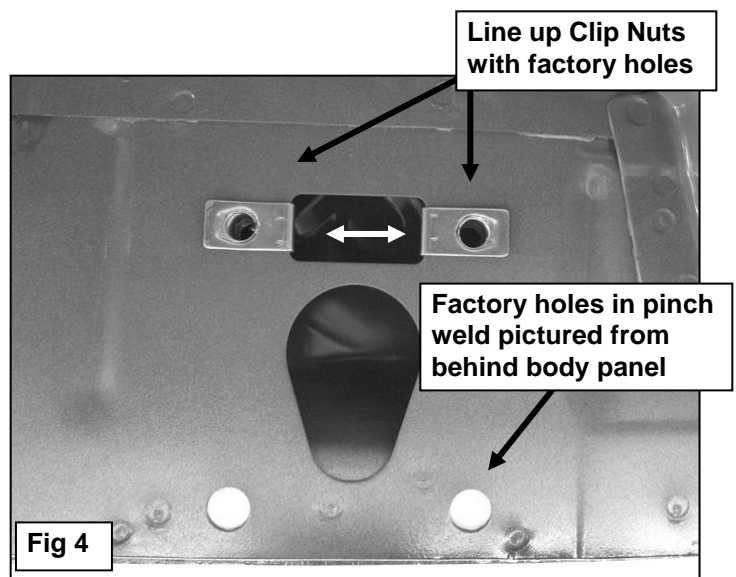
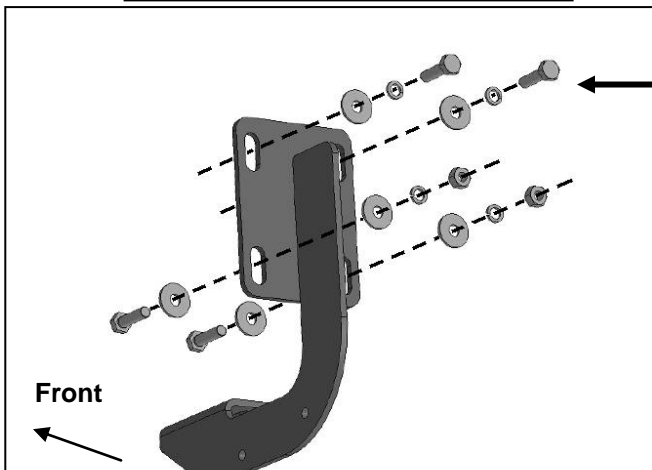

Fig 4



(Fig 5) Passenger/right front Bracket installation

- (2) 8mm Clip Nuts
- (2) 8mm x 30mm Hex Bolts
- (2) 8mm Lock Washers
- (2) 8mm Flat Washers

- (2) 8mm x 30mm Hex Bolts
- (4) 8mm Flat Washers
- (2) 8mm Lock Washers
- (2) 8mm Hex Nuts

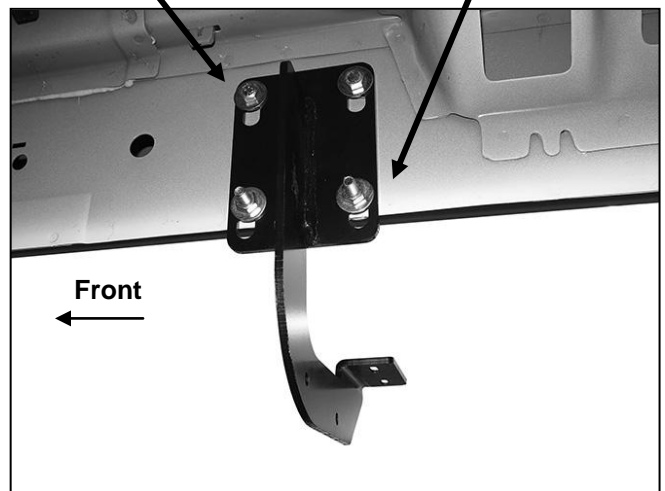

(Fig 6) Passenger/right front Bracket installation

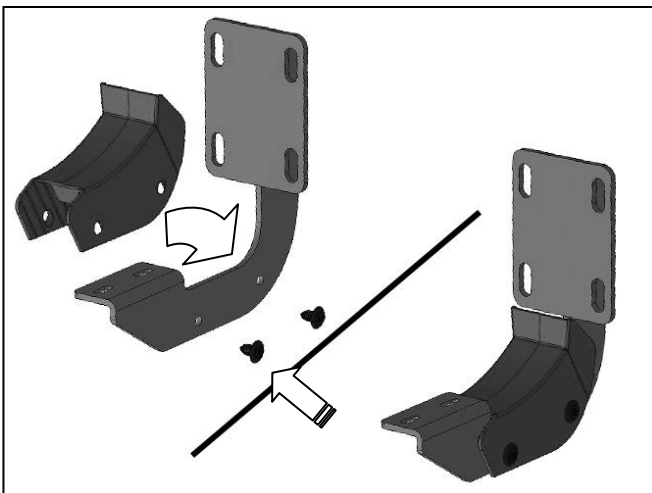

(Fig 7) Slide Cover over top of Bracket. Attach Cover to Bracket with (2) Retaining Clips

Passenger Side Installation Pictured

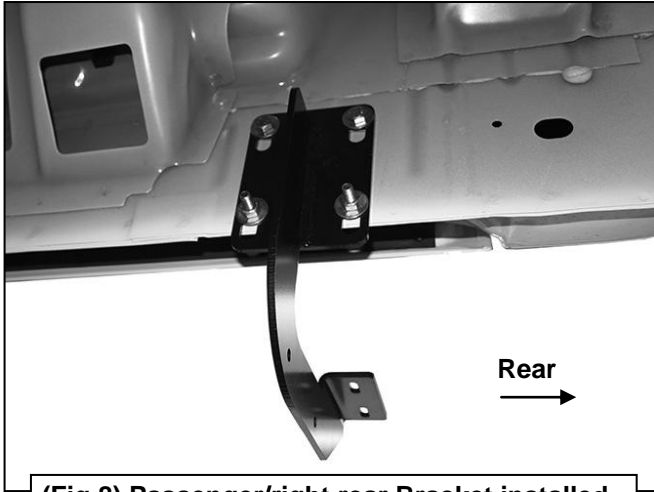

(Fig 8) Passenger/right rear Bracket installed

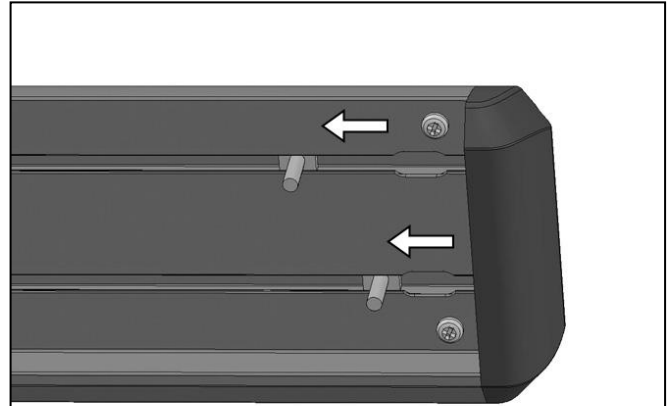

(Fig 9) Slide T-Bolts into slots in Running Board

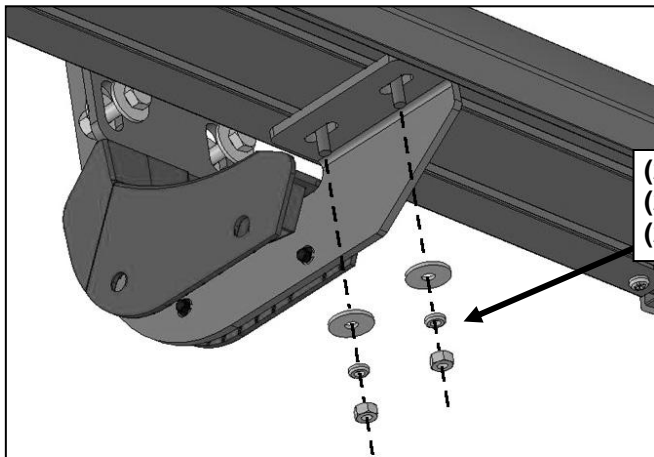

- (2) 6mm Flat Washers
- (2) 6mm Lock Washers
- (2) 6mm Hex Nuts

(Fig 10) Attach Running Board to Brackets



(Fig 11) Passenger/right front installation



Complete Installation