

PARTS LIST:

1	76" Driver/left side S6 Running Board	12	8-1.25mm "U" Clips
1	76" Passenger/right side S6 Running Board	48	8mm x 24mm x 2mm Flat Washers
6	Mounting Brackets	24	8mm Lock Washers
6	8-1.25mm x 35mm Double Bolt Plates	12	8-1.25mm Hex Nuts
24	8-1.25mm x 30mm Hex Bolts	12	8-1.25mm Nylon Lock Nuts

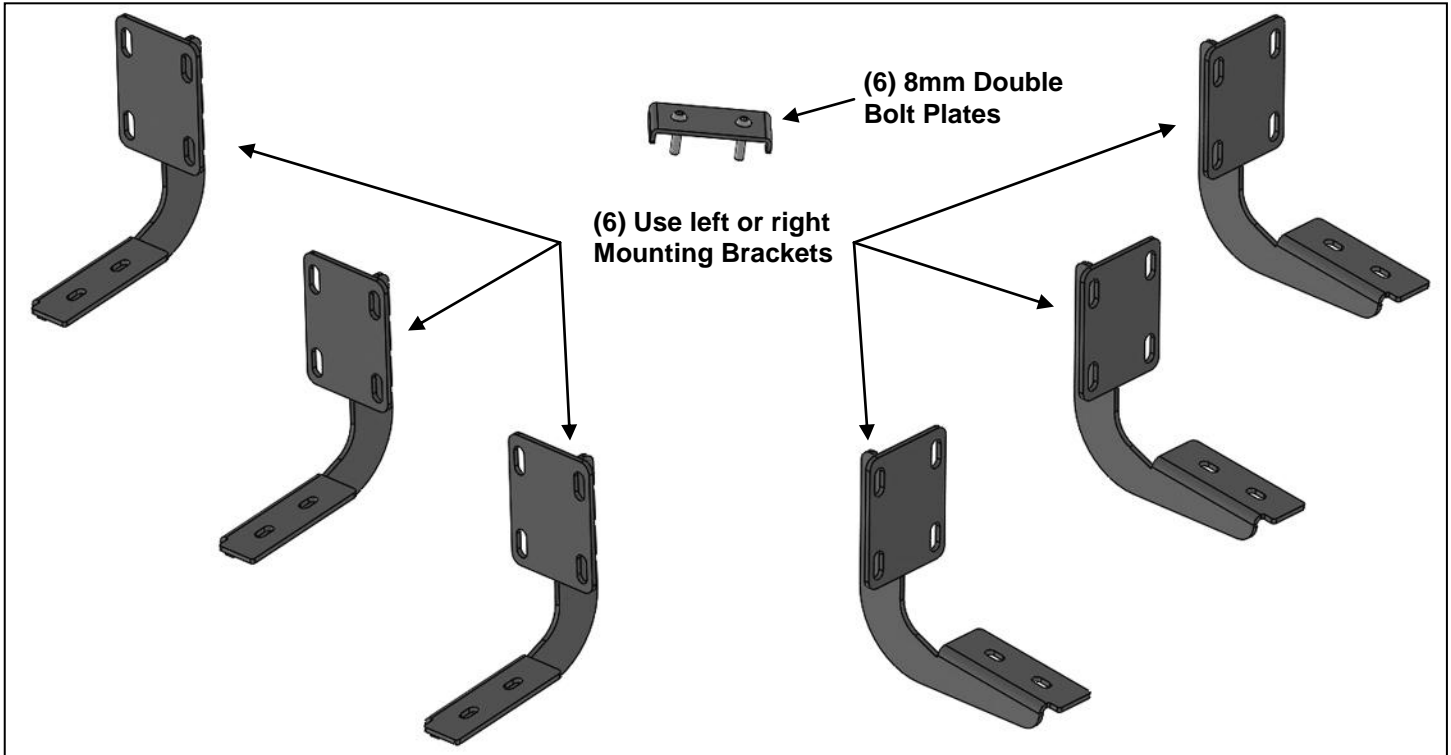

PROCEDURE:

- 1. REMOVE CONTENTS FROM BOX. VERIFY ALL PARTS ARE PRESENT. READ INSTRUCTIONS CAREFULLY BEFORE STARTING INSTALLATION.**
- Starting on the driver front side of the body panel, locate the rectangular opening and the (2) small holes in the inner body panel directly above the (2) holes in the pinch weld, **(Figures 1 & 2)**. **NOTE:** The holes in the inner panel may be covered with sealing tape or insulation, remove as required.
- Slide (2) 8mm "U" Clips into the rectangular opening with the nut towards the inside. Line up the threaded nut on the clips with the (2) small round holes, **(Figure 3)**.
- Select (1) Mounting Bracket. Attach the top of the Bracket to the "U" Clips with (2) 8mm Hex Bolts, (2) 8mm Lock Washers and (2) 8mm Flat Washers, **(Figures 4 & 5)**. Line up the lower holes in the Bracket with the (2) holes through the pinch weld. Bolt the Bracket to the pinch weld with (2) 8mm Hex Bolts, (4) 8mm Flat Washers, (2) 8mm Lock Washers and (2) 8mm Hex Nuts, **(Figures 4 & 5)**. Snug but do not fully tighten Bracket hardware.
- Continue along the body panel toward the center mounting location, **(Figure 1)**. Repeat **Steps 2—4** to install (1) Mounting Bracket on the center location.
- Move toward the rear of the cab, **(Figure 6)**. Locate the last pair of holes along the pinch weld. Use **Figure 1** to determine the correct mounting location for the rear Bracket. Repeat **Steps 2—4** to install (1) Mounting Bracket on the rear location, **(Figure 7)**.
- Once the (3) Brackets have been fully installed, select the driver/left side Running Board. **NOTE:** The front stepping pad is farther away from the front end of the Running Board. Place the Running Board on top of the Brackets. Locate the channel in the bottom of the Running Board. Select (3) 8mm Double Bolt Plates, **(Figure 8)**. Insert the Bolt Plates into the channel in the bottom of the Running Board closest to the Brackets, **(Figure 9)**. Lift the Board up and guide the studs through the Brackets.

8. Attach the Running Board to the Brackets with (6) 8mm Flat Washers and (6) 8mm Nylon Lock Nuts, (Figures 10—12).
9. Level and adjust the Running Board as necessary and fully tighten all hardware.
10. Repeat **Steps 2—9** for passenger/right side Running Board installation.
11. Do periodic inspections to the installation to make sure that all hardware is secure and tight.

To protect your investment, wax this product after installing. Regular waxing is recommended to add a protective layer over the finish. Do not use any type of polish or wax that may contain abrasives that could damage the finish. Mild soap may be used to clean the Running Board.

Driver/left Side Installation Pictured

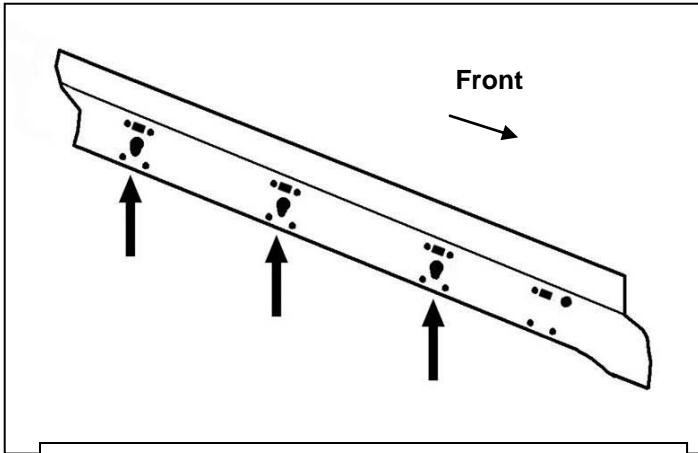

(Fig 1) Driver/left side mounting area illustrated

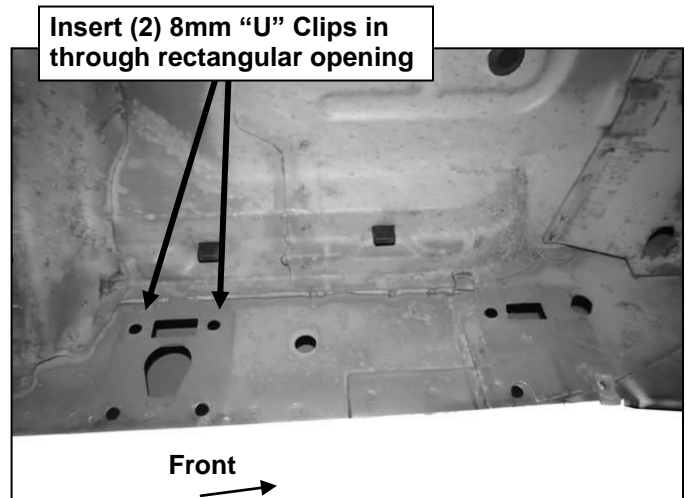

(Fig 2) Driver/left side Front mounting location

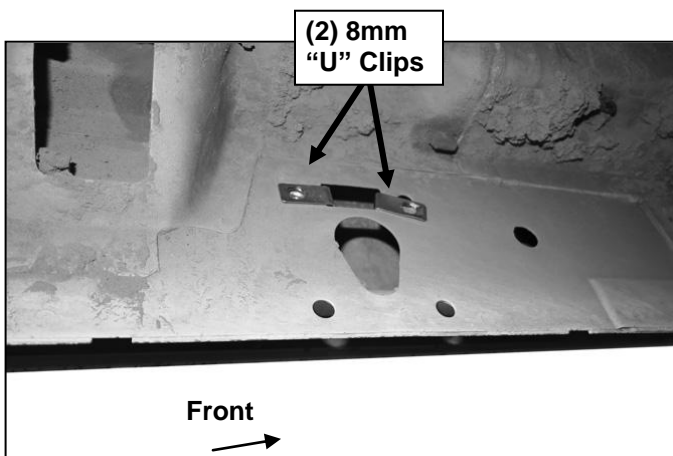

(Fig 3) Line up the (2) 8mm "U" Clips with the (2) small holes next to the rectangular opening

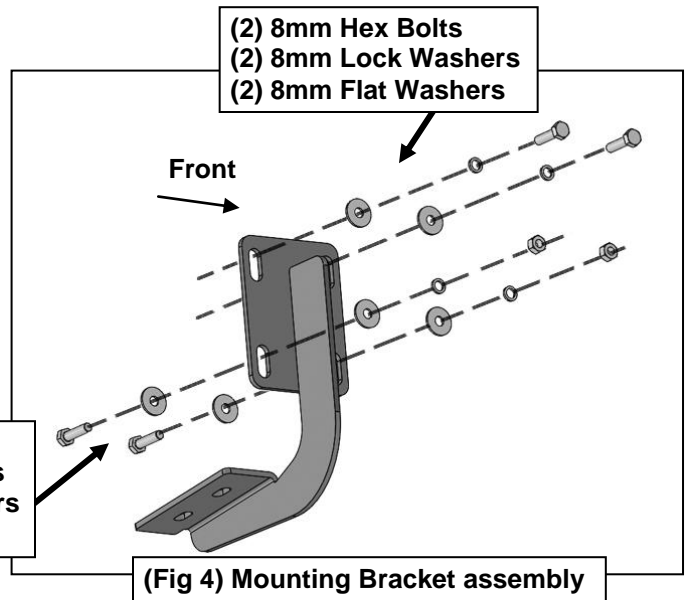

- (2) 8mm Hex Bolts
- (4) 8mm Flat Washers
- (2) 8mm Lock Washers
- (2) 8mm Hex Nuts

(Fig 4) Mounting Bracket assembly

Driver/left Side Installation Pictured

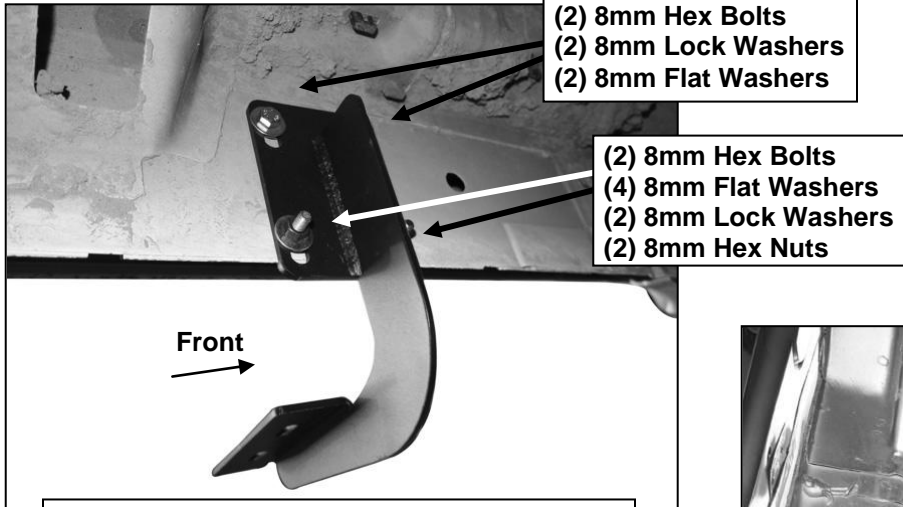

(Fig 5) Driver/left side front Bracket installed

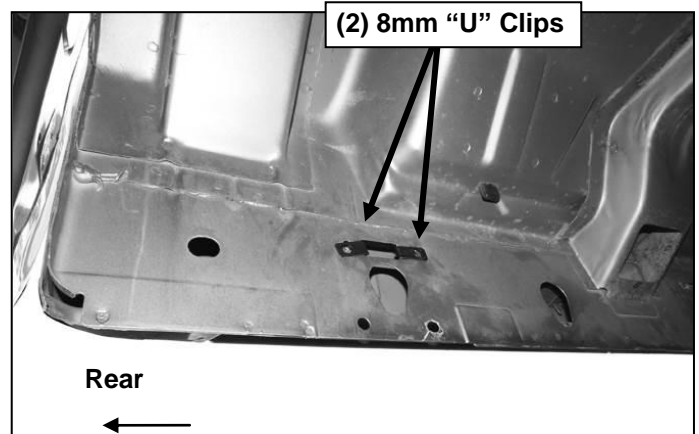

(Fig 6) Driver/left side rear mounting location

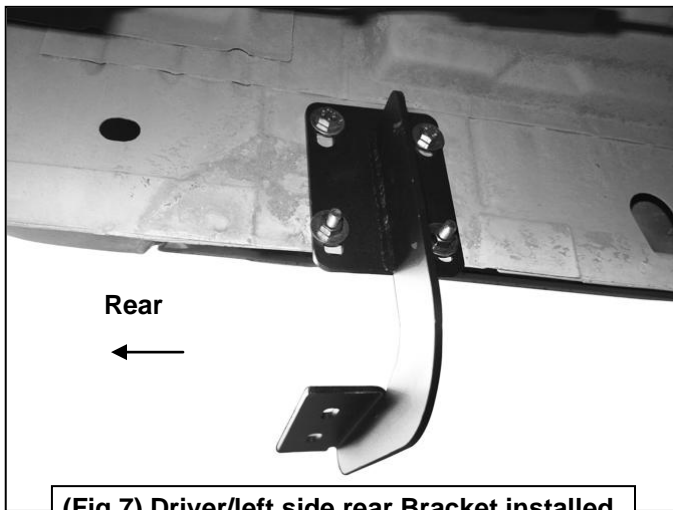

(Fig 7) Driver/left side rear Bracket installed

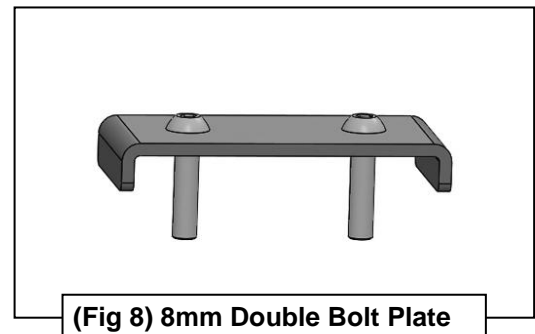
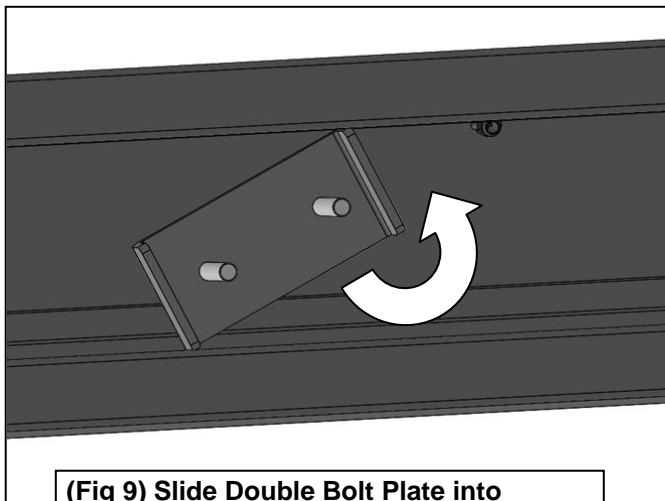

Driver/left Side Installation Pictured

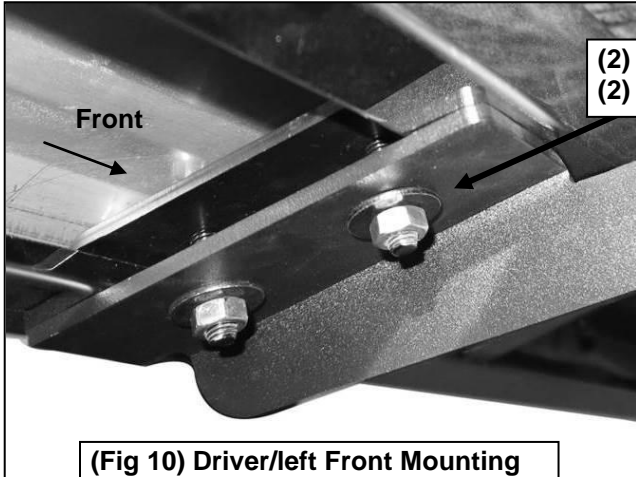

(2) 8mm Flat Washers
(2) 8mm Nylon Lock Nuts

(Fig 10) Driver/left Front Mounting Bracket attached to Board pictured

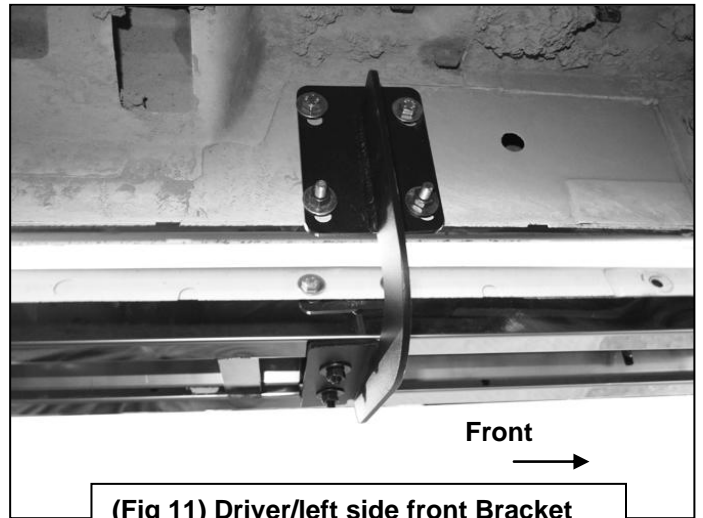

(Fig 11) Driver/left side front Bracket attached to Running Board

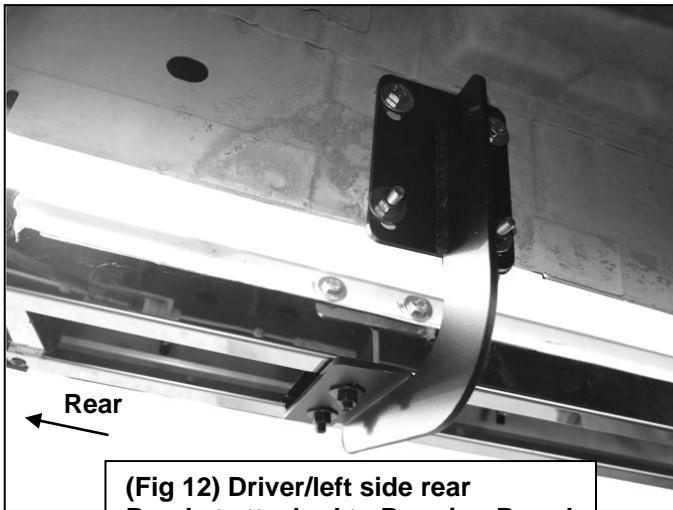

(Fig 12) Driver/left side rear Bracket attached to Running Board

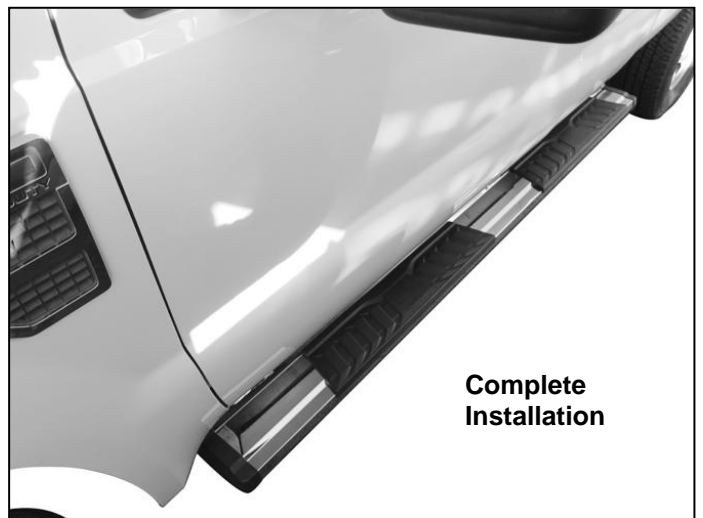

Complete Installation