

S6 RUNNING BOARDS (15-18 F150 SuperCrew)

PARTS LIST:

2	91" S6 Running Boards	30	8mm x 24mm x 2mm Washers
6	Universal Mounting Brackets (left or right)	30	8-1.25mm Nylon Lock Nuts
18	8mm Plastic Washers	6	8mm Double Bolt Plates

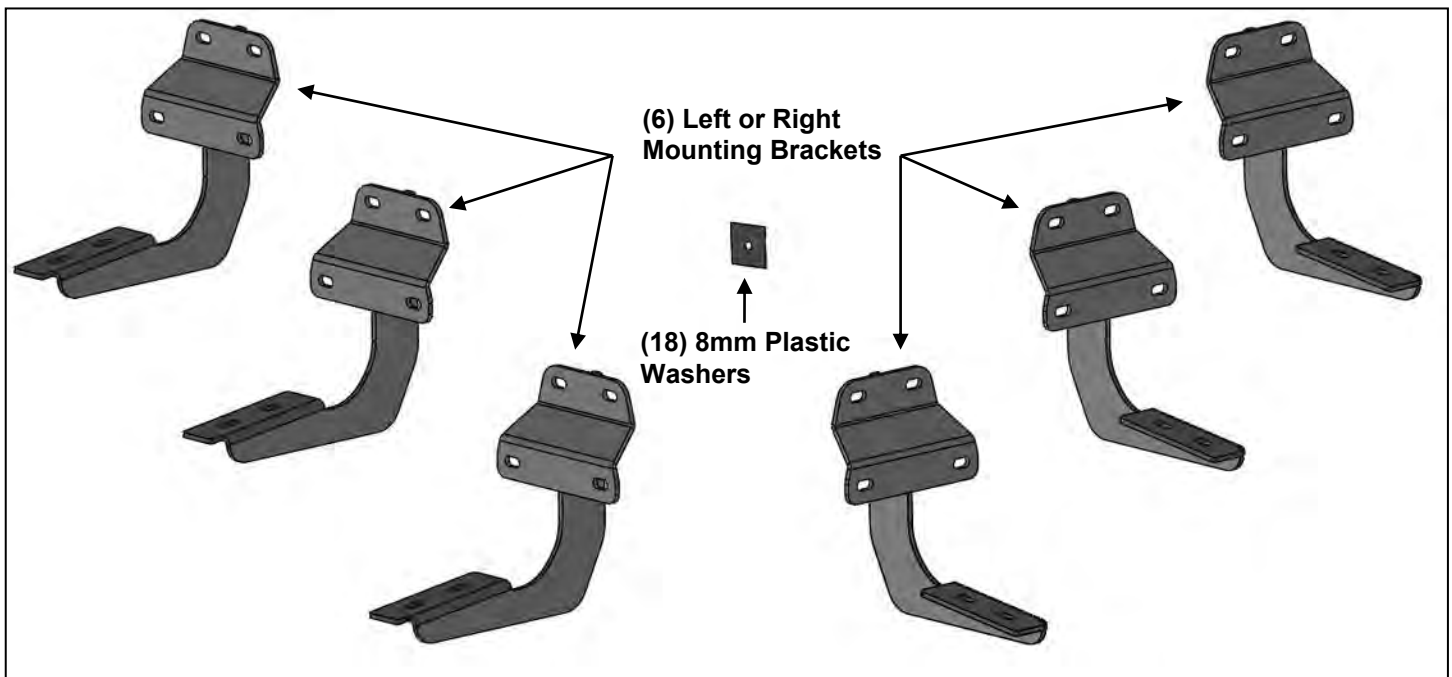

PROCEDURE:

REMOVE CONTENTS FROM BOX. VERIFY ALL PARTS ARE PRESENT. READ INSTRUCTIONS CAREFULLY BEFORE STARTING INSTALLATION. ASSISTANCE IS RECOMMENDED.

1. Start the installation under the driver side of the vehicle. Locate the front factory running board mounting location along the inner side of the body, **(Figure 1)**.
2. Slide (1) Plastic Washer over each of the (3) factory mounting studs in the body panel, **(Figures 2 & 3)**. **IMPORTANT:** The Plastic Washers are designed to prevent corrosion between the aluminum body panel and the steel mounting brackets. **Do not install the Brackets without the Plastic Washers.**
3. Select (1) Mounting Bracket. **NOTE:** All (6) Brackets are universal and will fit left or right side. Attach the Mounting Bracket to the (3) factory studs with (3) 8mm Flat Washers and (3) 8mm Nylon Lock Nuts, **(Figures 4 & 5)**. Leave brackets loose at this time.
4. Repeat **Steps 1—3** to install the center and rear passenger side Brackets, **(Figures 6 & 7)**.
5. Select (1) S6 Running Board. Place the Running Board on top of the Brackets. Locate the channel in the bottom of the Running Board. Select (3) 8mm Double Bolt Plates, **(Figure 8)**. Insert the Bolt Plates into the channel in the bottom of the Running Board closest to the Brackets, **(Figure 9)**. Lift the Running Board up and guide the studs through the Brackets.
6. Attach the Running Board to the Brackets with (6) 8mm Flat Washers and (6) 8mm Nylon Lock Nuts, **(Figures 10—12)**. **NOTE:** The Running Board is designed to fit close to the vehicle. It

may be necessary to loosen the Bracket hardware slightly and tilt the Brackets downward to insert the Running Board between the Brackets and the body. Do not tighten hardware.

7. Level and adjust the Running Board as necessary and fully tighten all hardware.
8. Repeat **Steps 1—7** for the passenger side Running Board installation.
9. Do periodic inspections to the installation to make sure that all hardware is secure and tight.

To protect your investment, wax this product after installing. Regular waxing is recommended to add a protective layer over the finish. Do not use any type of polish or wax that may contain abrasives that could damage the finish. Mild soap may be used also to clean the Running Board.

Driver/Left Side Installation Pictured

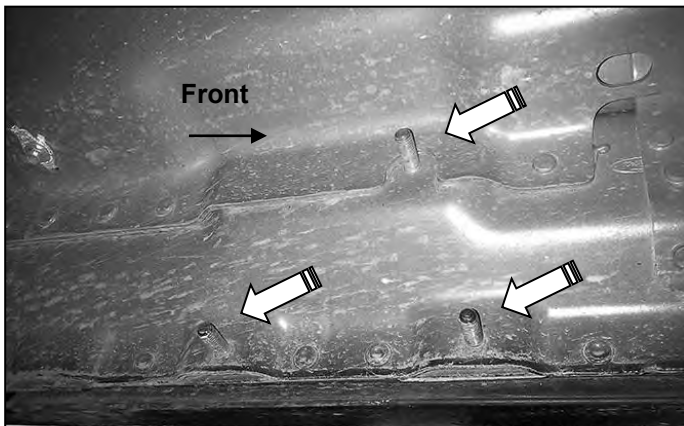

(Fig 1) Driver/left side front mounting location



(Fig 2) Plastic Insulation Washer

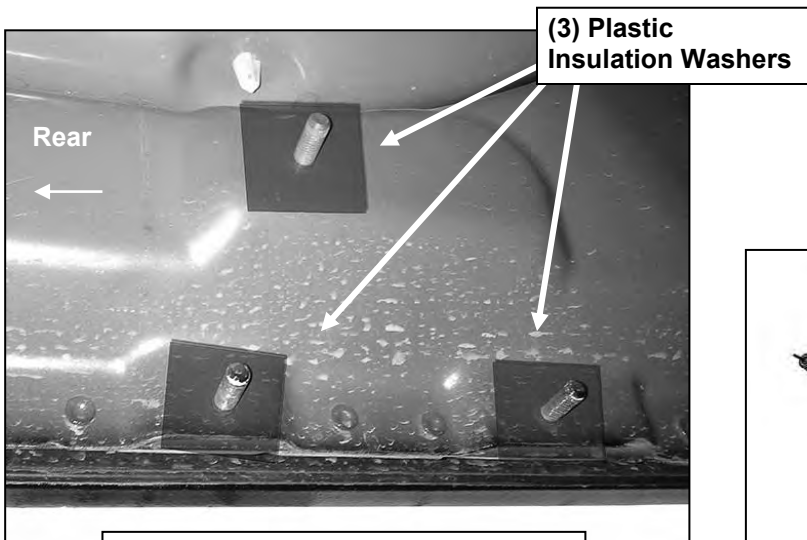

(Fig 3) Thread Plastic Washers onto all mounting studs. Driver side rear mounting location pictured

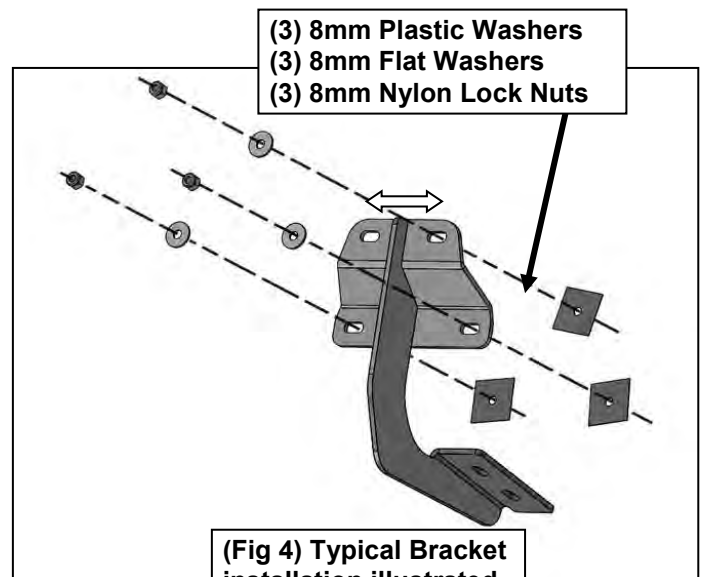

(Fig 4) Typical Bracket installation illustrated

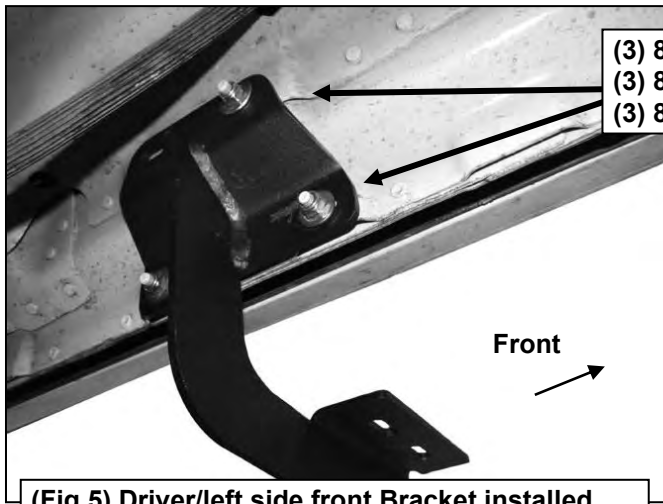

(Fig 5) Driver/left side front Bracket installed

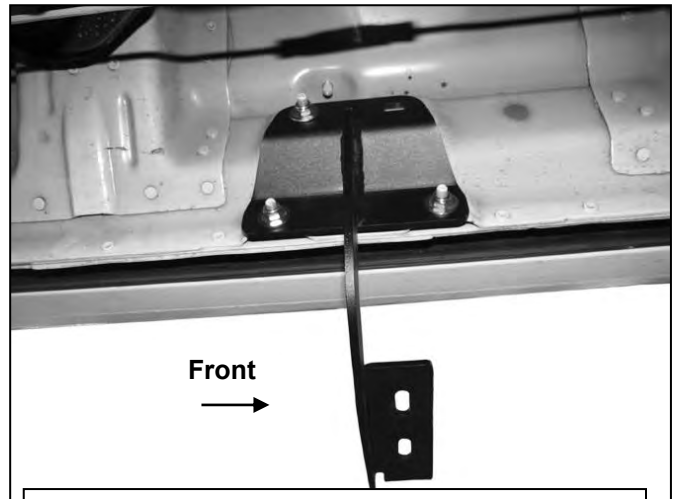

(Fig 6) Driver/left side center Bracket installed

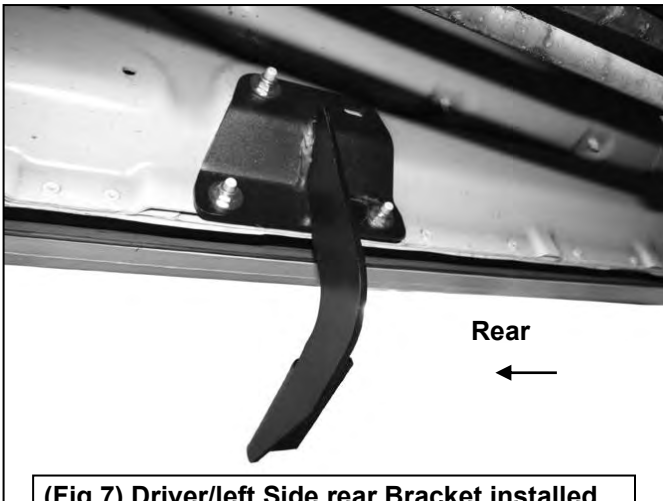

(Fig 7) Driver/left Side rear Bracket installed

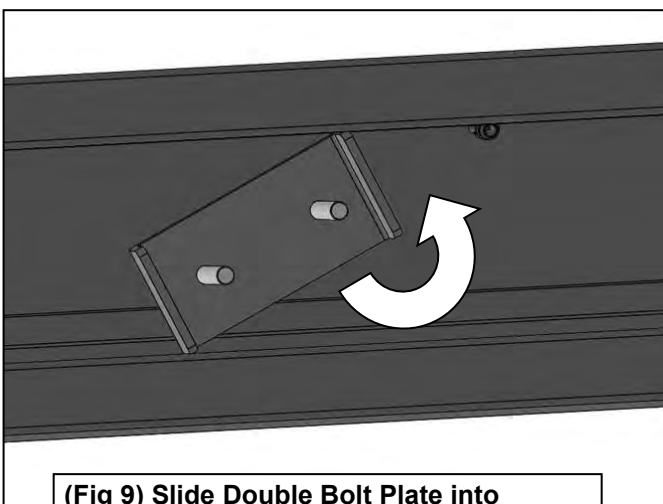

(Fig 9) Slide Double Bolt Plate into channel on the bottom of Running Board

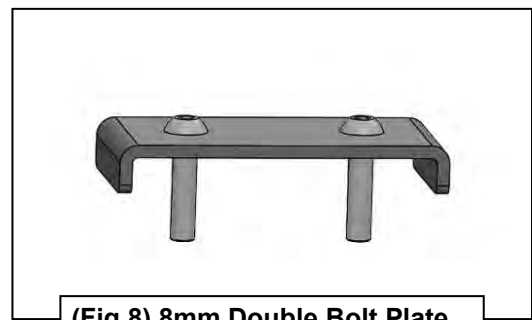

(Fig 8) 8mm Double Bolt Plate

(2) 8mm Flat Washers
(2) 8mm Nylon Lock Nuts

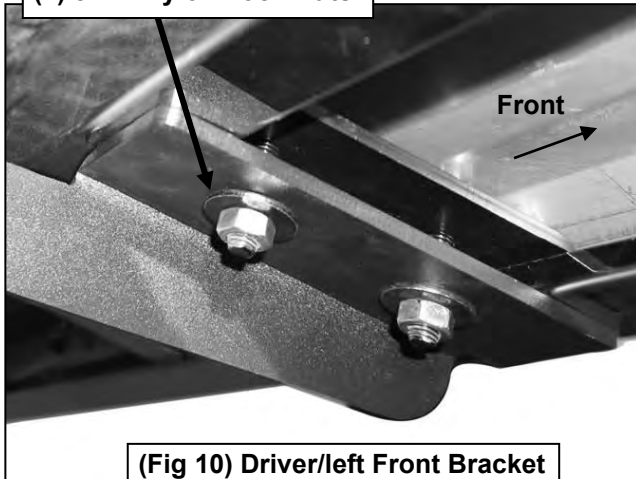

(Fig 10) Driver/left Front Bracket attached to Board pictured

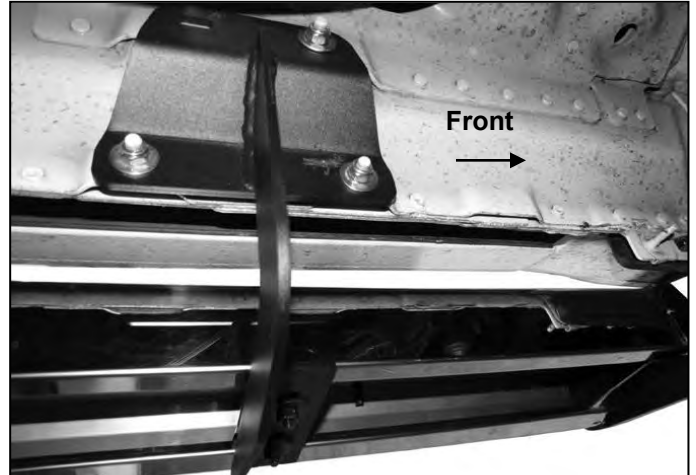

(Fig 11) Driver/left side front complete installation

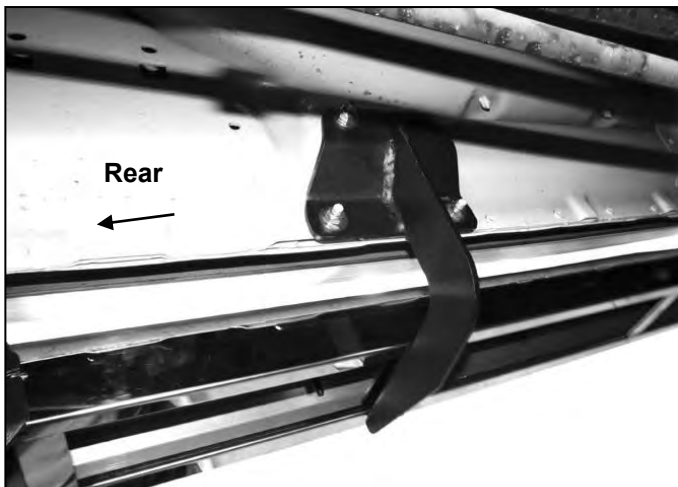

(Fig 12) Driver/left side rear complete installation



Complete Installation