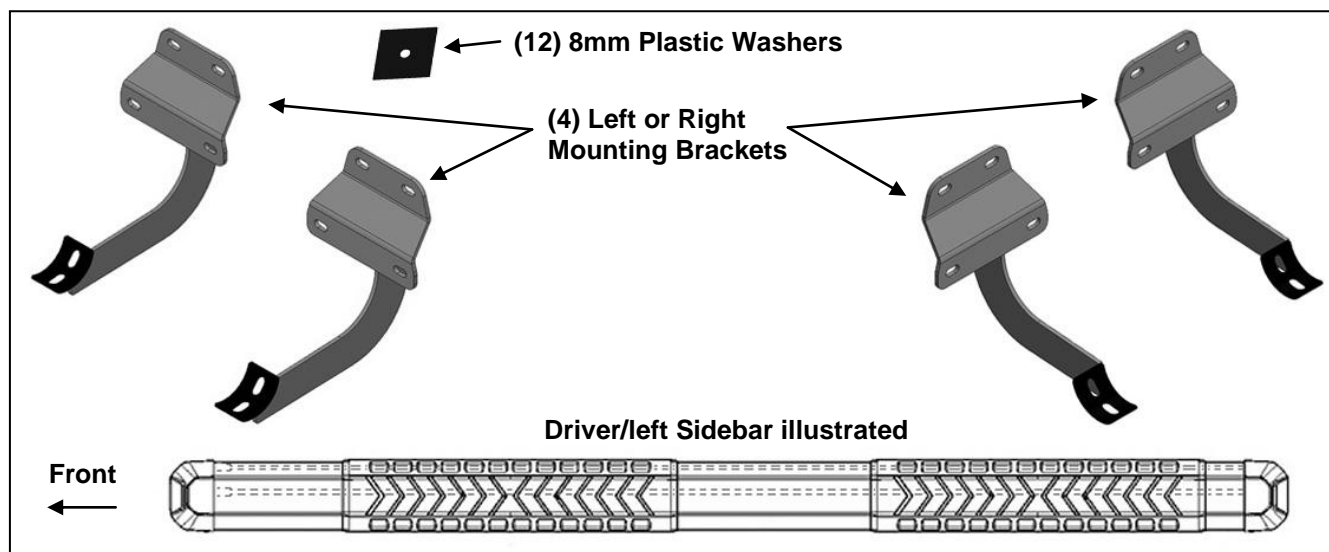

15-18 Ford F150 Super Cab

17-18 F250/350/450/550 SUPER DUTY SUPER CAB

5" Saber SS and AL Side Bars**PARTS LIST:**

1	Driver/left Saber Sidebar	20	8mm x 24mm OD x 2mm Washers
1	Passenger/right Saber Sidebar	8	8mm Lock Washers
4	Sidebar Brackets (use for left or right)	12	8-1.25mm Nylon Lock Nuts
12	8mm Plastic Washers	8	8-1.25mm Hex Nuts
8	8mm T-Bolts		

**PROCEDURE:**

REMOVE CONTENTS FROM BOX. VERIFY ALL PARTS ARE PRESENT. READ INSTRUCTIONS CAREFULLY BEFORE STARTING INSTALLATION. ASSISTANCE IS RECOMMENDED.

1. Start the installation under the driver side of the vehicle. Locate the front factory running board mounting location along the inner side of the body, **(Figure 1)**.
2. Slide (1) Plastic Washer over each of the (3) factory mounting studs in the body panel, **(Figures 2 & 3)**. **IMPORTANT:** The Plastic Washers are designed to prevent corrosion between the aluminum body panel and the steel mounting brackets. **Do not install the Brackets without the Plastic Washers.**
3. Select (1) Mounting Bracket. **NOTE:** All (4) Brackets are universal and will fit left or right side. Attach the Mounting Bracket to the (3) factory studs with (3) 8mm Flat Washers and (3) 8mm Nylon Lock Nuts, **(Figure 4)**. Snug but do not fully tighten the hardware.
4. Repeat **Steps 1—3** to install the rear driver side Bracket.
5. Select the driver Sidebar. **NOTE:** Slots in the bottom of the Sidebar are offset toward the vehicle. Use the diagram above to help determine correct Sidebar.
6. Locate the opening in the end of each of the channels in the bottom of the Sidebar. Slide (2) 8mm T-Bolts into each channel, **(Figure 5)**. Carefully position the Sidebar onto the (2) Mounting Brackets. Lift the Sidebar up and slide the T-Bolts along the sidebar to match up with the Brackets. **IMPORTANT:** Do not slide the Sidebar on the Brackets, (front to back or rotate), or Sidebar may be damaged.

7. Line up the front of the Sidebar approximately 2" back, (or locate as desired), from the front wheel opening. Attach the Sidebar to the Mounting Brackets with (4) 8mm Flat Washers, (4) 8mm Lock Washers and (4) 8mm Hex Nuts, **(Figure 6)**. Do not tighten hardware at this time.
8. Level and adjust the Sidebar properly and tighten all hardware.
9. Repeat **Steps 2—8** for passenger Sidebar installation.
10. Do periodic inspections to the installation to make sure that all hardware is secure and tight.

To protect your investment, wax this product after installing. Regular waxing is recommended to add a protective layer over the finish. Do not use any type of polish or wax that may contain abrasives that could damage the finish.

For stainless steel: Aluminum polish may be used to polish small scratches and scuffs on the finish. Mild soap may be used also to clean the Sidebar.

For gloss black finishes: Mild soap may be used to clean the Sidebar.

Driver/left Side Installation Pictured

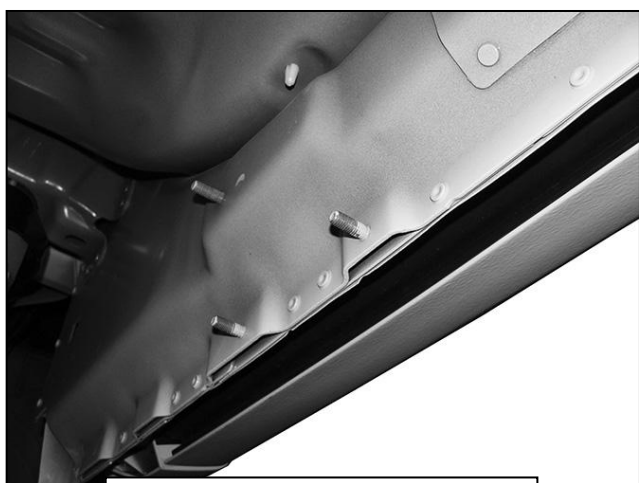

(Fig 1) Locate factory threaded studs. Driver side rear pictured

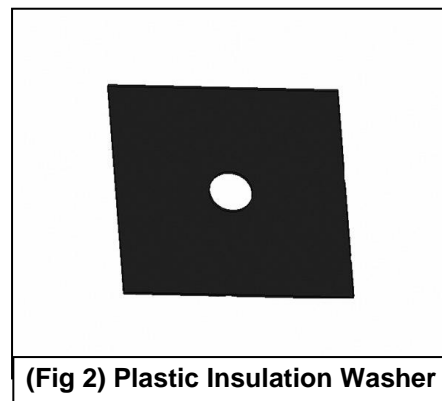

(Fig 2) Plastic Insulation Washer

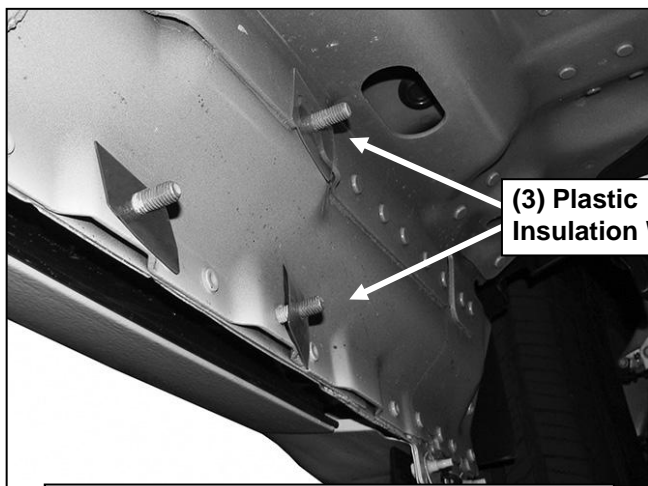

(3) Plastic Insulation Washers

(Fig 3) Thread Plastic Washers onto all mounting studs. Driver side front pictured

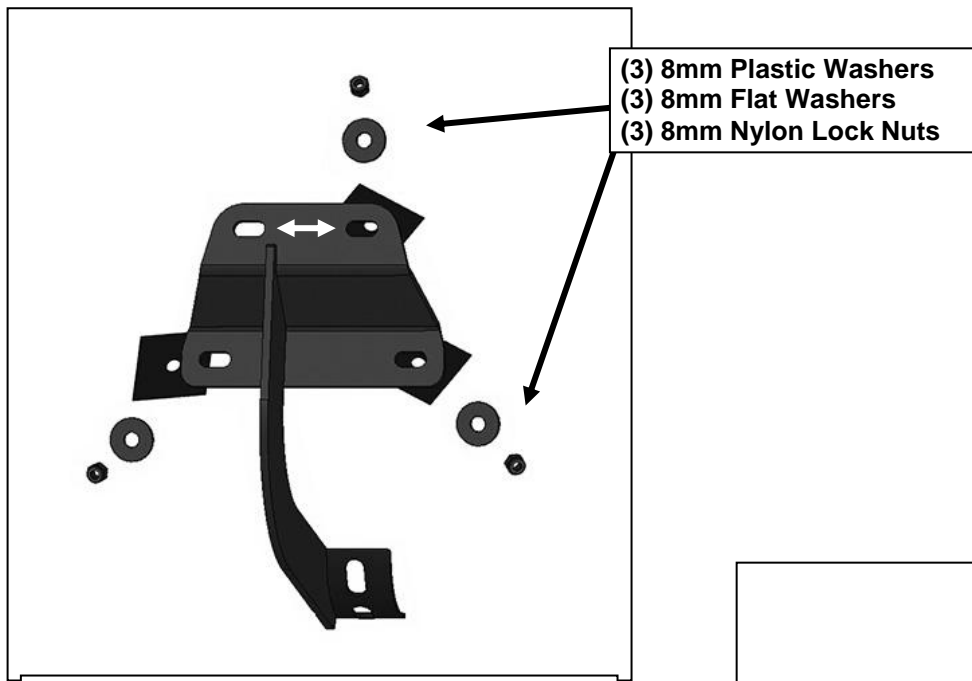

- (3) 8mm Plastic Washers
- (3) 8mm Flat Washers
- (3) 8mm Nylon Lock Nuts

(Fig 4) Typical Bracket installation illustrated



(Fig 5) Slide (2) 8mm T-Bolts into each channel in bottom of Sidebar

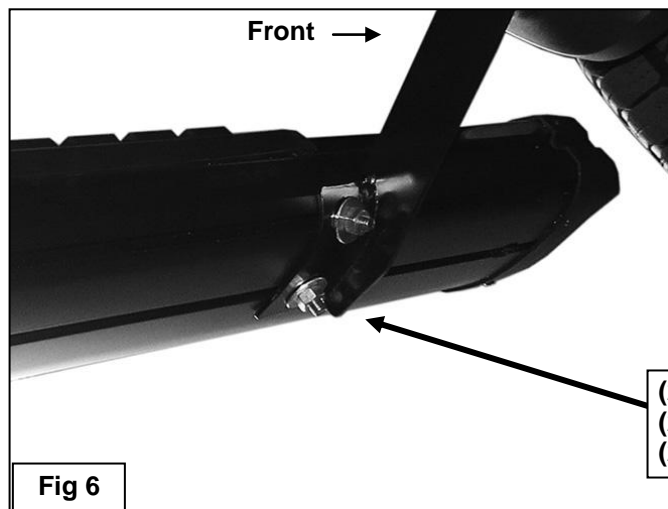

- (2) 8mm x 24mm STD Flat Washers
- (2) 8mm Lock Washers
- (2) 8mm Hex Nuts

Fig 6