

15-18 Ford F150 Super Cab 5.5' & 17-18 F250/350 SUPER DUTY SUPER CAB 6.5FT STANDARD BED

5" Wheel to Wheel Side Bara

PARTS LIST:

1	Driver/left Sidebar	2	10mm x 35mm Bolt Plates
1	Passenger/right Sidebar	4	10mm x 20mm x 2mm Flat Washers
4	Front/Center 5-inch SB Mounting Brackets	4	10mm Lock Washers
1	Driver/left Rear Only Mounting Bracket	4	10mm Hex Nuts
1	Passenger/right Rear Only Mounting Bracket	12	8-1.25 x 25mm Hex Bolts
8	10mm Plastic Washers	24	8mm x 24mm x 2mm Washers
12	8mm Plastic Washers	12	8mm Lock Washers
2	10mm x 40mm T-Bolt Plates	12	8-1.25mm Nylon Lock Nuts

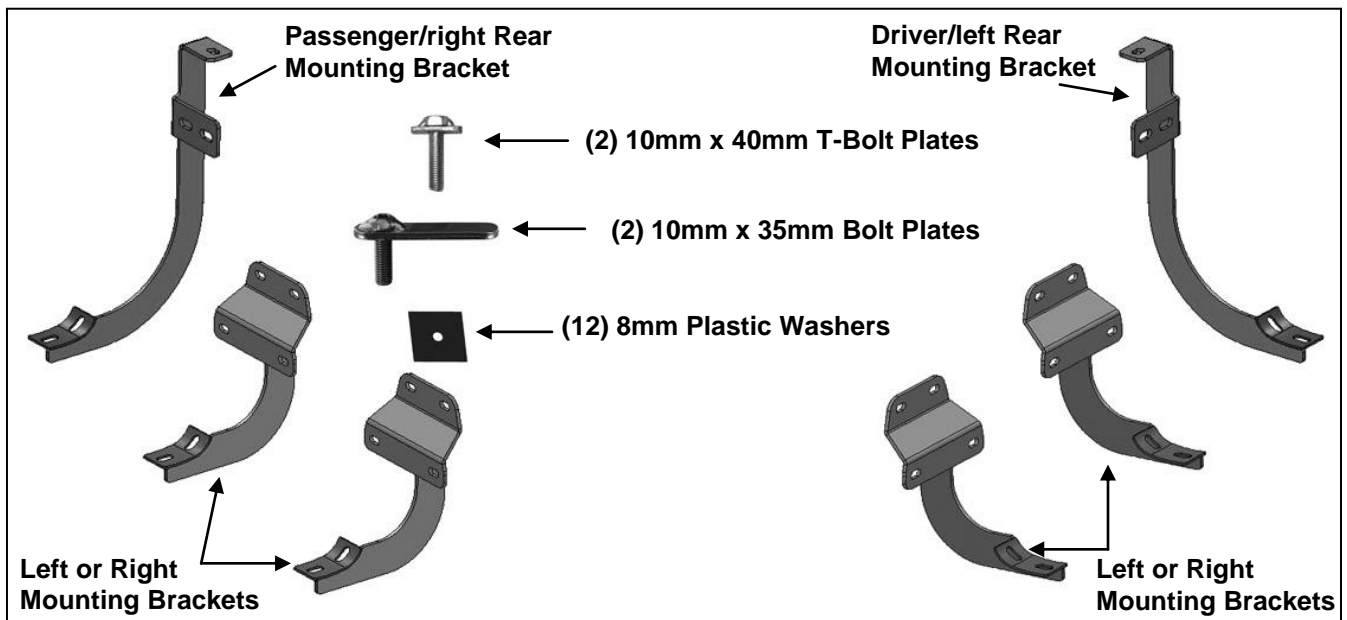

PROCEDURE:

REMOVE CONTENTS FROM BOX. VERIFY ALL PARTS ARE PRESENT. READ INSTRUCTIONS CAREFULLY BEFORE STARTING INSTALLATION. ASSISTANCE IS RECOMMENDED.

1. Start the installation under the driver side of the vehicle. Locate the front factory running board mounting location along the inner side of the body, (**Figure 1**).
2. Slide (1) Plastic Washer over each factory mounting stud in the body panel, (**Figures 2 & 3**). **IMPORTANT:** The Plastic Washers are designed to prevent corrosion between the aluminum body panel and the steel mounting brackets. **Do not install the Brackets without the Plastic Washers.**
3. Select (1) Mounting Bracket. **NOTE:** The (2) Brackets that attach to the (2) factory mounting locations are universal and will fit left or right side. Attach the Mounting Bracket to the (3) factory studs with (3) 8mm Flat Washers and (3) 8mm Nylon Lock Nuts, (**Figures 4 & 5**). Leave hardware loose at this time.
4. Repeat **Steps 1—3** to install the center driver side Bracket, (**Figure 6**).
5. Move to the rear body mount at the back of the cab. Locate the oval hole in the body mount support directly above the square hole in the side of the body panel, (**Figure 7**). Thread (1) 10mm Plastic Washer onto (1) 10mm x 40mm T-Bolt, (**Figure 8**). Thread the Plastic Washer all the way down the threaded end of the T-Bolt. By hand, (pliers can also be used), bend the sides of the Plastic Washer up around the sides of the Bolt Plate, (**Figure 9**).
6. Insert the Bolt Plate and Washer into the oval hole. Once the Bolt Plate is in the hole, thread a second Plastic Washer down until it is tight against the body panel, (**Figure 10**). If necessary, use scissors to

trim plastic washer for easier installation. **IMPORTANT: Do not install the rear Bolt Plates and Brackets without the Plastic Washers.**

7. Next, locate the square hole in the side of the body panel, (**Figure 7**). Select the 10mm x 35mm Bolt Plate and (1) 10mm Plastic Washer, (**Figure 11**). Repeat **Steps 5 & 6** to insert the Bolt Plate and Plastic Washer into the square hole. Trim Plastic Washer as required, (**Figure 12**). Once the Bolt Plate is in the hole, thread a second Plastic Washer down until it is tight against the body panel, (**Figure 13**).
8. Select the driver side rear Bracket. Slide the Bracket over the (2) Bolt Plates. Attach the Bracket to the Bolt Plates with (2) 10mm Flat Washers, (2) 10mm Lock Washers and (2) 10mm Hex Nuts, (**Figure 14**). Leave hardware loose at this time.
9. Select the driver/left Sidebar. Carefully position the Sidebar onto the (3) Mounting Brackets. **IMPORTANT:** Do not slide, (front to back or rotate), the Sidebar on the Brackets or damage to the finish on the Sidebar may result. Attach the Sidebar to the Mounting Brackets with (6) 8mm x 25mm Hex Bolts, (6) 8mm Lock Washers and (6) 8mm Flat Washers, (**Figure 15**). Do not tighten hardware.
10. Level and adjust the Sidebar and tighten all hardware.
11. Repeat **Steps 1—10** to install the passenger/right Sidebar.
12. Do periodic inspections to the installation to make sure that all hardware is secure and tight.

To protect your investment, wax this product after installing. Regular waxing is recommended to add a protective layer over the finish. Do not use any type of polish or wax that may contain abrasives that could damage the finish.

For stainless steel: Aluminum polish may be used to polish small scratches and scuffs on the finish. Mild soap may be used also to clean the Sidebar.

For gloss black finishes: Mild soap may be used to clean the Sidebar.

Driver/left Sidebar Installation Pictured

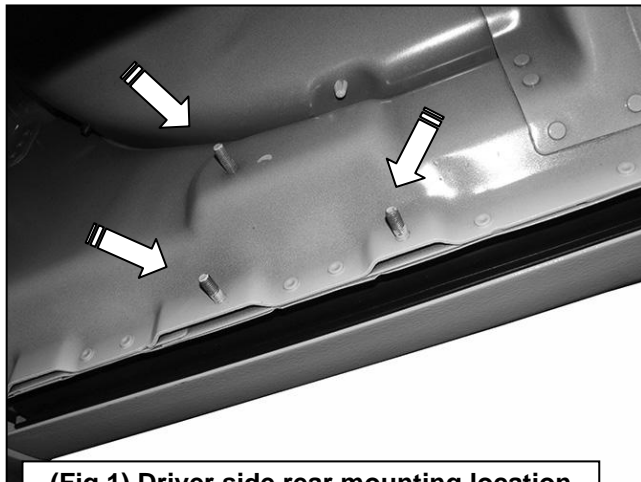

(Fig 1) Driver side rear mounting location

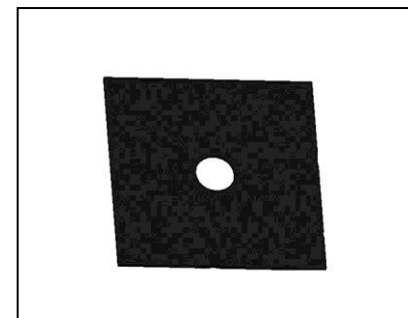

(Fig 2) Plastic Insulation Washer

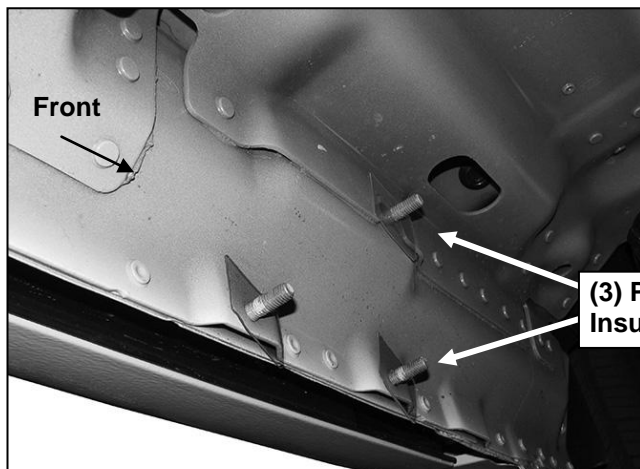

(Fig 3) Thread Plastic Washers onto all mounting studs. Driver side front location pictured

(3) 8mm Plastic Washers
(3) 8mm Flat Washers
(3) 8mm Nylon Lock Nuts

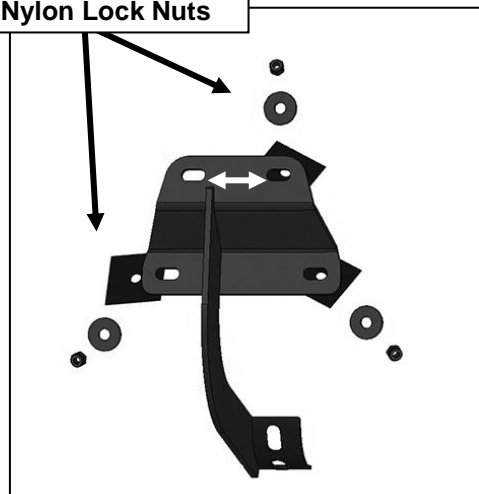

(Fig 4) Typical Bracket installation illustrated

Driver/left Sidebar Installation Pictured

- (3) 8mm Plastic Washers
- (3) 8mm Flat Washers
- (3) 8mm Nylon Lock Nuts

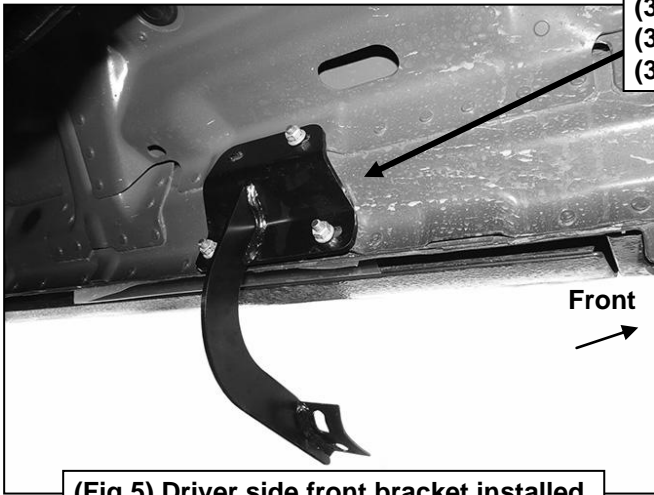

(Fig 5) Driver side front bracket installed

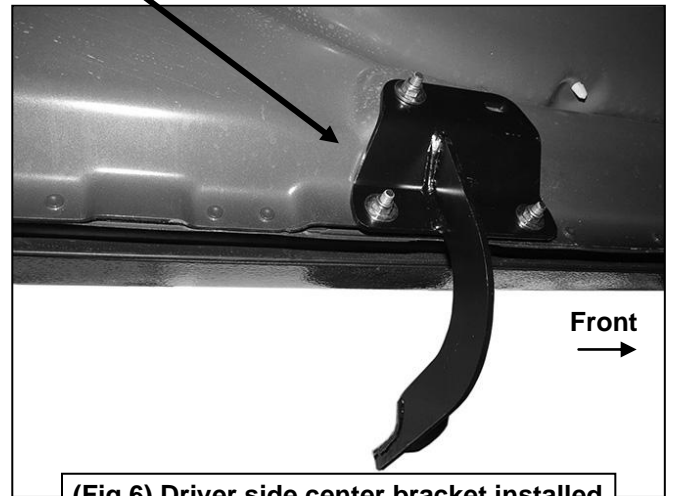

(Fig 6) Driver side center bracket installed



(Fig 7) Driver side rear mounting location



(Fig 8) 10mm T-Bolt with Plastic Washer

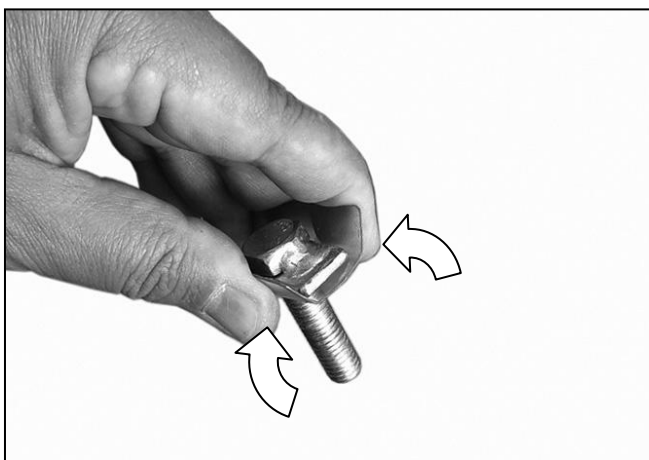

(Fig 9) By hand, bend sides of Plastic Washer up around T-Bolt (pliers may also be used)



(Fig 10) Insert T-Bolt and folded Washer into oval hole. Thread second Plastic Washer onto T-Bolt

Driver/left Sidebar Installation Pictured



(Fig 11) 10mm Bolt Plate with Plastic Washer

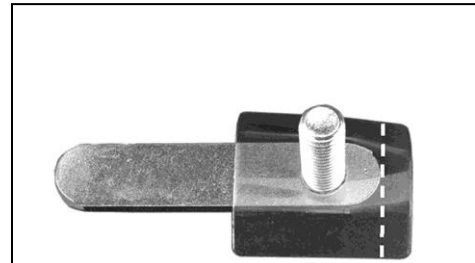

(Fig 12) Bend sides of Plastic Washer up around Bolt Plate. If necessary, use scissors to cut off overhanging plastic. Cut washer on Bolt Plate installation only

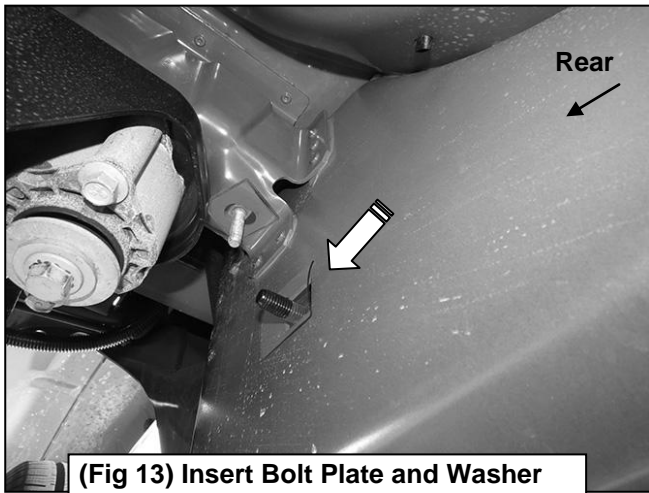

(Fig 13) Insert Bolt Plate and Washer into lower square hole. Thread second Plastic Washer onto Bolt Plate

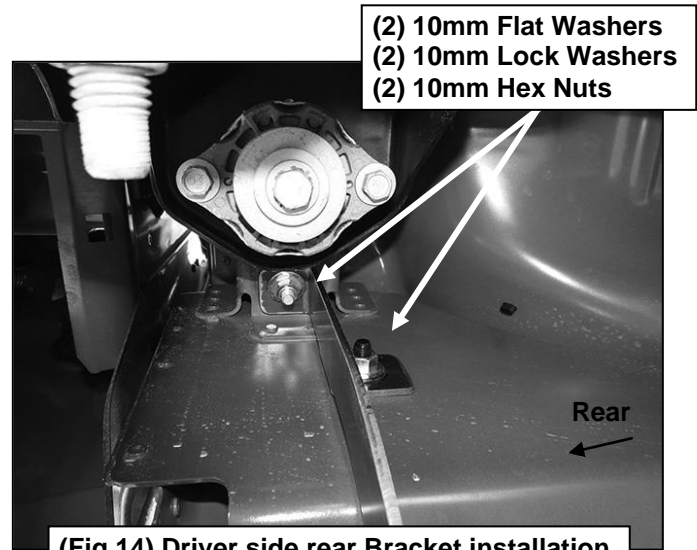

- (2) 10mm Flat Washers
- (2) 10mm Lock Washers
- (2) 10mm Hex Nuts

(Fig 14) Driver side rear Bracket installation



Fig 15

- Attach Sidebar to each Bracket with:
- (2) 8mm x 25mm Hex Bolts
 - (2) 8mm Lock Washers
 - (2) 8mm Flat Washers



Complete Installation