



Installation Instructions

Vehicle Application

Year: **2011-14**
Make: **Ford**
Model: **F150**
Engine: **3.5L EcoBoost**

Tools Required

- 8mm, 10mm, 13mm Wrench & Socket
- Pin Removal Tool or Flat Blade Screwdriver
- 7/16" Wrench and Socket
- 5/16" Nut Driver or Flat Blade Screwdriver
- Phillips Screwdriver
- 1 Set of Torx Wrenches & Allen Wrenches
- 1 Pair of Pliers or similar tool

S&B Filter Maintenance

Cleanable (KF-1058). If the enclosed filter is Red, it came pre-oiled from the factory. Please visit www.sbfilters.com for the exact oil amount required after cleaning.

Disposable (KF-1058D). If the enclosed filter is White, it is a disposable filter and should be discarded once it reaches capacity. This filter (does not require oil). For more info on S&B's disposable filter, visit www.sbfilters.com.

Notes

Kit may not fit with the following Aftermarket Parts installed:

- Body Lift or Lowering Kit
- Custom Hood

CARB Status - Pending

CARB EO#: D-590-12

Legal for use in CA or other states adopting CA emissions standards
See Page 5 for more info.

Before You Start

- Please read the entire product guide before proceeding.
- Ensure all components listed on page 4 are present.
- If you are missing any of the components, call our customer support at (909) 947-0015.
- Do not work on your vehicle while engine is hot.
- Make sure the engine is turned off and the vehicle is in Park or the Parking Brake is set.

1. With the ignition switched off and the parking brake set, disconnect the negative battery cable on the passenger side. **Note: Failure to disconnect the battery may cause the CEL to illuminate upon completion of the installation and subsequent operation. Do not skip this step!**



2. This vehicle is equipped with one of two different sensors depending on which year your vehicle is.

Older Models 2011



Newer Models 2012-14



3. The sensor must be removed from the factory intake tube.

The sensor for the older vehicles requires a Torx wrench to remove the sensor from the tube.



On newer vehicles use a pair of pliers or female Torx to unscrew the bolt and remove the sensor from the tube.



Be careful on the removal of the sensor to not damage the wiring connections on the harness.



4. Once the sensor is removed from the tube it must be removed from the harness also.

(Older Vehicle Sensor) pull the Red tab out and press down on the release button while pulling out.



(Newer Vehicle Sensor) press down on the release button and pull out to remove the sensor from the connector and harness.



5. With the sensor removed loosen all three hose clamps that are on the factory intake tube.



SEE EXPLODED VIEW ON PAGE 6



Installation Instructions (continued)

6. Remove the top tube by pulling out and away from the factory air box.



7. Pull the rest of the factory intake tube out by moving it to the side and lifting up. **Note:** on some vehicles there is a hose from the crank case that also must be removed.

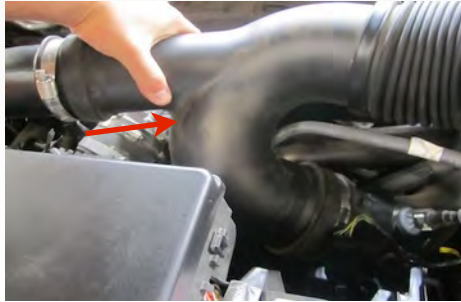

8. Remove the factory air box cover by disconnecting the three metal latches that are on the side of the factory air box.



9. Once all three latches are disconnected lift the cover up and out to the side to remove.



10. Remove the factory air filter.

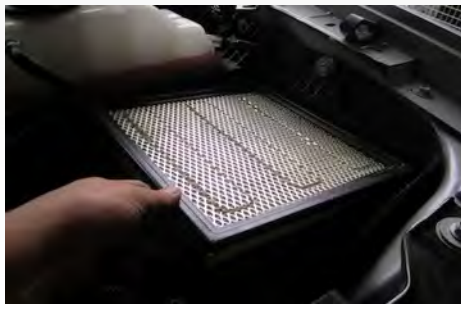

11. Remove the factory air box by removing both bolts and lifting up on the box. The other connections to the box do not need to be removed to gain access to the side inlet.



12. Once access is available to the side inlet remove by pushing down on the tabs. A screw driver may be required to loosen the 2 tabs on top and 1 tab underneath.



13. Install the S&B fender Inlet (X) by pushing in firmly, wait until it snaps into place.

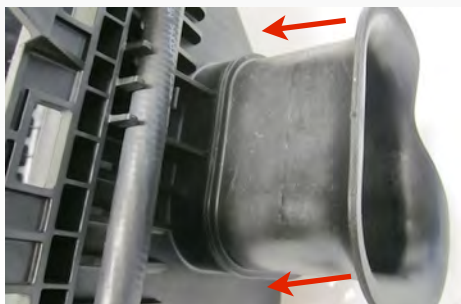

14. After the S&B inlet is installed, lower the factory air box back down and reinstall the factory bolts. Make sure the S&B inlet (X) is pushed through the side skirt.



15. Attach coupler (T) to intake tube (C) using hose clamps (L). Only tighten the hose clamp on the S&B intake tube side while leaving the other hose clamp loose.



16. Attach coupler (S) to intake tube (C) using hose clamps (M). Again only tighten the hose clamp on the tube side while leaving the other hose clamp loose.



17. Attach the hose clamp (O) to the intake rubber cuff (R).



SEE EXPLODED VIEW ON PAGE 6



Installation Instructions (continued)

18. Install the cuff (R) onto the S&B air box cover (B) making sure that the tab on the cuff aligns with the notch on the S&B Air Box Cover.



19. Insert the intake tube assembly into the cuff. Please make sure that the tube is pushed all the way to the stop hump of the tube. This will not be an air tight fit to allow for engine movement.



20. Once the tube is pushed flush against the stop hump of the tube the hose clamp (O) on the cuff can be tightened down.



21. Flip over the assembly and install the S&B air filter (Q) and tighten the hose clamp (N). Position the clamp so that it can be accessed through the lid in the future.



22. Once the filter is installed use the correct adapter plate for the correct model year.

Early Models (U) Newer Models (V)
2011 2012-14



23. Install the adapter plate (U) or (V) and gasket (W) using the two 10-32 screws (G). Please make sure that the arrows are aligned to ensure proper installation.

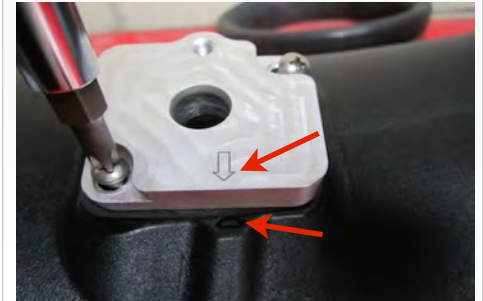

24. Once the adapter plate is connected install the factory sensor to the plate using the provided hardware (J) or (H&I).



25. **Note:** check to see if your vehicle has a hose connected to the crank case from the intake tube. If so connect the Hose Barb (D) to the crankcase inlet on the S&B intake tube. If not install the Hex Plug Socket (K) into the crankcase inlet using the correct Allen wrench (use Teflon tape around which ever fitting is used).

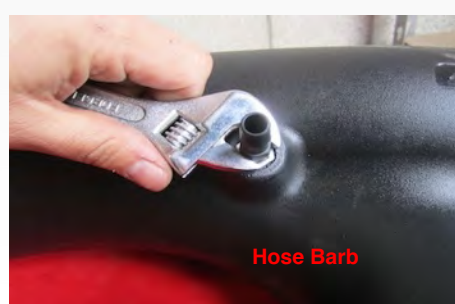

26. The S&B intake is now ready for installation.



27. Place the whole intake assembly and lower it down into the stock intake box. Please make sure that the tabs on the S&B air box cover fit correctly into slots on the factory box on the right hand side. Once the tabs are in the slots lower the whole intake assembly into place.

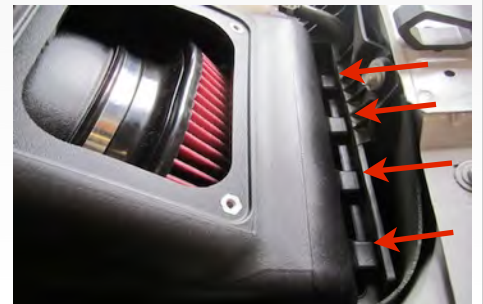

SEE EXPLODED VIEW ON PAGE 6



Installation Instructions (continued)

28. Lower the complete assembly and make sure the S&B Air Box Cover (B) sits inside the factory air box slots. Proper installation into the slots will reduce movement.



29. Attach the bottom tube to the bottom turbo inlet and push in completely. After the tube is pushed in all the way tighten the hose clamp.



30. Attach the top turbo inlet tube completely and again tighten the hose clamp.



31. After all the hose clamps are tightened remember to reconnect the three latches on the side of the intake box.

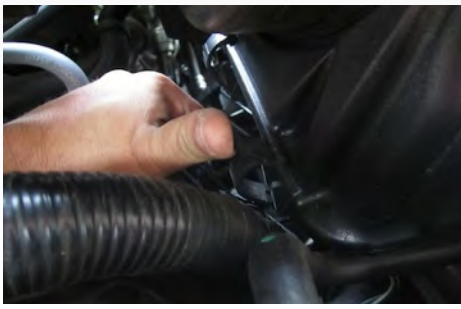

32. Plug the harness into the sensor under the intake tube. Press in firmly till it locks.
Note: older vehicles must also press in the Red lock tab after the harness is connected.



33. **Note:** if your vehicle has a hose that connects from the intake tube to the crank case remember to connect the hose firmly to the S&B hose fitting (D).

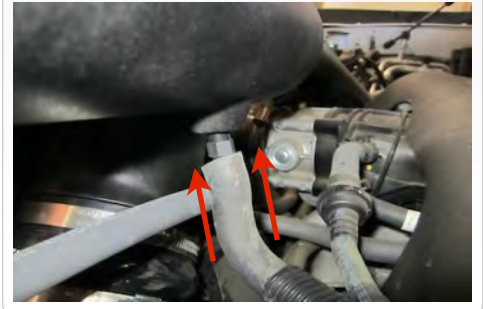

34. Fasten the air box lid (P) using the provided hardware (E & F).



35. Reconnect the battery. Inspect your installation, make sure the kit is properly positioned and all fasteners are secure.



36. Affix the CARB and ID label near the intake kit. Keep all stock parts in case you would ever need to reinstall the stock intake. The installation is now complete.



Related Items to Your Purchase

- Replacement Air Filter (Oiled) (S&B P/N: KF-1058)
- Replacement Air Filter (Dry) (S&B P/N: KF-1058D)
- Air Filter Wrap (S&B P/N: WF-1058)

Testing and Maintenance

- Engage parking brake and start your engine. Listen for abnormal noises. If an air leak is detected, re-inspect hoses and connections as they may need to be repositioned and tightened.
- S&B FILTERS recommends that you keep your OE intake system in the event it is required in the future.
- In order to maintain your warranty, all connections and components must be checked periodically for alignment and for proper tension on all connections. Failure to do so may void your warranty.
- Use only S&B FILTERS cleaning and oil products to service your filter. Using any other brand oil and or cleaners on your S&B air filter may void your warranty. See www.sbfilters.com for complete warranty information.

Precision II Filter Cleaning & Oiling



Order online today at www.sbfilters.com or through your local S&B distributor.
Part #: 88-0008

SEE EXPLODED VIEW ON PAGE 6



Installation Instructions (continued)

Notes:

Warning!

If your vehicle has a Vehicle Emission Control Information decal affixed to the factory airbox, a new replacement label must be obtained and installed in a readily visible position in the engine compartment in order to remain CARB compliant. Failure to do so will prevent the vehicle from passing a smog check. Replacement labels can be ordered from your local dealership. Regulations state that the VECI label shall not be affixed to any equipment which is easily detached from the vehicle. Label placement, under the hood

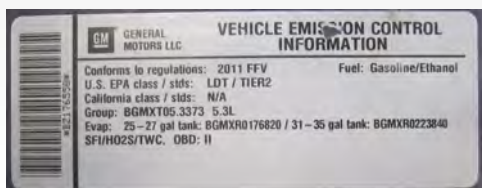

Emissions Standard

The California Air Resource Board (CARB) requires that an E.O. identification label be applied to the vehicle in order to pass a smog check inspection when a Performance Intake Kit has been installed. You must place the E.O. label provided on or near the intake kit after installation so that a smog check technician can easily verify the E.O. number. As of April 2009, S&B has never had a product where CARB denied an exemption request; however, the exemption process with CARB can take as long as 18 months. Check the status of the exemption process by looking up a specific part number at www.sbfilters.com. The CARB Exemption number and/or status is listed under the Product Details section for each part number. If the status shows as "Pending," CARB has yet to issue an exemption. Products that have not been issued an EO number are street legal in most states, but may not be used on emission controlled vehicles in the state of California and are for off road use only. If you purchased your kit from S&B Filters directly, we will automatically mail you your Exemption Sticker when it is issued to us. If you purchased your kit from an authorized S&B Filters Dealer, log onto our web site and register to receive your Exemption Sticker.

SEE EXPLODED VIEW ON PAGE 6



Exploded View

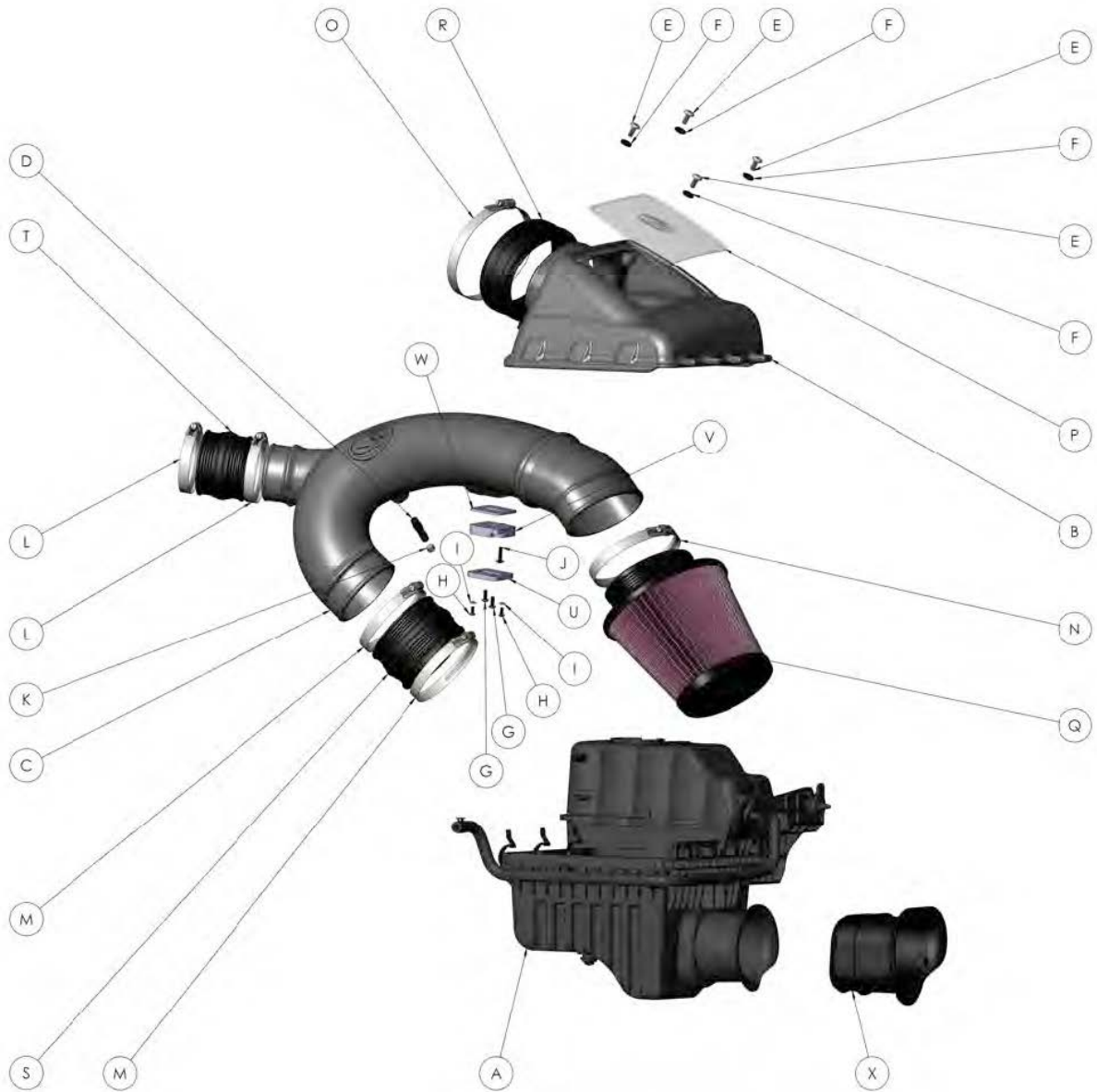

ITEM	QTY.	DESCRIPTION	P/N
A	1	Factory Intake Box	-----
B	1	Air Box Cover	AL1217-00
C	1	Intake Tube	AL1216-00
D	1	Hose Barb 3/8" x 1/8" NPT	AL1643-00
E	4	Truss Head 1/4-20 x 5/8"	AL1569-00
F	4	Sealing Washer	AL1571-00
G	2	S.S. Pan Head 10-32 x 1/2"	AL1640-00
H	2	S.S. Pan Head 8-32 x 3/8"	AL1639-00
I	2	Rubber Washer	AL1200-00
J	1	S.S. Truss Head 10-32 x 3/4"	AL1641-00
K	1	Hex Socket Plug 1/8" NPT	AL1398-00
L	2	Hose Clamp #52	AG1007-00
M	2	Hose Clamp #72	AG1009-00
N	1	Filter Hose Clamp	-----

ITEM	QTY.	DESCRIPTION	P/N
O	1	Hose Clamp #104	AG1012-00
P	1	Lid	AL1607-00
Q	1	S&B Filter	KF-1058
R	1	Rubber Cuff	AL1604C-00
S	1	Straight Coupler	AL1333C-00
T	1	Hump Coupler	AL1601C-00
U	1	Adapter Plate (Early Models)	AL1209-00
V	1	Adapter Plate (Late Models)	AL1605-00
W	1	Adapter Plate Gasket	AL1637-00
X	1	Fender Inlet	AL1635C-00

AM0202-00 Rev. F 07/17/2017

Warranty

Visit www.sbfilters.com for complete warranty information.