

LD2 FRONT BUMPER SKID PLATE
09-14 FORD F150

PARTS LIST:

1	LD2 Front Skid Plate
2	5mm Spacers
2	8mm Clip Nuts
2	8mm x 35mm Button Head Bolts
4	8mm x 25mm Button Head Bolts
6	8mm x 24mm x 2mm Flat Washers
6	8mm Lock Washer
1	5mm Wrench

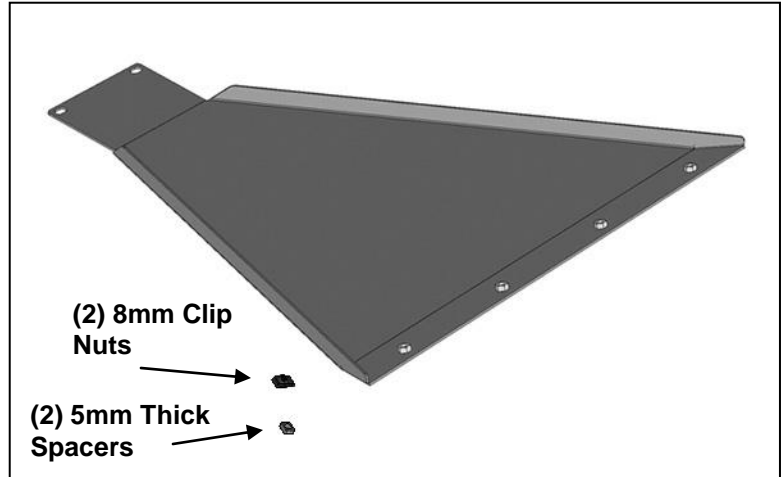

PROCEDURE:

REMOVE CONTENTS FROM BOX. VERIFY ALL PARTS ARE PRESENT. READ INSTRUCTIONS CAREFULLY BEFORE STARTING INSTALLATION. ASSISTANCE IS RECOMMENDED. CUTTING MAY BE REQUIRED.

1. Carefully unwrap the Skid Plate.
2. Determine type of factory skid plate before proceeding.

Models with “flat style” skid plate, (Figure 1).

- a. Locate the mounting holes in the bottom of the crossmember, **(Figure 2)**.
- b. Insert (1) 8mm Clip Nut into the center hole, slide the Clip outward with the threaded nut inside the crossmember. Line up the threaded nut on the Clip Nut with the smaller round hole, **(Figure 3)**. Repeat to install the 2nd Clip Nut.
- c. Insert the LD-2 Skid Plate between the factory skid plate and the bottom of the crossmember.
- d. Place the front of the LD-2 Skid Plate on the back of the Bumper.
- e. Attach the Skid Plate to the Bumper with the included (4) 8mm x 25mm Button Head Bolts, (4) 8mm Lock Washers and (4) 8mm Flat Washers, **(Figures 7 & 8)**.
- f. Attach the Skid Plate to the (2) Clip Nuts with the included (2) 8mm x 35mm Button Head Bolts, (2) 8mm Lock Washers and (2) 8mm Flat Washers, **(Figure 4)**.
- g. Skip to **Step 3**.

Models with formed style skid plate.

- a. Remove the (2) center bolts attaching the skid plate to the bottom of the crossmember, **(Figure 5)**.
- b. Attach the Skid Plate to the back of the Bumper with the included (4) 8mm x 25mm Button Head Bolts, (4) 8mm Lock Washers and (4) 8mm Flat Washers, **(Figures 7 & 8)**.
- c. Attach the Skid Plate over the factory formed skid plate with the included (2) 5mm Spacers, (2) 8mm x 35mm Button Head Bolts, (2) 8mm Lock Washers and (2) 8mm Flat Washers, **(Figure 6)**.
NOTE: Place the 5mm Spacers between the 8mm Flat Washers and the factory formed skid plate.

3. Level and adjust the Skid Plate and fully tighten all hardware, **(Figure 8)**.
4. Do periodic inspections to the installation to make sure that all hardware is secure and tight.

To protect your investment, Do not use any type of polish or wax that may contain abrasives that could damage the finish. Mild soap may be used to clean the Skid Plate.

LD2 FRONT BUMPER SKID PLATE
09-14 FORD F150



(Fig 1) Example of “flat style” factory skid plate. Insert end of LD-2 Skid Plate between factory skid plate and crossmember (arrow)



(Fig 2) Locate mounting location on bottom of crossmember

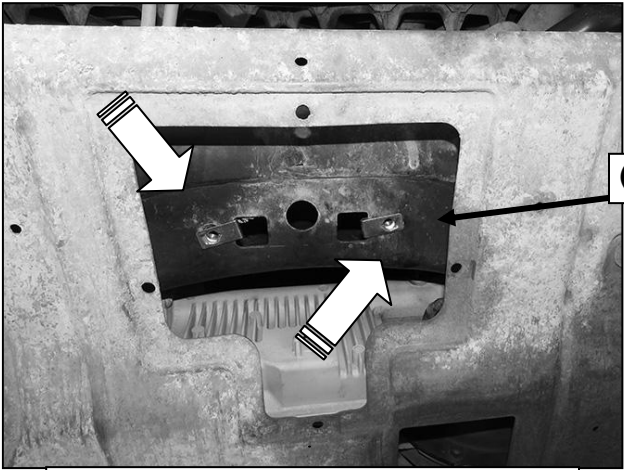

(Fig 3) Insert Clip Nuts into square hole and over smaller round hole (arrows)

(2) 8mm Clip Nuts

- (2) 8mm x 35mm Button Head Bolts**
- (2) 8mm Lock Washers**
- (2) 8mm Flat Washers**
- (2) 8mm Clip Nuts**

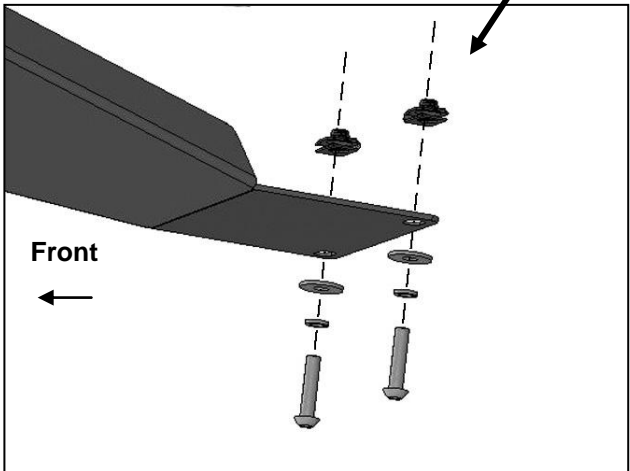

(Fig 4) Attach back end of Skid Plate to Clip Nuts

**LD2 FRONT BUMPER SKID PLATE
09-14 FORD F150**

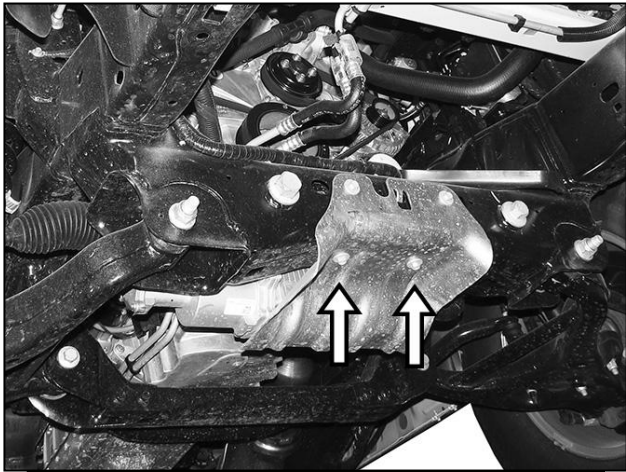

(Fig 5) Example of “formed style” factory skid plate bolted to crossmember. Remove (2) factory hex bolts (arrows)

- (2) 8mm x 35mm Button Head Bolts
- (2) 8mm Lock Washers
- (2) 8mm Flat Washers

Insert 5mm Spacers between factory formed skid plate and LD-2 Skid Plate

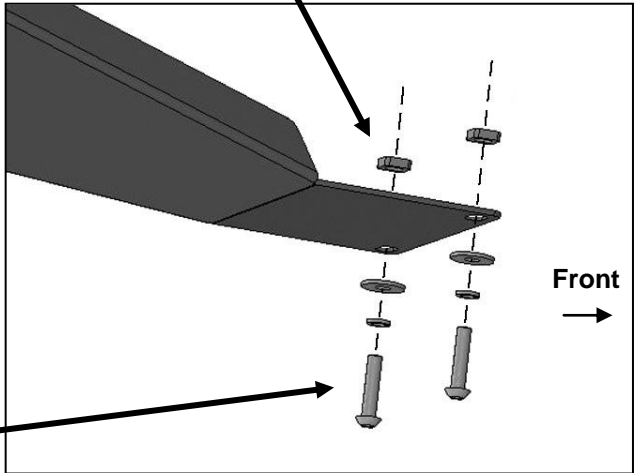

(Fig 6) Use longer (2) 8mm x 35mm Button Head Bolts (2) 8mm Lock washers and (2) 8mm Flat Washers to attach LD-2 Skid Plate to factory formed skid plate and crossmember

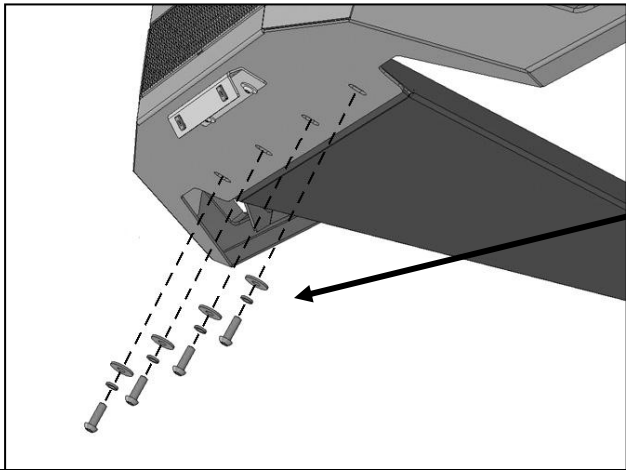

- (4) 8mm x 25mm Button Head Bolts
- (4) 8mm Lock Washers
- (4) 8mm Flat Washers

(Fig 7) Attach Skid Plate to back of LD-2 Bumper



(Fig 8) Skid Plate fully installed on model with “flat style” factory skid plate