

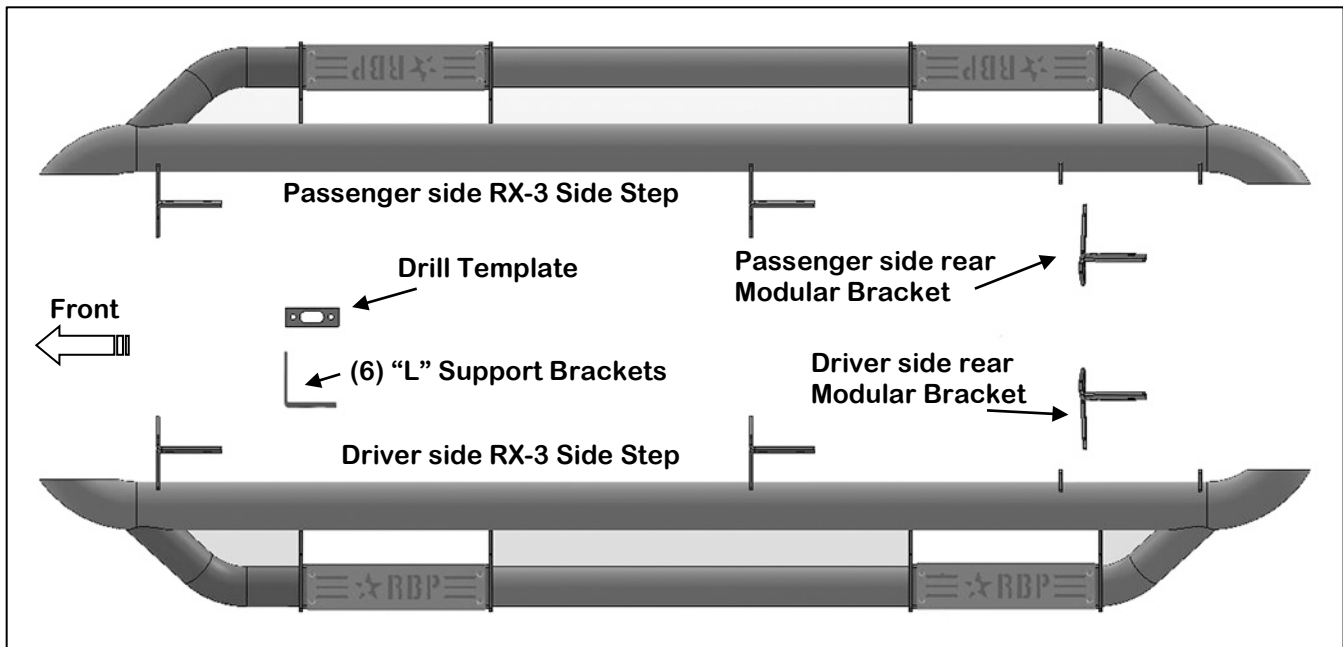

**RBP-1215B-RX3 2002-2017 DODGE RAM 15 - 3500 QUAD CAB RX3**



HARDWARE INCLUDED			
1	Driver Side RX-3 Side Step	12	10-1.5mm Hex Threaded Inserts
1	Passenger Side RX-3 Side Step	13	10-1.5mm x 35mm Hex Bolts
1	Driver Side Modular Rear Bracket	12	10mm Lock Washers
1	Passenger Side Modular Rear Bracket	13	10mm x 20mm OD x 2mm Flat Washers
6	"L" Support Brackets	16	8-1.25 x 25mm Hex Bolt
1	Hole Template Plate	18	8mm x 22mm OD x 2mm STD Flat Washer
1	10mm Insert Tool	8	8mm x 16mm OD x 1.6mm Small Flat Washer
12	10-1.5mm Clip-On Nuts	16	8-1.25mm Nylon Lock Nuts
RECOMMENDED TOOLS			
2	13mm Wrenches	1	3/8" Torque Wrench
	3/8" Ratchet with 3" and/or 6" Extension	1	Electric Drill
1	13mm Socket	1	3/8" Drill Bit
1	16mm Socket	1	7/16" Drill Bit

**STEP 1 -** Remove any old steps and hardware from the truck.

**STEP 2 -** Select the driver side step, (use illustration on page 1), and driver side rear Modular Bracket. Attach the Modular Bracket to the appropriate mounting flange toward the back of the step with (2) 8mm Hex Bolts, (4) 8mm x 16mm Small Flat Washers and (2) 8mm Nylon Lock nuts, (Figures 1, 2, 14 & 19).

**02-08 1500, 03-09 25-3500:**

Attach the rear modular bracket to the back of the forward mounting tab on the step, (Figure 1). Snug but do not fully tighten hardware at this time.

**09-14 1500, 10-14 25-3500:**

Attach the rear modular bracket to the back of the rear mounting tab on the step, (Figure 2). Snug but do not fully tighten hardware at this time.

**STEP 3 -** Start installation towards the front of the driver's side of the vehicle. Locate the factory mounting holes in the side of the inner body panel, (Figures 3 & 9). NOTE: Remove any plugs or sealing tape as required, (Figure 4).

**STEP 4 -** Determine the correct procedure for your vehicle. NOTE: On 02-08 models, there are several mounting holes to choose from in the body panel, (Figure 3). Temporarily hold the Side Step assembly up in place and mark the locations to identify the correct mounting holes required for installation.

**02-08 1500, 03-09 25-3500:**

Locate the 2nd oval hole from the front, (Figure 4). Select the drill template from the bracket kit. Line up the drill template with the correct oval hole, (Figure 5).

Mark the smaller holes in the template onto each side of the oval hole, (Figure 6). Use a 7/16" drill bit to drill the (2) holes as marked, (Figure 7).

Select (2) 10mm U-Nuts. Slide the U-Nuts into the oval hole and over the (2) drilled holes, (Figure 8). Repeat this Step for the center and rear bracket mounting locations.

**09-14 1500, 10-14 25-3500:**

Locate the factory front mounting location along the inner body panel, (Figures 9 & 10).

Select (1) Hex Threaded Insert and (1) Insert Tool, (Figure 11). Insert (1) 10mm Hex Bolt and (1) 10mm Flat Washer into the tool. Thread (1) Insert onto the Hex Bolt.

Push the threaded insert into either hex shaped hole below the oval hole. Firmly hold the handle on the tool and tighten the hex bolt to expand the insert in the hex shaped hole, (Figure 12). Once fully installed, remove the hex bolt and tool from the insert. Repeat this step to install all (6) required threaded inserts along the driver side body panel.

**STEP 5 -** With assistance, hold the driver side step assembly up in position against the mounting locations.

Attach the brackets on the step to the (3) locations with (6) 10mm Hex Bolts, (6) 10mm Lock Washers and (6) 10mm Flat Washers, (Figures 13 & 14). Snug but do not fully tighten hardware.

**STEP 6 -** Select (1) "L" Support Bracket. Attach the support bracket to the back of the front bracket with (1) 8mm Hex Bolt, (2) 8mm x 22mm STD Flat Washers and (1) 8mm Nylon Lock nut. Leave loose at this time.

NOTE: Attach support bracket with leg toward the rear of the vehicle.

**02-08 models,** use the bottom hole in the mounting bracket, (Figure 15).

**09-14 models,** use the top hole in the mounting bracket

**STEP 7 -** Hold the Support Bracket up to the back of the pinch weld and tighten the 8mm hex bolt.

**02-12 models without holes in the pinch weld:**

Use the support bracket for a template and mark the hole location onto the back of the pinch weld. Move the support bracket out of the way. Use a 3/8" drill bit to drill a hole through the pinch weld, (Figure 15).

**12-14 models with factory holes in the pinch weld:** Proceed to Step 8, (Figures 17—19).

**STEP 8 -** Line up the "L" Support Bracket with the hole in the pinch weld. Attach the bracket to the pinch weld with (1) 8mm Hex Bolt, (2) 8mm x 22mm STD Flat Washers and (1) 8mm Nylon Lock nut, (Figures 16—19). Leave hardware loose at this time.

**STEP 9** - Repeat **Steps 6—8** to attach the center and rear support brackets to the pinch weld.

**STEP 10** - Align and adjust the step to the side of the vehicle. Once properly adjusted, tighten all hardware. Tighten the 8mm hardware to 18-20ft-lbs and the 10mm hardware to 35-40ft-lbs.

**STEP 11** - Repeat the above steps for the passenger side installation.

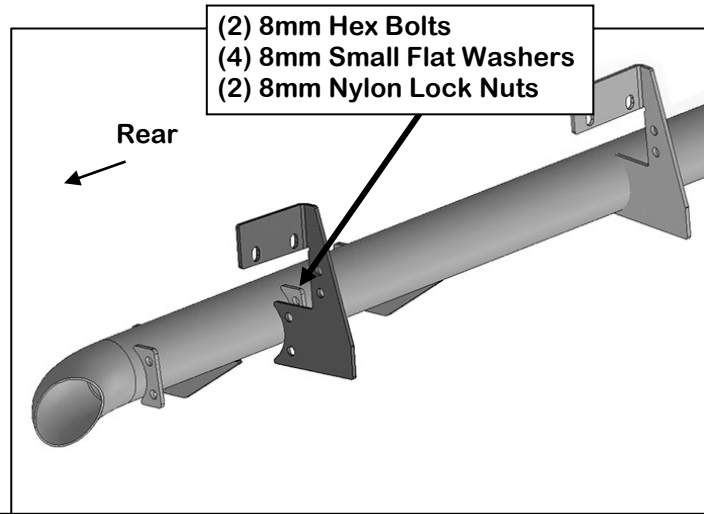

(Fig 1) 02-08 driver side modular bracket installation

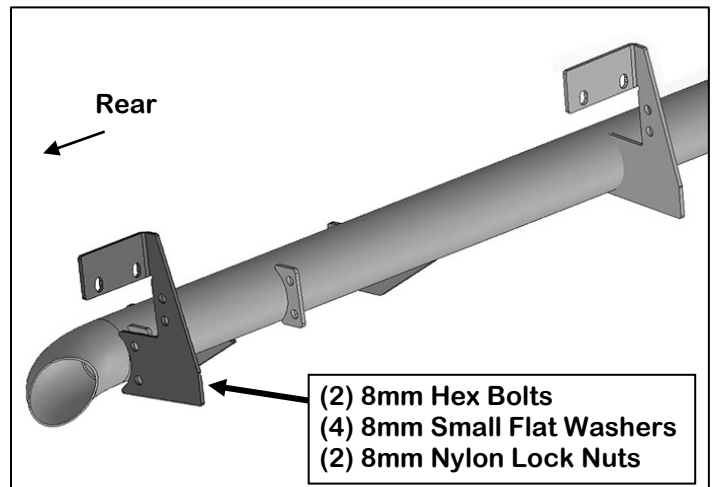

(Fig 2) 09-14 driver side modular bracket installation

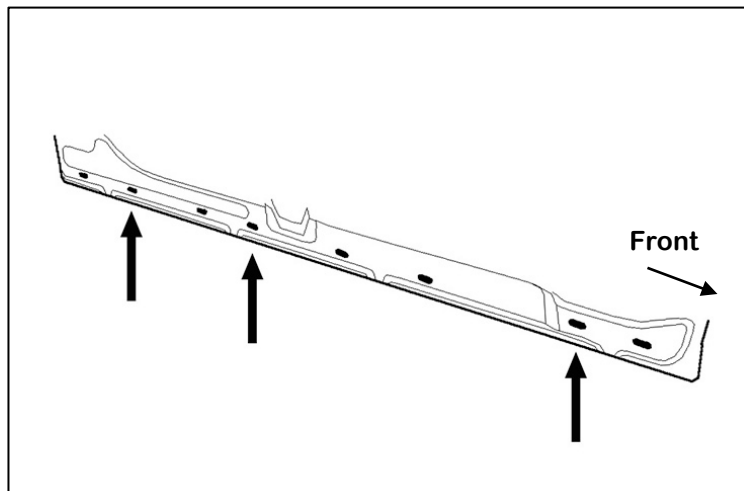

(Fig 3) 02-08 driver side mounting locations illustrated

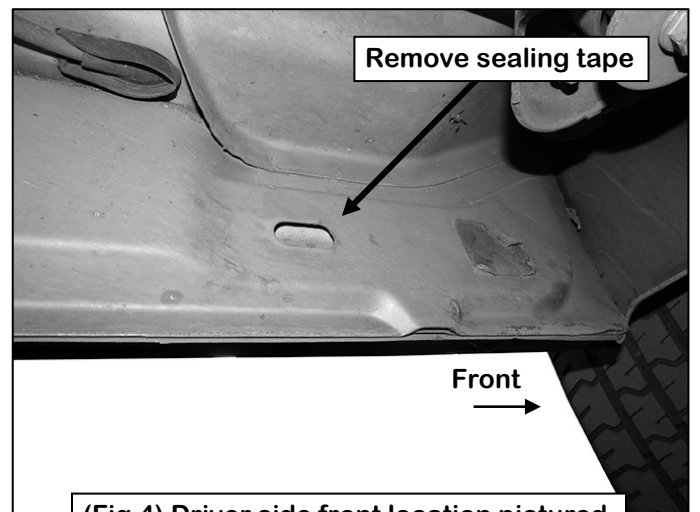

(Fig 4) Driver side front location pictured

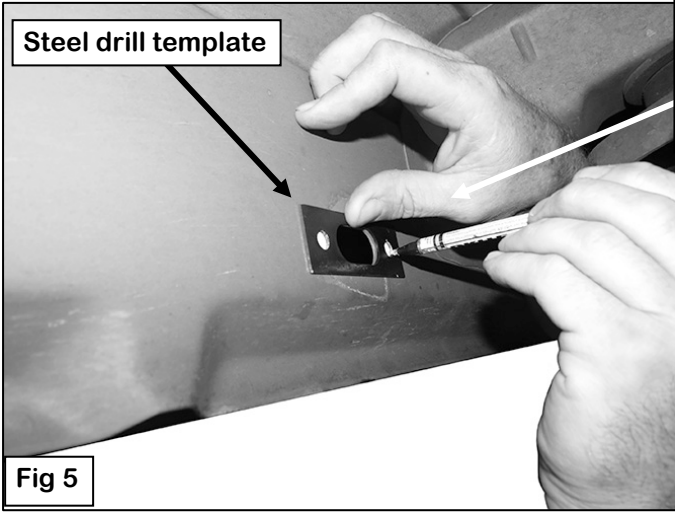

Line up oval hole in body panel with oval hole in template. Mark both outer hole locations onto body panel

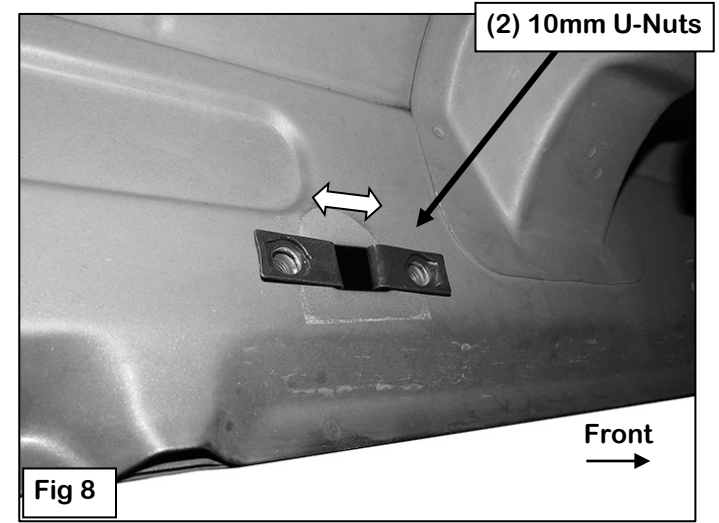
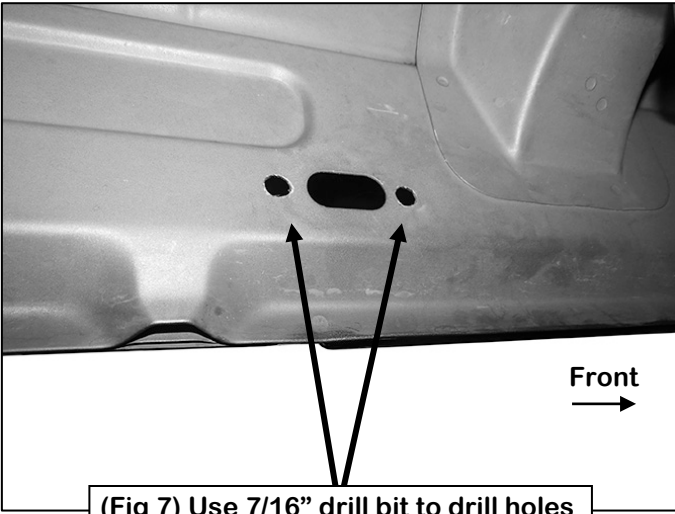
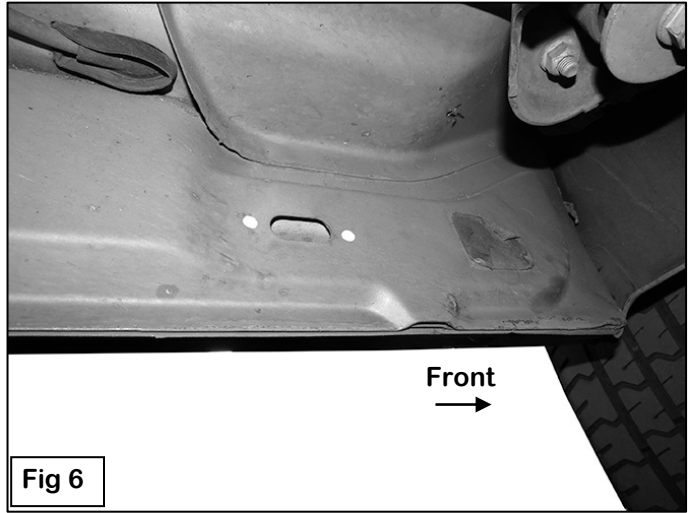

Slide the U-Nut into the oval hole. Line up nut with drilled hole

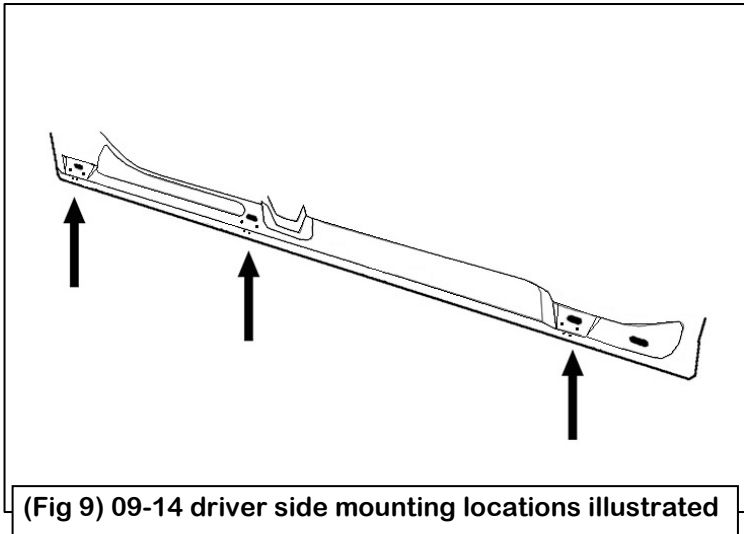

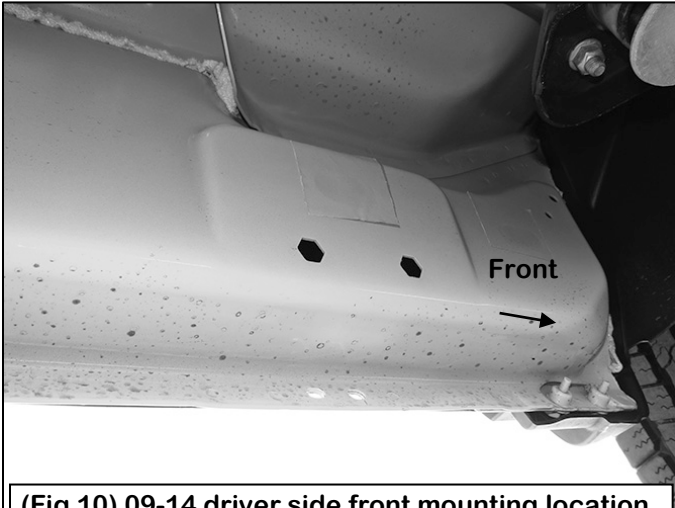

(Fig 10) 09-14 driver side front mounting location

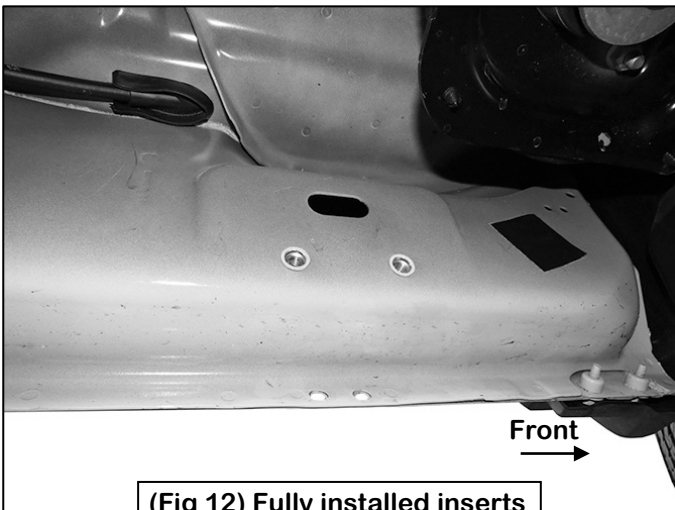

(Fig 12) Fully installed inserts

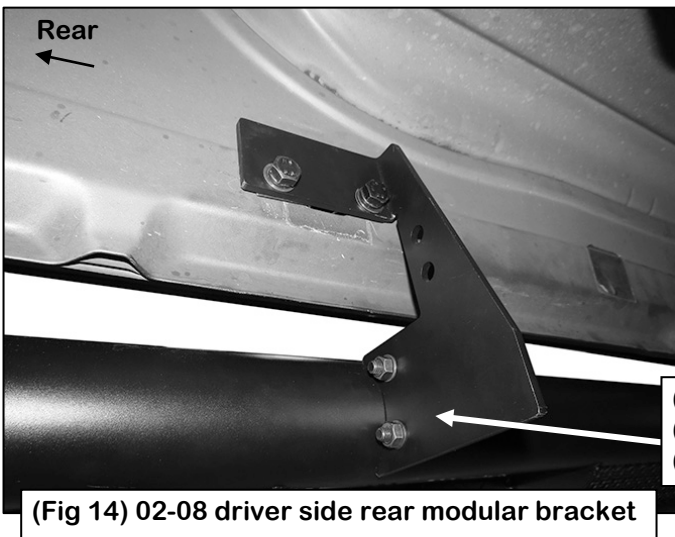

(Fig 14) 02-08 driver side rear modular bracket

- (2) 8mm Hex Bolts
- (4) 8mm Small Flat Washers
- (2) 8mm Nylon Lock Nuts

- (1) 10mm Hex Bolt
- (1) 10mm Flat Washer
- (1) 10mm Hex Threaded Insert



(Fig 11) 10mm insert tool and hex insert

Assemble tool as pictured above, (Fig 11). Hold insert in place against body panel by firmly grasping the handle on the tool. Turn the hex bolt (tighten) with wrench to expand insert in body panel. Once Metal Insert is fully compressed, remove the bolt and tool from Metal Insert. **WARNING:** Do not over-tighten or damage to the insert may result.

- (2) 10mm Hex Bolts
- (2) 10mm Lock Washers
- (2) 10mm Flat Washers

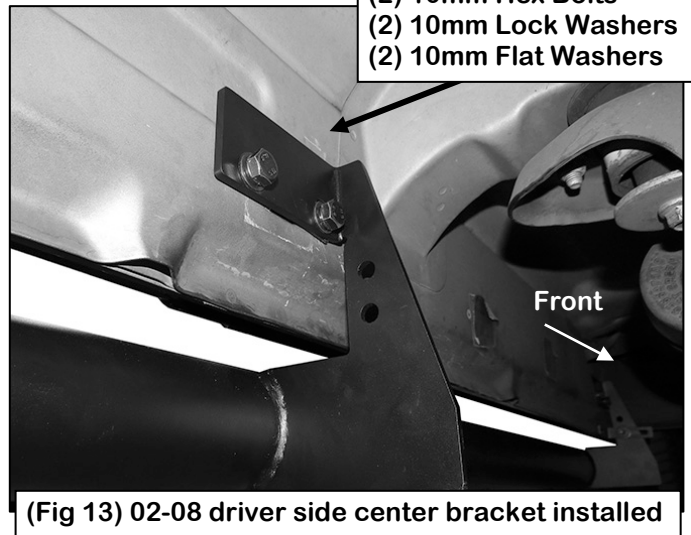

(Fig 13) 02-08 driver side center bracket installed

Mark to drill 3/8" hole through pinch weld

