

**PART# R102597-B R102598-B**

**PARTS LIST:**

1	Driver/Left Sidebar	4	1/2" x 2" Hex Head Bolts
1	Passenger/Right Sidebar	4	1/2" Lock Washers
2	Front Mounting Brackets	4	1/2" ID x 1 1/2" OD x 1/8" Flat Washers
2	Rear Mounting Brackets	4	12mm Lock Washers
1	Driver Side Front Support Bracket	4	12mm x 32mm x 3mm Flat Washers
1	Passenger Side Front Support Bracket	8	10-1.50mm x 35mm Bolt Plates
1	Driver Side Rear Support Bracket (long)	8	10mm Plastic Retainers
1	Passenger Side Rear Support Bracket (long)	8	10mm Lock Washers
4	12-1.75mm x 120mm Gr. 10.9 Hex Bolts	8	10mm ID x 27mm OD x 3mm Flat Washers
4	13mm ID x 68mm OD x 5mm Large Flat Washers	8	10mm Hex Nuts

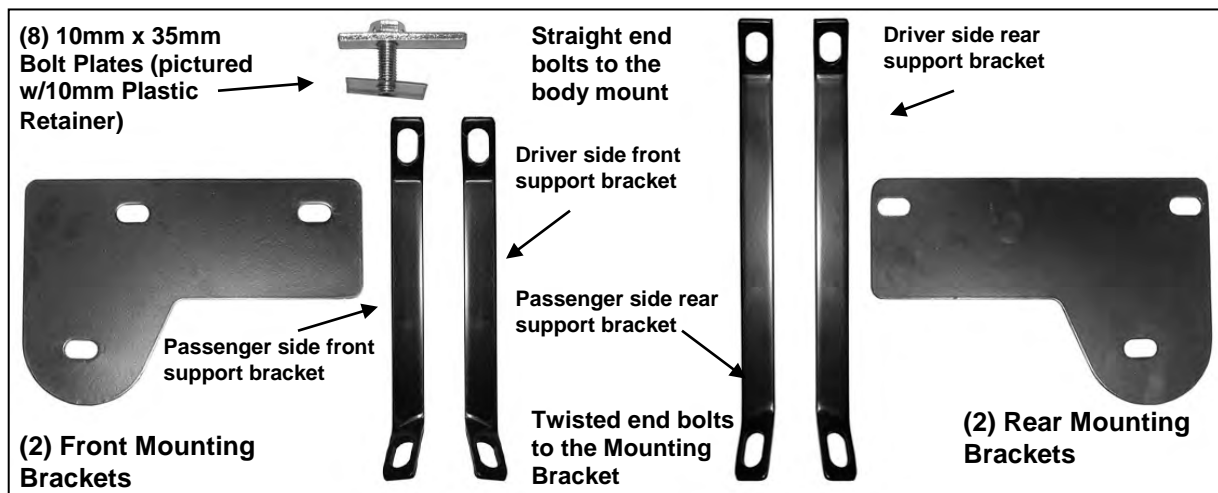

**PROCEDURE:**

- REMOVE CONTENTS FROM BOX. VERIFY ALL PARTS ARE PRESENT. READ INSTRUCTIONS CAREFULLY BEFORE STARTING INSTALLATION.**
- From underside of vehicle remove the sealing tape covering the factory holes on the passenger side inner rocker panel, **(Figure 1)**. These are located by the front and rear tire.
- Thread a Plastic Retainer partially (half way) onto a Bolt Plate, **(Figure 2A)**. Insert the Bolt Plate into the factory slot and twist Bolt Plate to a 45° angle across the opening, **(Figure 2B)**. Once the Bolt Plate is properly installed, hold the threaded end with one hand and tighten the Plastic Retainer against the inner body panel, **Figure 2C)**. **IMPORTANT:** The Plastic Retainer is designed to prevent the Bolt Plate from falling into the body cavity and to aid Mounting Bracket installation.
- Repeat Step 3 remaining Bolt Plate installation.
- Select a front Mounting Bracket and position it onto the previously installed Bolt Plates. Secure it with (2) 10mm Flat Washers, (2) 10mm Lock Washers and (2) 10mm Hex Nuts, **(Figure 3)**.
- Remove the factory front body mount bolt. Select the passenger front Support Bracket and place the straight bend against body mount. Partially hang Support Bracket with factory body mount bolt **(Figures 4A, 4B & 5)**. **NOTE:** The twisted end on the Support Bracket mounts to the Mounting Bracket.

**IMPORTANT!** Depending on model year, the factory body mount bolt may be too short for proper Support Bracket installation or the factory flat washer may not be removable. If necessary, replace the factory body mount bolts and washers with the supplied 12mm x 120mm Hex Bolts, 13mm x 68mm Large Flat Washers, 12mm x 32mm Flat Washers and 12mm Lock Washers. See Page 3, **(Figure 4B)**, for an example and more information. It is the installer's responsibility to determine the correct hardware for proper installation.

- Repeat steps 2-6 for rear Mounting Bracket installation.

8. Line up slot in the Support Bracket with the slot in the Mounting Bracket. Position the front of the passenger Sidebar up to the front Mounting Bracket. Secure the Support Bracket and Sidebar to the Mounting Bracket with (1) 1/2" x 2" Hex Bolt, (1) 1/2" Lock Washer and (1) 1/2" Flat Washer, (**Figure 4 & 5**). Do not tighten at this time. Repeat this step for rear Sidebar mounting.
9. Level and align Sidebar properly and tighten all hardware.
10. Repeat steps 2-9 for driver Sidebar installation.
11. Do periodic inspections to the installation to make sure all hardware is secure and tight.

**To protect your investment**, wax this product after installing. Regular waxing is recommended to add a protective layer over the finish. Do not use any type of polish or wax that may contain abrasives that could damage the finish.

**For stainless steel:** Aluminum polish may be used to polish small scratches and scuffs on the finish. Mild soap may be used also to clean the Sidebar.

**For gloss black finishes:** Mild soap may be used to clean the Sidebar.

### *Passenger Side Installation Pictured*

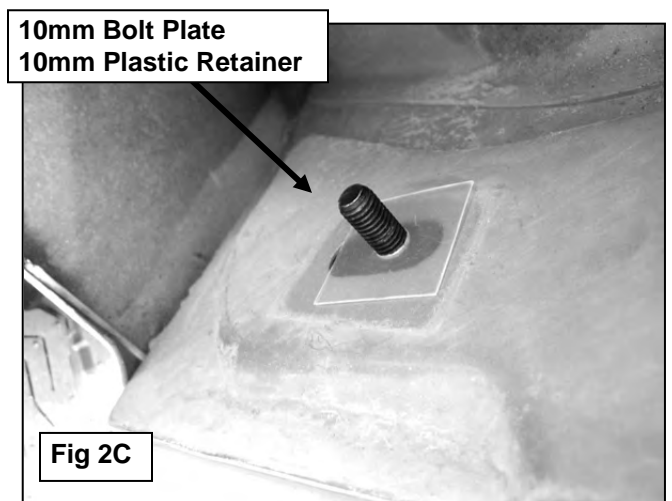
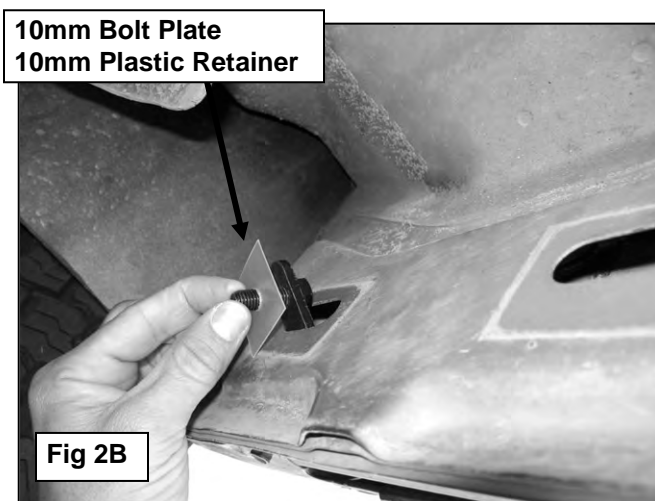
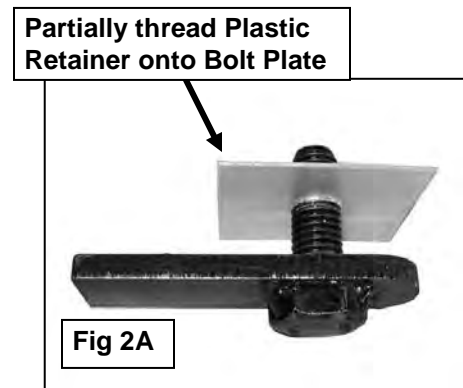
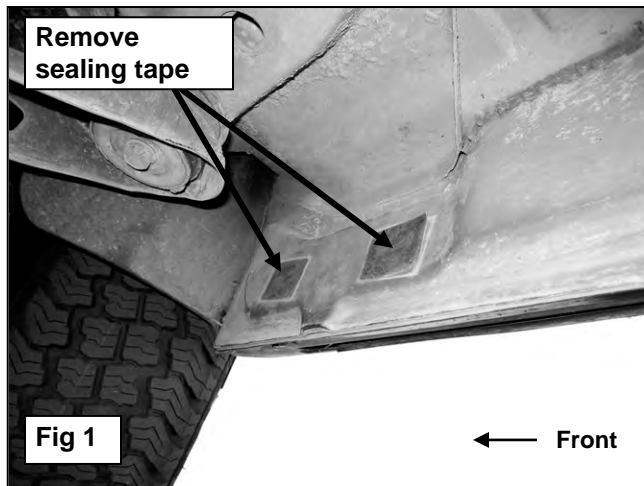

### Passenger Side Installation Pictured

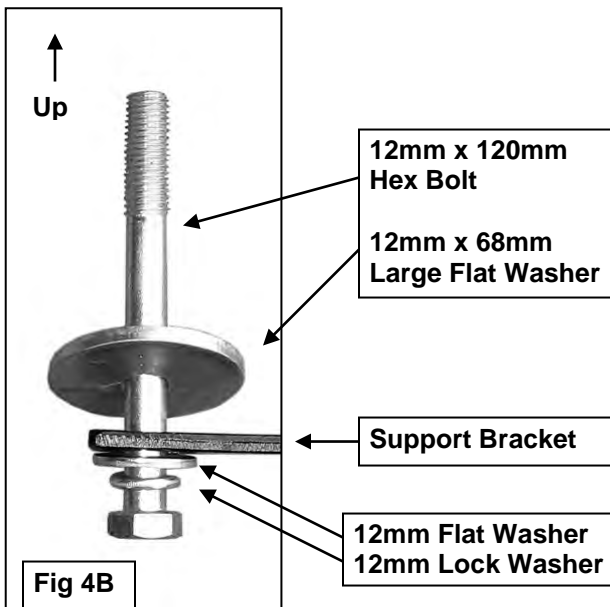
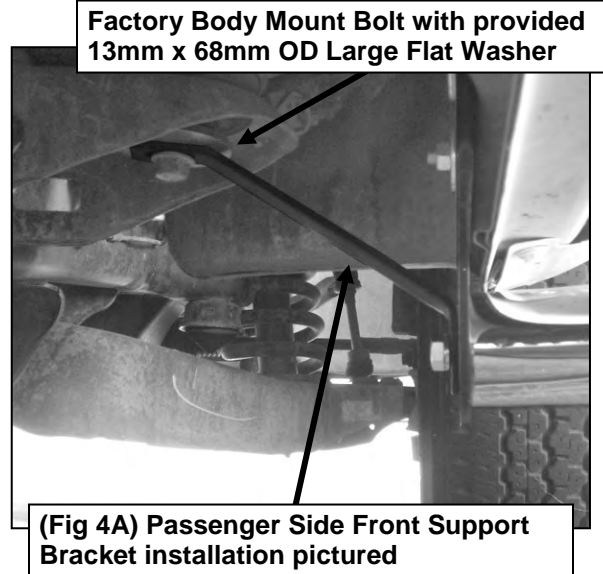
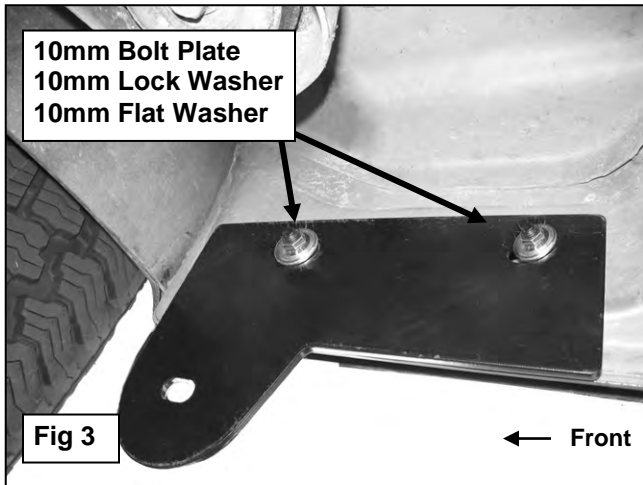

**IMPORTANT!** Depending on model year, there may not be a factory washer and/or the factory body mount bolt may be too short for proper Support Bracket installation. If necessary, replace the factory body mount bolt and washer, (if washer is not removable), with the provided 12mm x 120mm Hex Bolts, 13mm x 68mm Large Flat Washers, 12mm x 32mm Flat Washers and 12mm Lock Washers. If the factory bolt is long enough but there is no factory washer, use the provided 13mm x 68mm OD Large Flat Washers to mount the Support Brackets, (see Figure 4 & 5). It is the installer's responsibility to determine the correct hardware for proper installation.

Factory Body Mount Bolt with  
provided 13mm x 68mm OD  
Large Flat Washer

