



INSTALLATION INSTRUCTIONS

LD-1 REAR BUMPER

2009-16 RAM 1500 PART#R102617 R102620

#PW017838

PARTS LIST:

1	LD1 Rear Bumper Assembly	4	12-1.75mm x 40mm Hex Bolts
1	Push in License Plate Light	4	12mm x 37mm x 3mm Flat Washers
2	Plastic Plugs for license plate mount	4	12mm Lock Washers
4	Sensor Hole Plugs	1	6mm Wrench
1	Step Hole Plug	8	4mm x 10mm Button Head Bolts
2	12mm Double Nut Plates	1	4mm Wrench
		10	Nylon Cable Ties 200mm

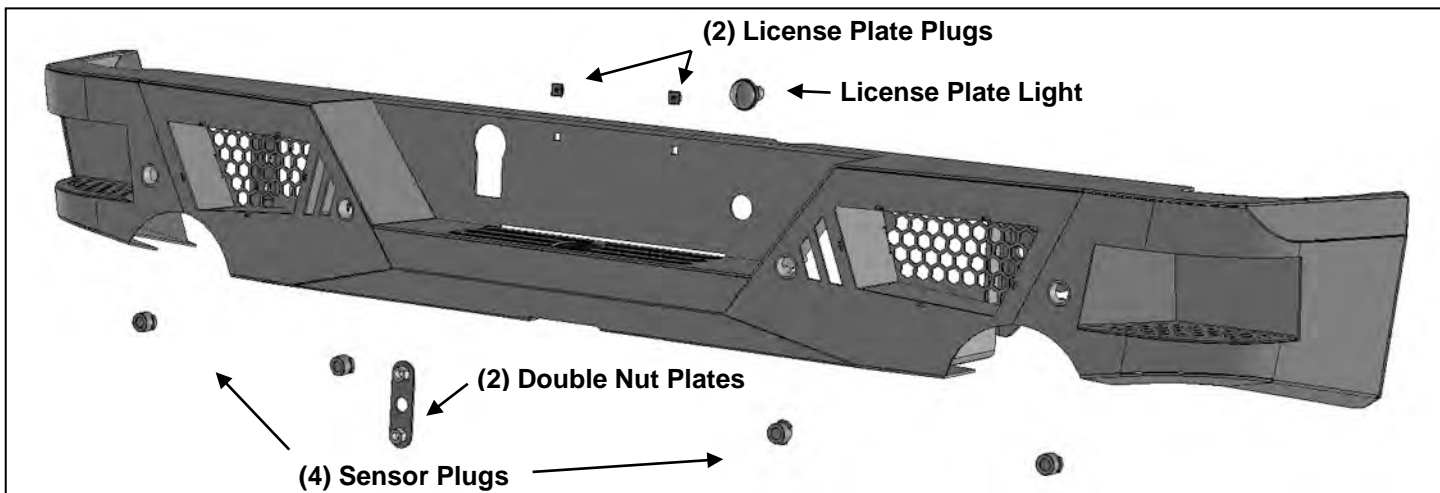

PROCEDURE:

REMOVE CONTENTS FROM BOX. VERIFY ALL PARTS ARE PRESENT. READ INSTRUCTIONS CAREFULLY BEFORE STARTING INSTALLATION. BUMPER IS HEAVY, ASSISTANCE IS HIGHLY RECOMMENDED TO AVOID POSSIBLE INJURY OR DAMAGE TO THE VEHICLE. ON MODELS WITH DUAL EXHAUST, ALLOW EXHAUST TO COMPLETELY COOL BEFORE STARTING INSTALLATION.

1. Start installation by unplugging the license plate lights, towing harness plug and sensors if equipped, **(Figures 1—3)**. Move the wiring harness away from the bumper. Remove the license plate.
2. Place blocks or jack stands under the bumper to support it during bumper bolt removal. Once the bumper has been safely supported, remove the (2) hex bolts behind the license plate, **(Figure 4)**. Next, remove the (4) factory bumper bolts, (2 per side), and slide the rear bumper off of the end of the frame, **(Figures 5 & 6)**. **WARNING!** Assistance is required to hold the bumper in place during hardware removal and to prevent the bumper from falling. Move the bumper to a clean stable work surface.
3. **NOTE:** LD1 Bumper has mounting locations for auxiliary back up or flood light installation. If installing lights at this time, check for clearance around light. Remove back screens from light housings for additional clearance around lights as required, **(Figure 7)**. **IMPORTANT:** On models with Dual Exhaust, screens must be removed before installing the Bumper if lights are to be installed.
4. Remove the outer towing harness plug from the bumper, **(Figure 8)**. Snap the plug into the opening in the LD1 Bumper, **(Figure 9)**. If necessary, use a flat blade screwdriver to carefully pry the lock tab on the clip out to help lock plug in place.
5. Insert the included (2) push-in plugs to attach the license plate to the Bumper, **(Figure 10)**. Insert the included License Plate Light into the mounting hole in the bumper, **(Figure 10)**.
6. **Models with bumper mounted sensors:**
 - a. Remove the sensors from the plastic sleeves in the factory bumper, **(Figure 11)**.
 - b. Remove the rubber plugs from the sockets in the LD1 bumper assembly, **(Figure 12)**.
 - c. Push each sensor in from the back of the bumper. Secure each sensor to the socket with (2) 4mm x 10mm Button Head Screws, **(Figure 12)**. **IMPORTANT:** Sensors fit snug in sockets. The 4mm Screws are used to apply slight pressure to lock the sensors in place. Tighten both screws evenly until they touch the sensor body only. Do not overtighten screws or damage to sensors will result.

7. With assistance, position the LD1 Bumper up to the bumper brackets on the ends of the frame, **(Figure 6)**. Temporarily support the weight of the Bumper Assembly. **WARNING:** To avoid possible injury or damage to the vehicle, do not proceed until the Bumper is fully and safely supported.
8. Line up the (2) mounting holes in the back of the driver side of the bumper with the brackets on the end of the frame. Slide (1) 12mm Double Nut Plate into place behind the mounting plate, **(Figure 13)**. Attach the Bumper to the frame and Nut Plate with (2) 12mm Hex Bolts, (2) 12mm Lock Washers and (2) 12mm Flat Washers, **(Figures 13 & 14)**. Leave hardware loose at this time. Repeat to attach the passenger/right side of the Bumper to the frame bracket.
9. Slowly open the tail gate and check for clearance. Level and adjust the LD1 Bumper and tighten all hardware.
10. Connect the license plate light harness to the License Plate Light. Reattach the wiring harness to the back of the trailer plug and back up sensors (if equipped). Use the included Wire Ties to secure the wiring harness to the bumper and frame. Seal off any open wire connections.
11. Do periodic inspections to the installation to make sure that all hardware is secure and tight.

To protect your investment, wax this product after installing. Regular waxing is recommended to add a protective layer over the finish. Do not use any type of polish or wax that may contain abrasives that could damage the finish. Mild soap may be used to clean the LD1 Bumper assembly.

Passenger side installation pictured

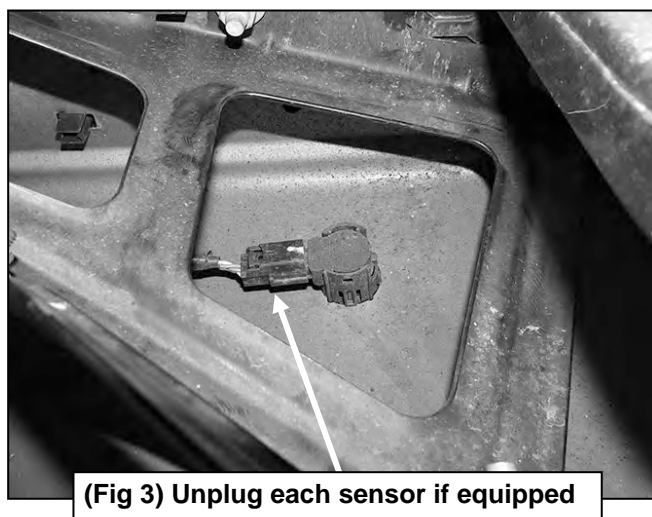
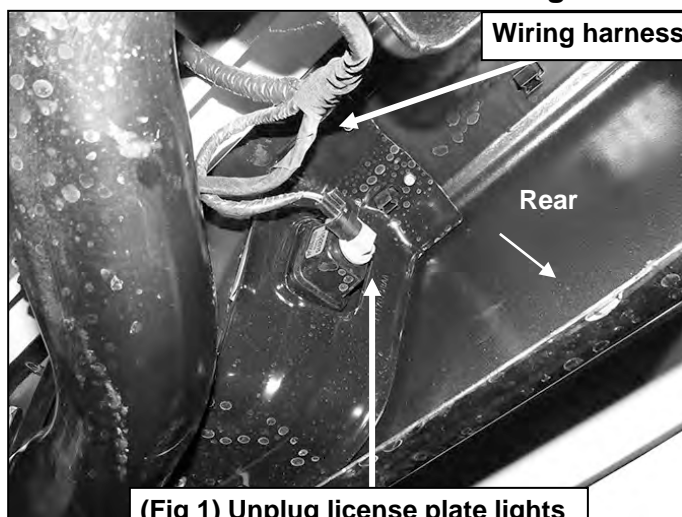

WARNING! Do not remove bumper bolts unless the bumper is properly supported on blocks or stands or the bumper may fall.

Models with dual exhaust, allow exhaust to completely cool before starting installation

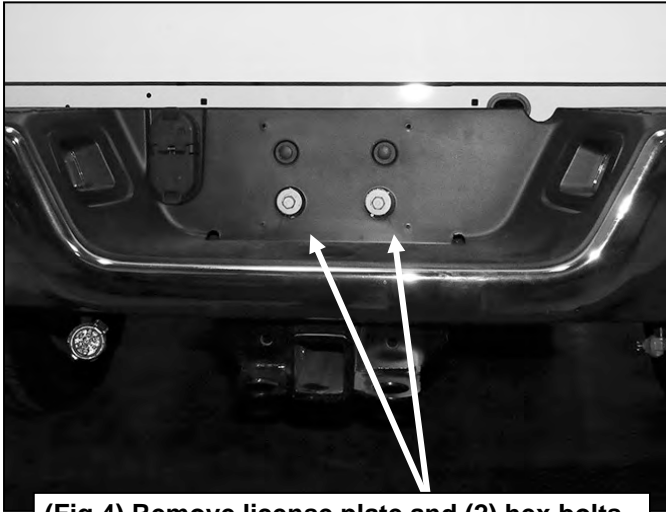

(Fig 4) Remove license plate and (2) hex bolts

WARNING! Do not crawl under bumper unless the bumper is properly supported on blocks or stands or the bumper may fall.

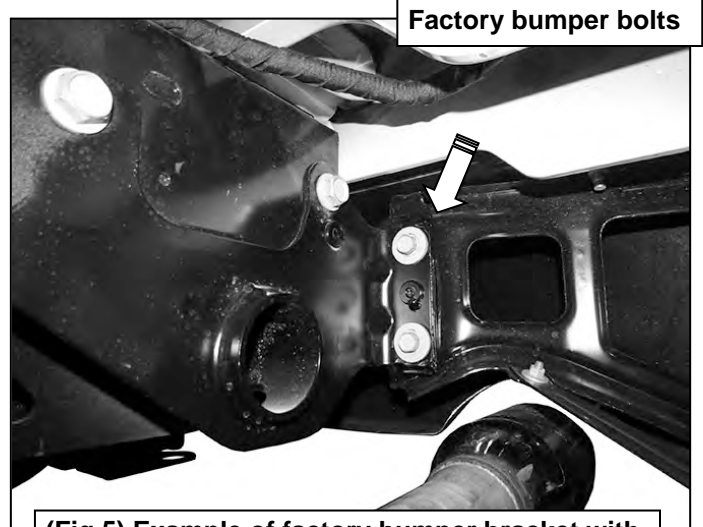

(Fig 5) Example of factory bumper bracket with (2) hex bolts pictured from behind bumper

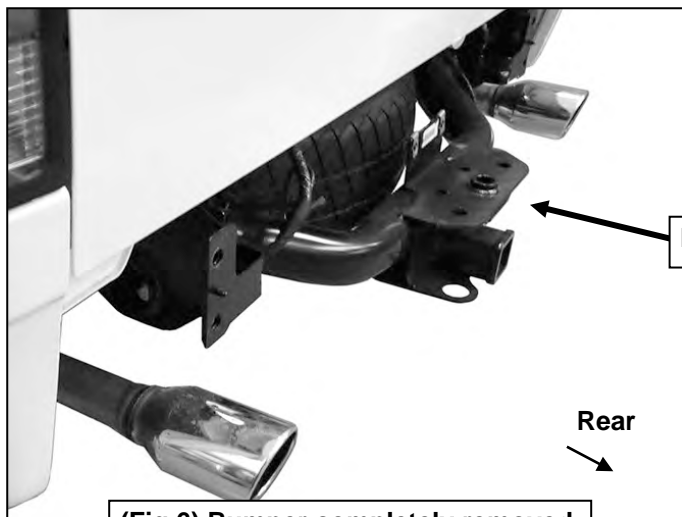

(Fig 6) Bumper completely removed

IMPORTANT: On models with dual exhaust, if bumper installation will include accessory lights, check for clearance around lights before installing bumper. Screens cannot be removed once bumper is installed.

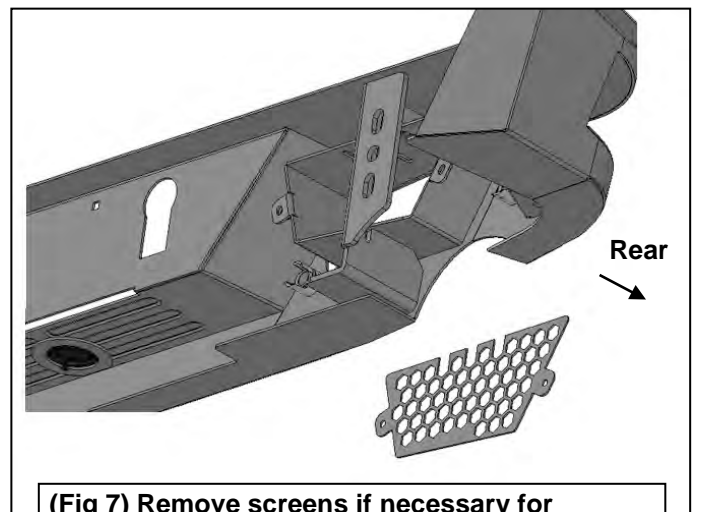

(Fig 7) Remove screens if necessary for additional clearance around or access to lights

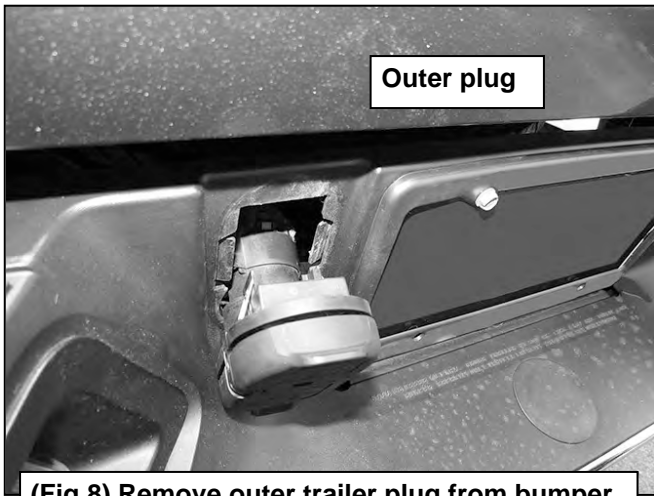

- (2) 12mm Hex Bolts
- (4) 12mm Flat Washers
- (2) 12mm Nylon Lock Nuts

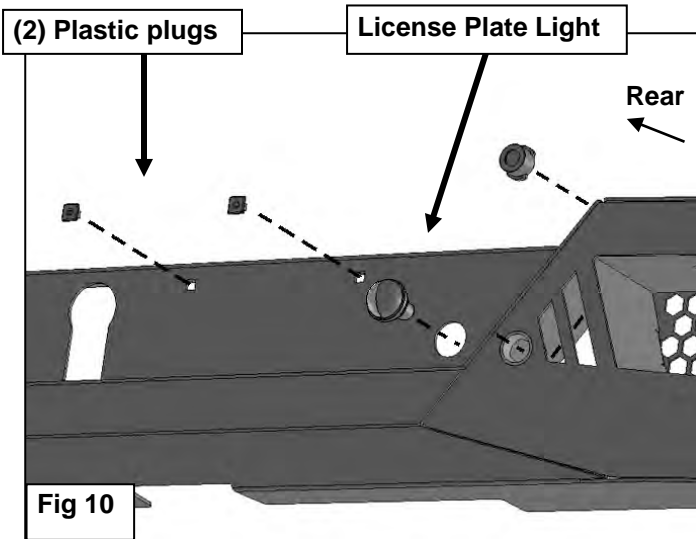
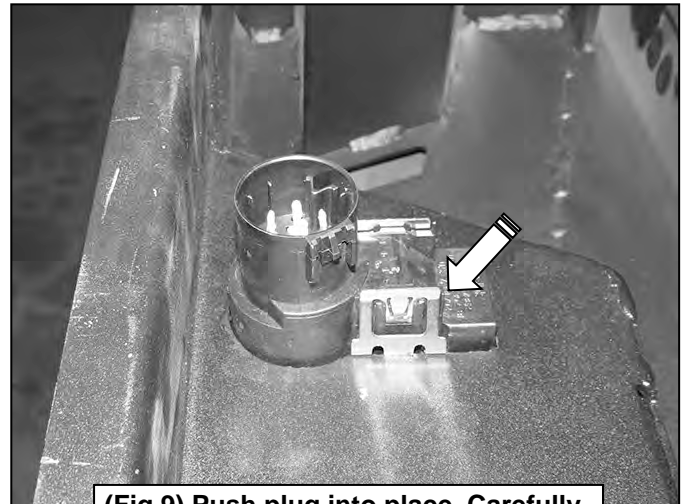

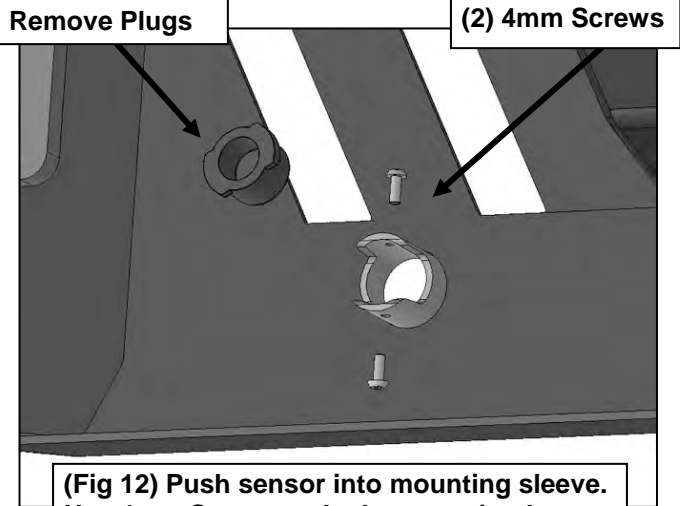

IMPORTANT: Sensors fit snug in sockets. The 4mm Screws are only used to apply slight pressure to lock the sensors in place. Tighten both screws evenly until they touch the sensor body only. Do not overtighten screws or damage to sensors will result.

- (2) 12mm Hex Bolts
- (2) 12mm Lock Washers
- (2) 12mm Flat Washers

WARNING! Do not crawl under bumper unless the bumper is properly supported on blocks or stands or the bumper may fall.

