

# 182705

09-15 DODGE RAM 1500 ROOF LIGHT BAR  
BRACKET KIT (54" RIGID RADIUS LIGHT)

# OFF CAMBER FABRICATIONS

by: **MBRP** INC.

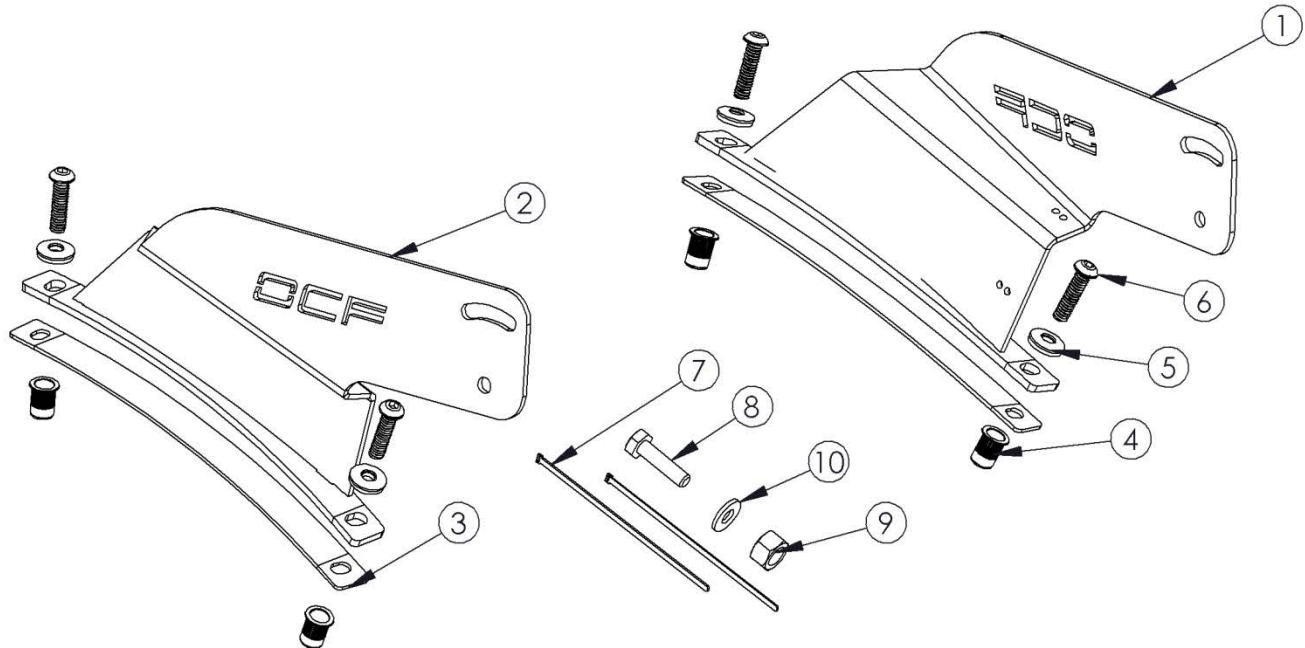

1. DRIVER-SIDE BRACKET
2. PASSENGER-SIDE BRACKET
3. SEAL (2 PCS)
4. 1/4" RIVET NUT (4 PCS)
5. 1/4" RUBBER-BACKED WASHER (4 PCS)
6. 1/4" BUTTON-HEAD HEX BOLT (4 PCS)
7. CABLE TIE (2PCS)
8. 1/4" HEX BOLT
9. 3/8" HEX NUT
10. 1/4" WASHER
11. INSTALLATION TEMPLATE (NOT SHOWN)

## PLEASE READ BEFORE STARTING INSTALLATION

While MBRP Inc. has made every effort to ensure that all components of this kit are of superior quality and properly packaged, it is the installer's responsibility to ensure the following before starting:

- that ALL components shown above are present.
- that ALL mating components fit together.
- that there are no damaged components.
- that the kit you have purchased is appropriate for your year and model of vehicle.
- that the kit will not interfere with any modifications previously installed or planned.
- that you have read and understand these instructions.

If you have any questions or are uncertain about any aspect of the installation of this kit on your vehicle please contact your dealer before commencing installation.

**Installation of OCF Roof Light Kit**



**Figure 1**



**Figure 2**



**Figure 3**



**Figure 4**



**Figure 5**



**Figure 6**

1. Pull back the driver side windshield molding.  
**Refer to Figure 1.**
2. Cut out the **Driver-Side Installation Template** and position it on top of the gutter molding adjacent to the windshield. Align the “Windshield Edge” with the top of the windshield.  
**Refer to Figure 2.**
3. Mark the “gutter molding cut edge” with a marker.  
**Refer to Figure 3.**
4. Pull back the gutter molding starting at the windshield just enough to cut on the mark. Cut then push the gutter molding back down.  
**Refer to Figure 4.**
5. Tape the **Driver-Side Installation Template** back in place (aligned to windshield and centered in the gutter). Use a center punch and hammer to punch the front and rear drilling locations labeled on the template.  
**Refer to Figure 5.**
6. Remove the **Driver-Side Installation Template** and drill pilot holes (1/8”) on the punch marks. Slowly work up to a 3/8” hole. Use cutting lubricant if available.  
**Refer to Figure 6.**



**Figure 7**



**Figure 8**



**Figure 9**



**Figure 10**



**Figure 11**

7. File away any burrs or sharp edges to ensure the top of the **Rivet Nut** will sit flat and parallel with the gutter surface. Fill hole circumference with clear silicon. **Refer to Figure 7.**
8. Insert  $\frac{1}{4}$ " **Hex Bolt** through  $\frac{1}{4}$ " **Washer** then  $\frac{3}{8}$ " **Hex Nut** and lastly screw on  $\frac{1}{4}$ " **Rivet Nut**. **Refer to Figure 8.**
9. Apply a small amount of silicon around  $\frac{1}{4}$ " **Rivet Nut** and insert in hole. Set the  $\frac{1}{4}$ " **Rivet Nut** by tightening the  $\frac{1}{4}$ " **Hex Bolt** while holding the  $\frac{3}{8}$ " **Hex Nut** still. Do NOT let the  $\frac{1}{4}$ " **Rivet Nut** turn. Repeat this step to set the second  $\frac{1}{4}$ " **Rivet Nut**. **Refer to Figure 9.**
10. Apply clear silicon to the bottom side of: **Seal, Driver Side Bracket rail** and in the **Rivet Nut**. Position the **Seal** over the **Rivet Nuts**.

*REPEAT STEPS 1-10 ON PASSENGE- SIDE.*

11. Using the  $\frac{1}{4}$ " **Button Head Hex Bolts** and **Rubber Backed Washers**, fasten the **Driver Side Bracket** in place. Make sure the **Rubber Backed Washer** is compressed flat to make a proper seal, but so much to squeeze the rubber out. **Refer to Figure 10**
12. Fasten the **Passenger-Side Bracket** on the light bar. Ensure wiring is on driver side. **Refer to Figure 11**



**Figure 12**



**Figure 13**

13. Install the light bar on the **Driver-Side Bracket** then rest the **Passenger Side Bracket** over the **Seal**. Fasten the **Passenger Side Bracket** in place (as per Step 9).  
**Refer to Figure 12**

14. Run wiring along **Driver-Side Bracket** and secure in place with **Cable Ties**.  
**Refer to Figure 13**

15. Run power wire down A-pillar below molding and into engine bay (*wire as per light bar instructions*).

**Congratulations! You're finished!**

We are sure that you will enjoy this *Off Camber Fabrications* product by *MBRP Inc.*