

# Raptor Series



**Your satisfaction is important to us, please let us help!**

If you have any questions or concerns during the installation, our support representatives are available to assist you.

Please call: 1-877-769-3765 or Live Chat at [www.raptorseries.com](http://www.raptorseries.com)

If you have damaged or missing parts please contact the company you purchased the product from and notify them of the issue right away.



**CAUTION: Do not install damaged parts!!!**

# Raptor Series

## Easy Return / Easy Exchange

---

### **Want to return an item or exchange? Not satisfied with purchase?**

No problem. We strongly believe in service after the sale and we stand behind our products and our service to you, our valued customer. There is no problem we can't solve for you!

Items that have been installed and/or damaged after receipt, are no longer in new and ready-to-sell condition and cannot be refunded, replaced or exchanged unless it has a manufacturer defect or was damaged in shipping. In addition, we cannot accept return on items that are not in the original packaging. Items returned in poor condition or having parts missing will not be credited.

**Please note: Your request for return or replacement must be initiated within 30 days of delivery of your merchandise.**

### **Did your order arrive damaged?**

Please do not install damaged products. Contact the company you purchased your product from as soon as possible and notify them of the damages. They will make arrangements with you to assist with the problem.

### **Did you order the wrong part or receive the wrong item?**

Don't worry. From time to time human error can result in problems with ordering or shipping. Contact the company you purchased your product from as soon as you notice the error. Every company has their own policy on returning parts that have been ordered incorrectly or shipped incorrectly.

In the event that you need to ship your part back to return/exchange, please ship to the warehouse below:

**CYC Returns Warehouse  
2415 Cathy Lane  
Jasper, IN 47546**

The logo for the Raptor Series, featuring the word "Raptor" in a green, cursive font and "Series" in a black, bold, sans-serif font below it.

## Raptor Series Warranty

### LIMITED TEN (10) YEAR WARRANTY

#### For Powder Coated Steel Products

CYC Engineering, Inc. guarantees the original purchaser of our products a limited ten (10) year warranty from the date of original purchase against manufacturer defects in materials, workmanship and finish under normal use. The step pads are covered under warranty for 1 year. This warranty does not include damage resulting from road hazards such as gravel or other debris, product misuse, improper installation, impairments from accidents, product modifications, product neglect or scratches during the life of the product. This limited ten year warranty applies only to new products and is limited to the repair or replacement of company's products. Warranty does not include costs of removal, installation, labor, inconvenience or consequential damages. Original purchaser must return defective merchandise along with the purchase receipt, to the original place of purchase.

### LIMITED LIFETIME WARRANTY

#### For Stainless Steel Products

CYC Engineering, Inc. guarantees the original purchaser of our products a limited lifetime warranty from the date of original purchase against manufacturer defects in materials, workmanship and finish under normal use. The step pads are covered under warranty for 1 year. This warranty does not include damage resulting from road hazards such as gravel or other debris, product misuse, improper installation, impairments from accidents, product modifications, product neglect or scratches during the life of the product. This limited lifetime warranty applies only to new products and is limited to the repair or replacement of company's products. Warranty does not include costs of removal, installation, labor, inconvenience or consequential damages. Original purchaser must return defective merchandise along with the purchase receipt, to the original place of purchase.

0102-0531

# 3" ROUND TUBE



### Components:

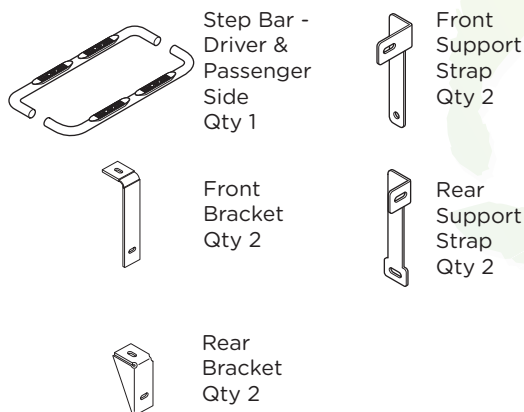

### Hardware:

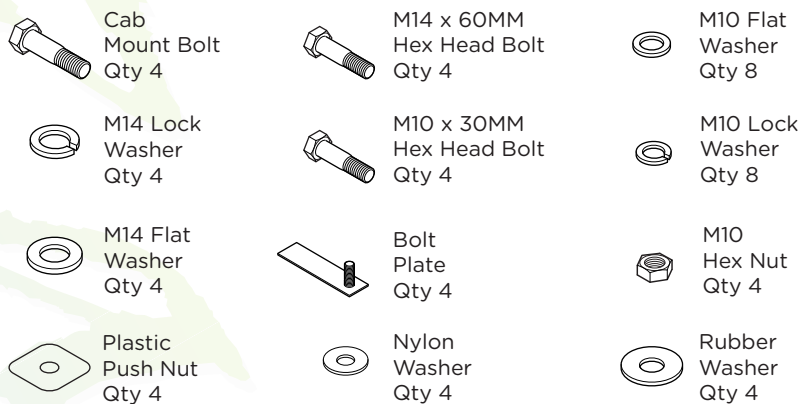

### Tools Required:

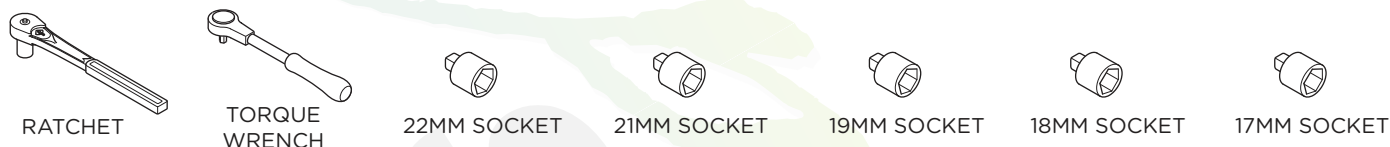

### Torque Specifications:

For Cab Mount Installations

Cab Mount bolts are torqued to 70 Ft Lbs. All other M8 through M12 sized bolts/nuts are set to 15-20 ft lbs.

**Note: When installing the brackets and bars, all hardware must be left loose until all the items are attached.**

**1.** Remove all contents from the package and check stainless steel tubes for any damage. Also, verify that all components and hardware listed above are included before you begin installation.

**2.** Read installation manual and installation drawing completely. Understand all brackets and bolts before installation.

**3.** Begin installation on the driver's side. Remove the existing body mount bolts from underside of cab on driver side, keep the existing rubber bushing and other components in order.

**Note:** Make sure existing washer and rubber bushing is in place.

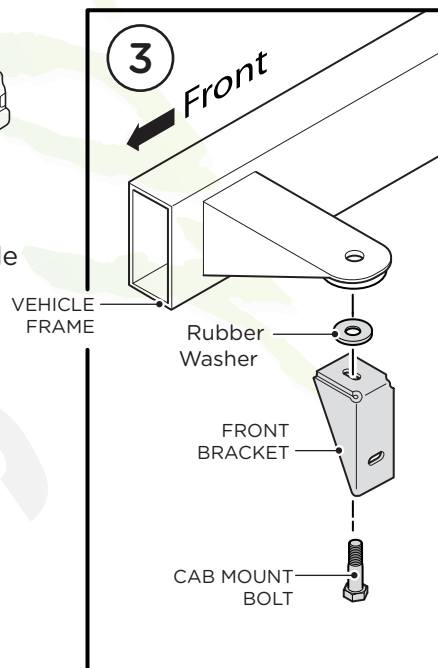
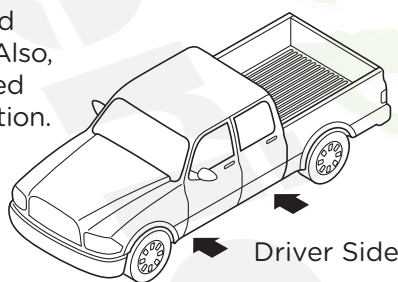

**4.** Install the Rear Bracket using the Rear Cab Mount Bolt as shown in diagram. Place one (1) Rubber Washer between the bracket and the existing rubber bushing.

**5.** Place the Plastic Push Nut onto the threaded bolt of the Bolt Plate (5a and 5b). Locate the oblong hole in the side of the body panel near the front and insert one (1) Bolt Plate (5c).

**6.** Fasten the Step Bar to the Front and Rear Brackets using one (1) M14 x 60MM Bolt, one (1) M14 Lock Washer and one (1) M14 Flat Washer per bracket.

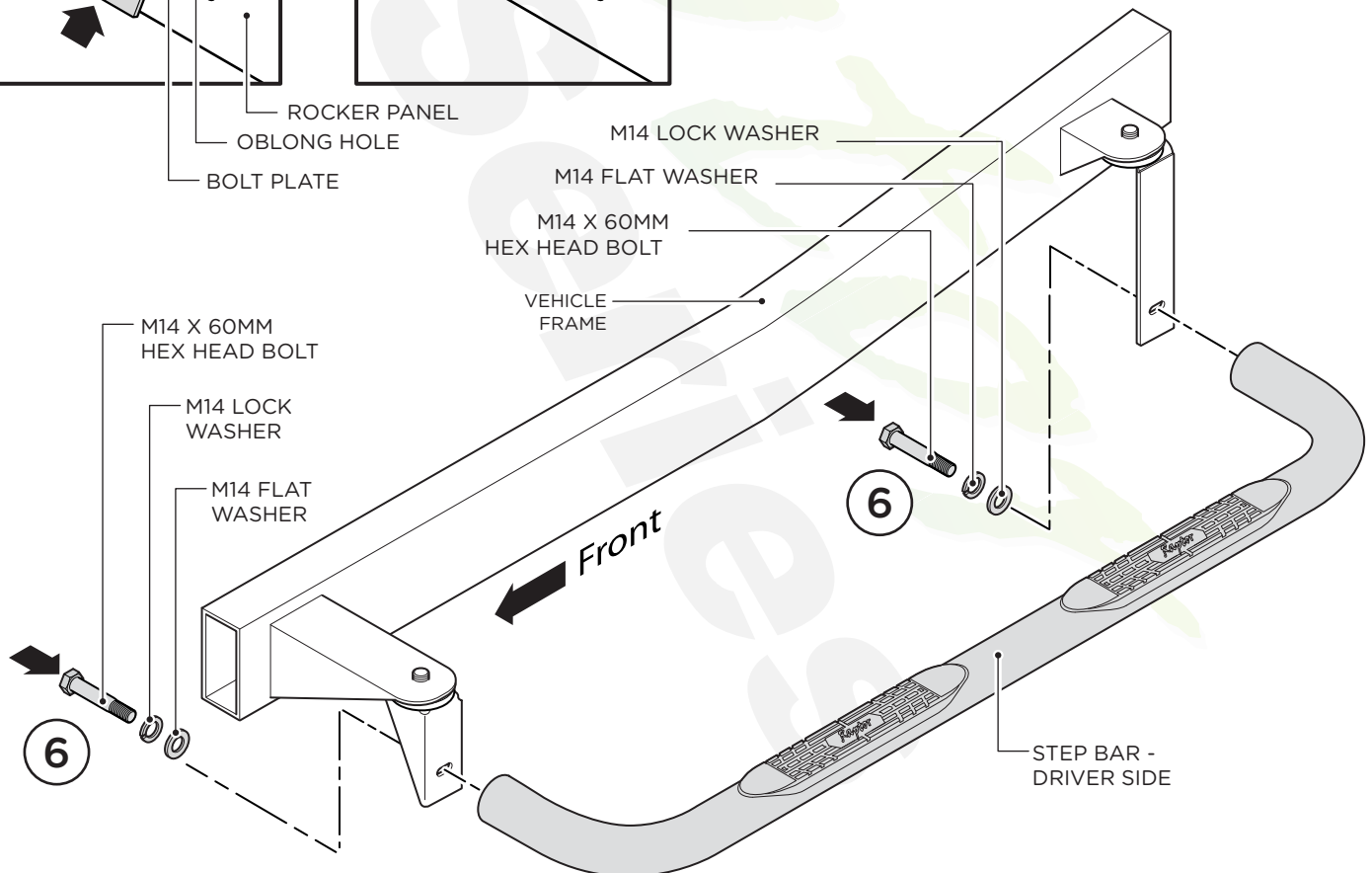
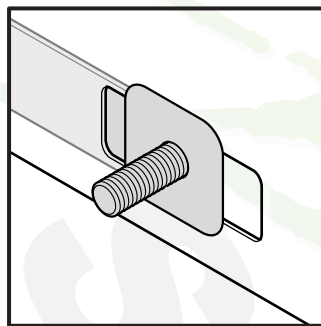
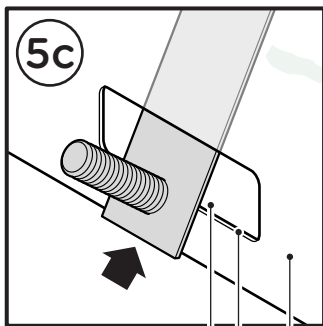
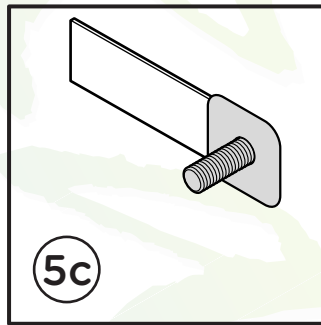
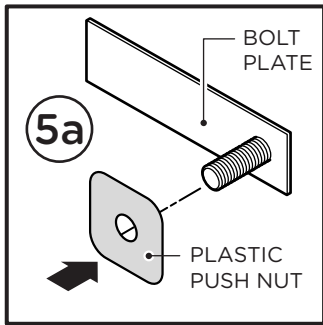
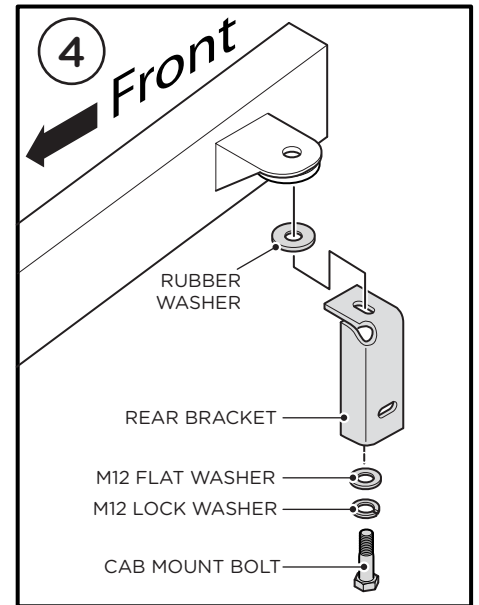

**7.** Fasten the Front and Rear Support Straps to the Step Bar using one (1) Nylon Washer, one (1) M10 Flat Washer, one (1) M10 Lock Washer and one (1) M10 Hex Head Bolt (8a) per strap.

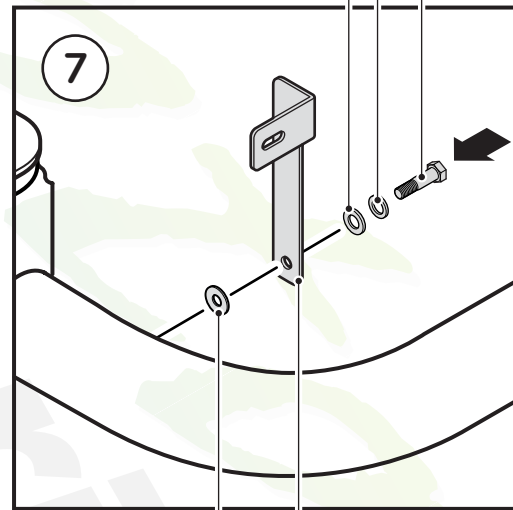
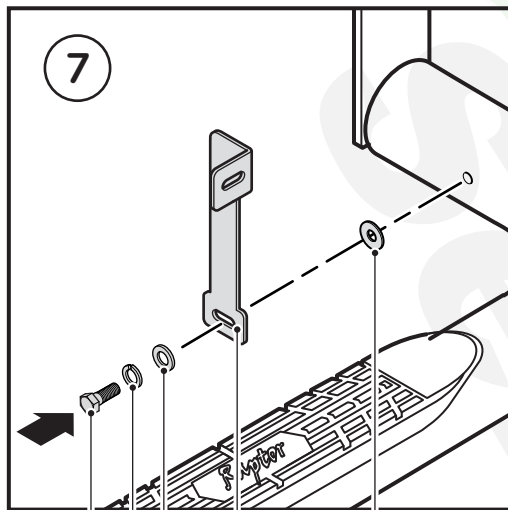
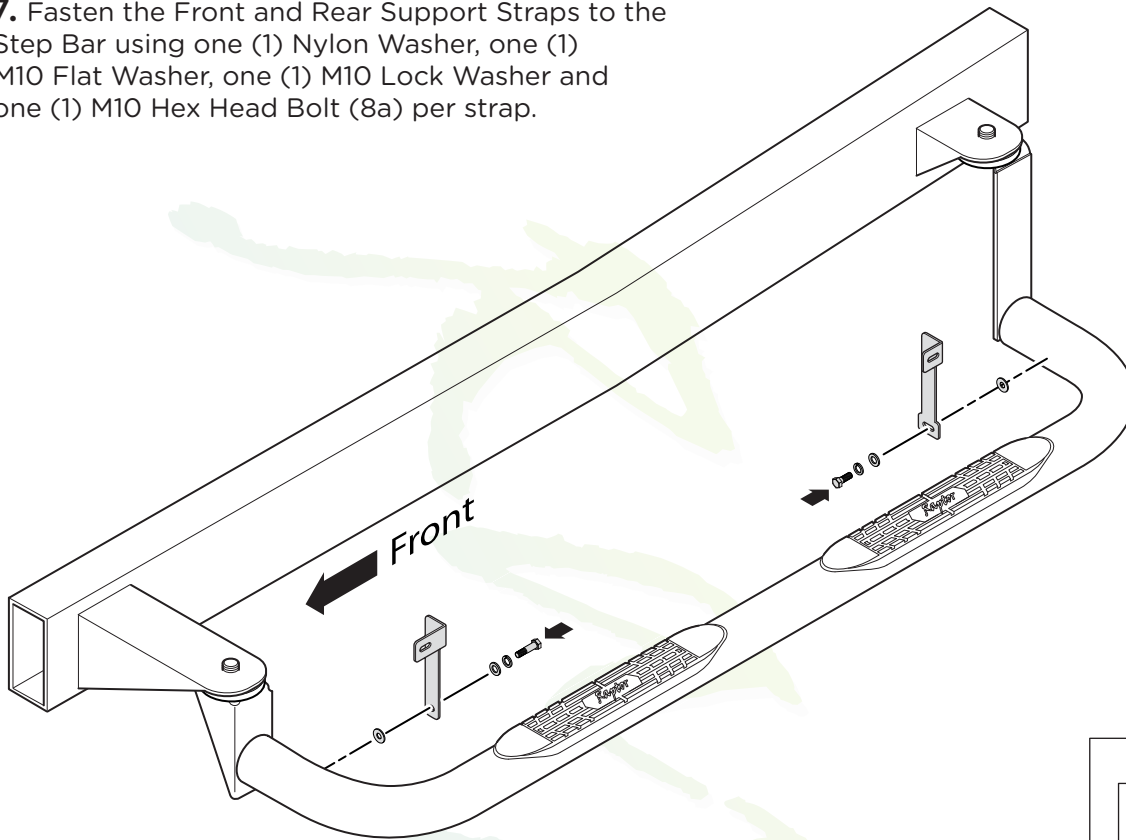

- NYLON WASHER
- FRONT SUPPORT STRAP
- M10 FLAT WASHER
- M10 LOCK WASHER
- M10 x 30MM HEX HEAD BOLT
- M10 FLAT WASHER
- M10 LOCK WASHER
- M10 x 30MM HEX HEAD BOLT
- FRONT SUPPORT STRAP
- NYLON WASHER

**8.** Fasten the Front and Rear Support Straps to the Bolt Plates installed in step 5 using one (1) M10 Hex Head Nut, one (1) M10 Flat Washer and (1) M10 Lock Washer per strap.

Repeat these steps for passenger side installation. When all hardware is in place, everything must be tightened. See Page 1 for Torque Specifications.

