

AMP RESEARCH BedStep2™

Chevy Silverado / GMC Sierra
1500 1996-2013 (all Beds)
2500/3500 1996-2014 (all Beds)

PART NUMBER:
75400-01A

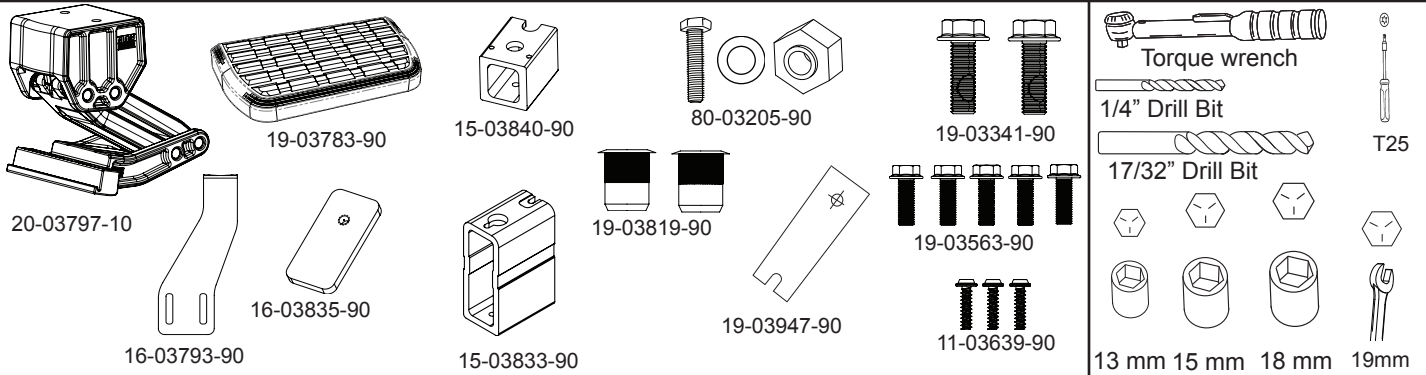

Brackets must be configured as shown. Note: Driver Side shown, Mirror for Passenger side.

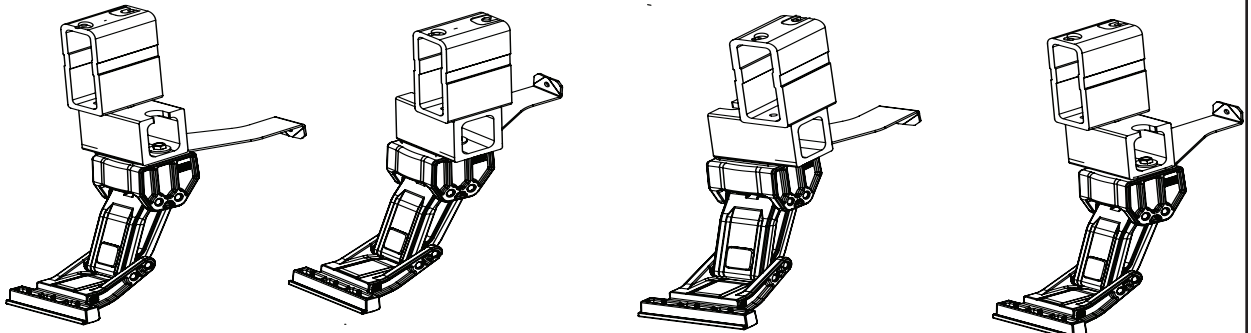

Driver side configuration for:
 HD 2500/3500 with 6.5 & 8' Bed Lengths
 1500 with 8' & 6.5' Bed Lengths

Driver side configuration for:
 1500 with 5.5' Bed Length

Passenger side configuration for:
 HD 2500/3500 with 6.5 & 8' Bed Lengths
 1500 with 8' & 6.5' Bed Lengths

Passenger side configuration for:
 1500 with 5.5' Bed Length

Note: On 1500 Models with 5.5' bed lengths aftermarket fender flares may contact step pad.

1

Using a 15mm Socket assemble Lateral mount onto Linkage assembly. Steel bracket is to be assembled between linkage and lateral mount. Do not tighten bolts yet. **See step 1 for bracket orientation based on chassis and bed length.**

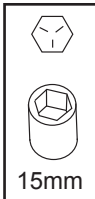
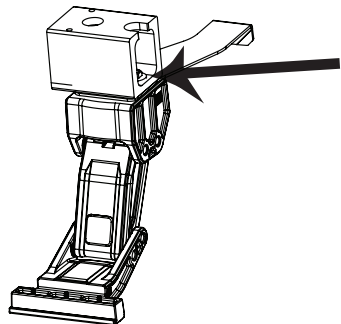

15mm

Using a 13mm Socket assemble Frame mount onto Lateral mount. Torque bolts to 16 ft-lbs.

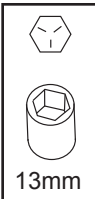
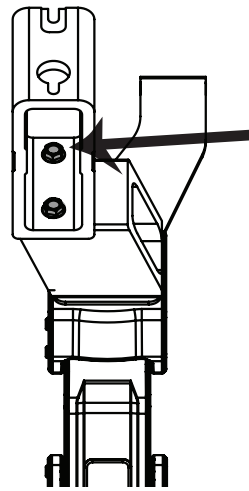

13mm

2 NOTE: DRIVER SIDE SHOWN. MIRROR FOR PASSENGER SIDE.

3

AMP RESEARCH TECH SUPPORT 1-888-983-2204 (Press 2) Monday - Friday, 6:00 AM - 5:00 PM PST

BedStep2™ is invented, designed, engineered and manufactured exclusively by AMP Research and may be covered by one of the following patents: 6,641,158; 6,830,257; 6,938,909; 7,055,839; 7,380,807; 7,398,985; 7,584,975. Made in USA © 2011 AMP Research
 Three-year limited warranty. Professional installation is recommended.

On 2011 and newer HD model trucks remove 8mm bolt from bed channel. Using supplied template mark the hole for the inner bolt on the front bed channel. Pre drill using a 1/4" drill bit then drill to a 17/32". Install rivet nut in drilled hole. With Rivet Nut Tool held in place with 19mm wrench, tighten Hex Bolt until Rivet Nut deforms and secures itself to the sheet metal (20 ft-Lbs. or 4 turns). Remove Hex Bolt and Rivet Nut Tool. Start provided bolt into factory bracket. If plate is not present use provided threaded plate to attach linkage assembly to bed channel. (P/N 16-03835-90) Next start bolt into rivet nut. Do not tighten!

WARNING: Rivet Nuts not properly collapsed will not hold securely to sheet metal.

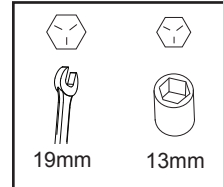
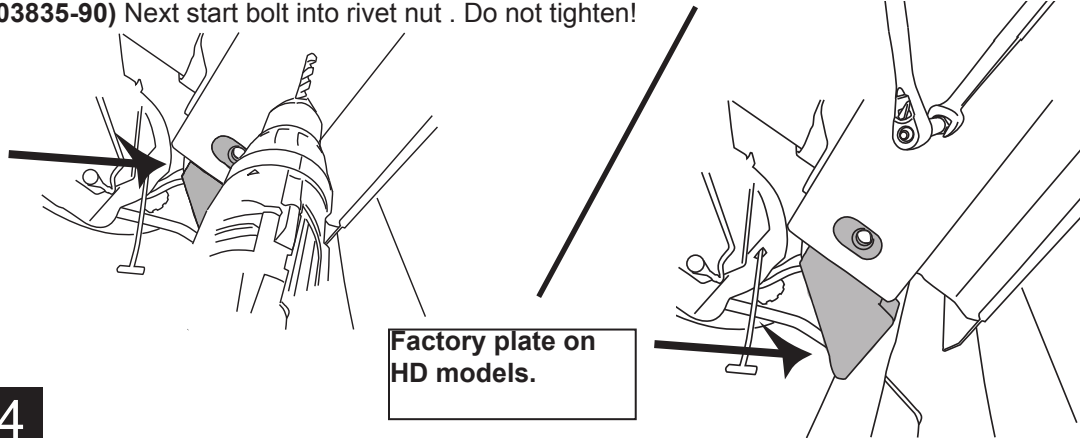

4

Slide linkage assembly into slot and slide into position. Tighten bolt using a 13mm and torque to 16ft-lbs.

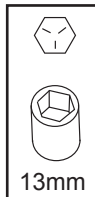
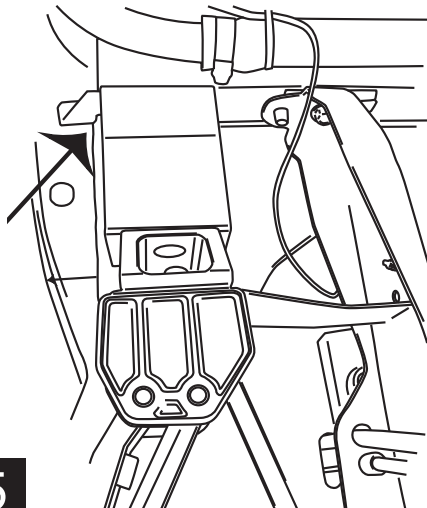

5

Locate the step pad on the center position of the lower linkage assembly and secure using provided PT Screws. Tighten to 5 ft-lbs using T25 torx bit.

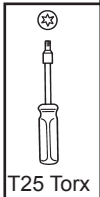
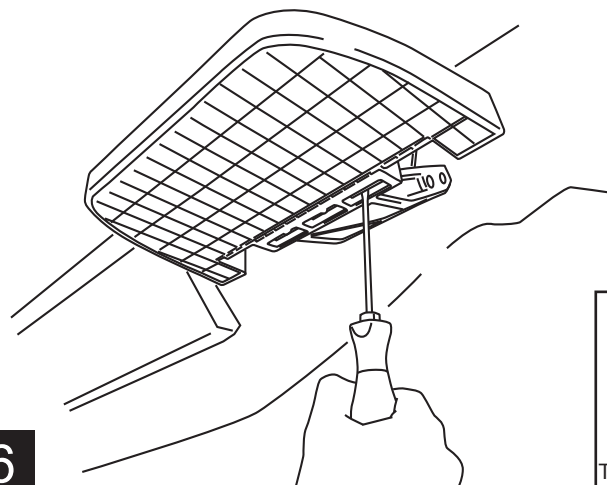

6

Adjust step pad to be in line with fender.

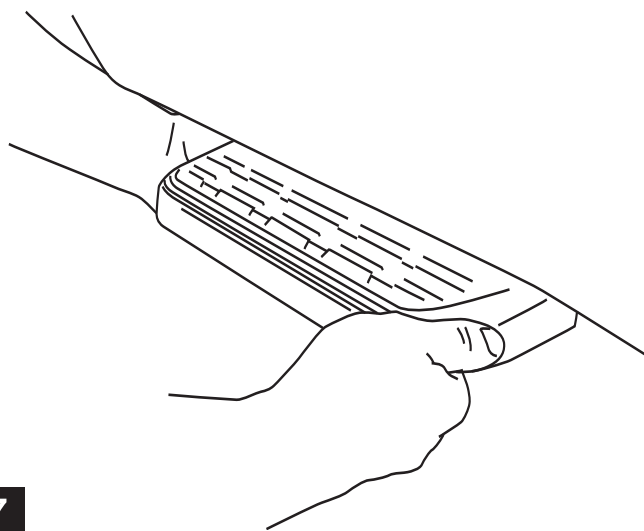

7

Slide steel bracket up to frame and mark hole location to be drilled.

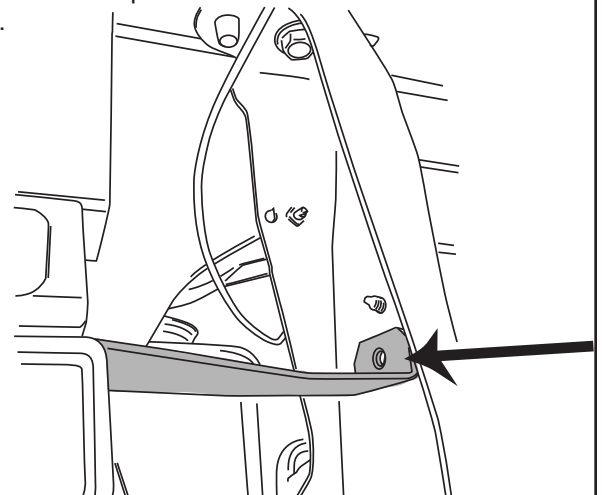

8

Note: Frame section may vary based on wheelbase and chassis.

Remove Linkage assembly and center punch hole.

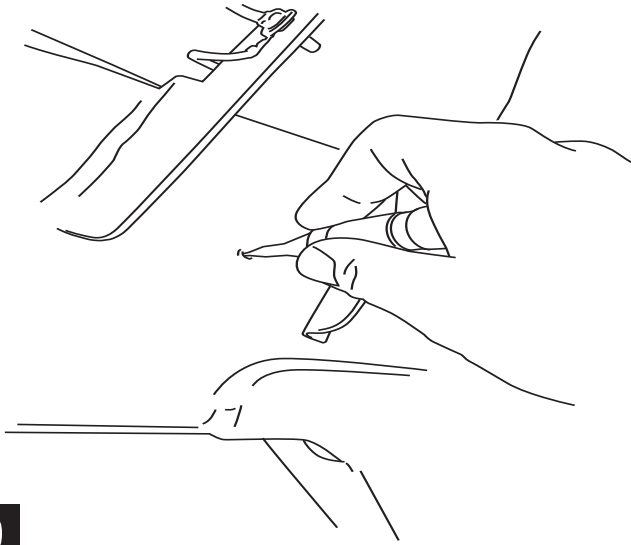

9

Pre drill hole using a 1/4" Drill bit. Next drill hole to 17/32".

WARNING: Fuel tank on back side of frame rail. Do NOT drill through second wall of boxed frame rail.

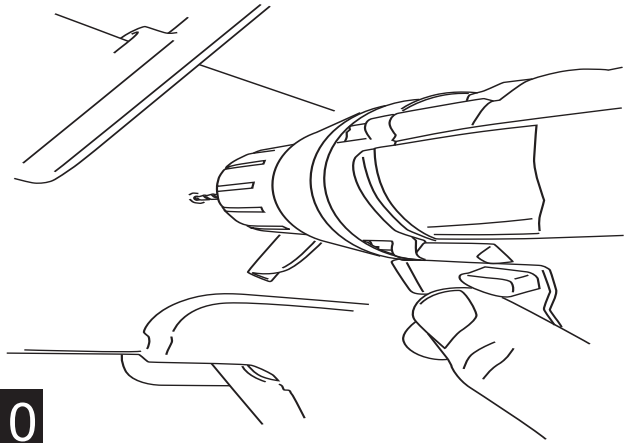

10

With Rivet Nut Tool held in place with 19mm wrench, tighten Hex Bolt until Rivet Nut deforms and secures itself to the sheet metal (20 ft-Lbs. or 4 turns). Remove Hex Bolt and Rivet Nut Tool.

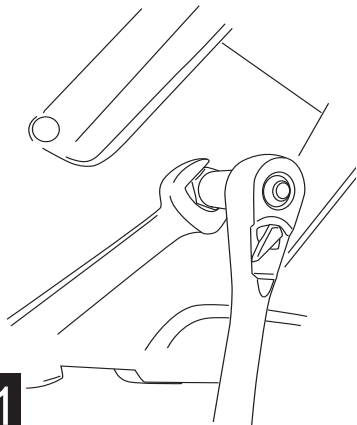

WARNING: Rivet Nuts not properly collapsed will not hold securely to sheet metal.

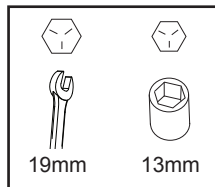

11

Assemble linkage into place and tighten with 13mm socket (Torque to 16 ft-lbs). Next install bolt on bracket and tighten using a 13mm socket (Torque to 16 ft-lbs).

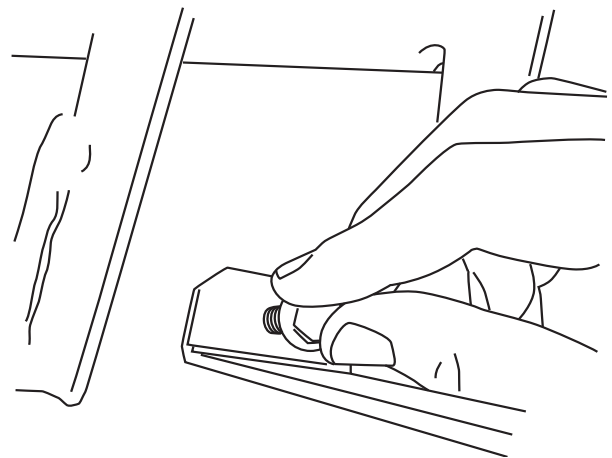

12

Adjust step pad to be in line with fender.

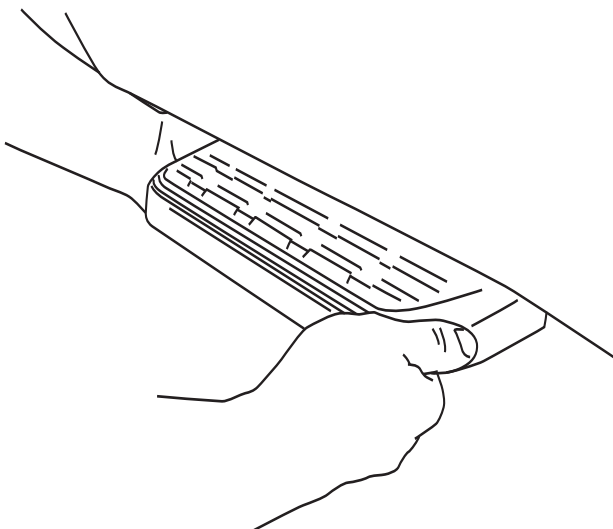

13

Tighten bolts using a 15mm socket or wrench. Torque to 20 ft-lbs.

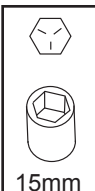
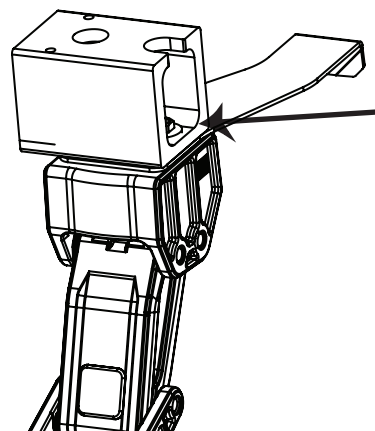

14

To deploy the step, press down using your foot on the outside edge of the step pad.

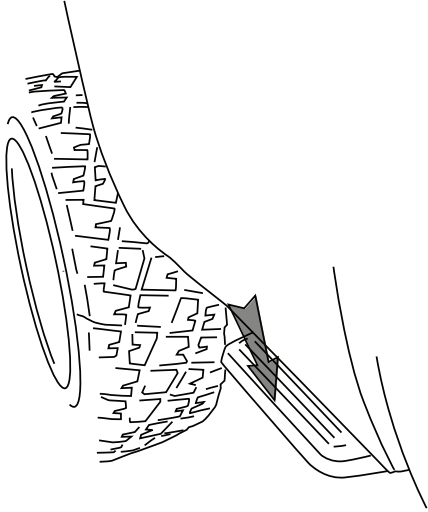

15

To retract, gently kick up on the underside of the step pad.

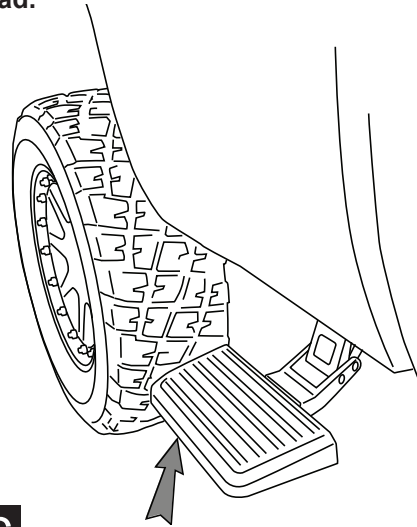

16



Congratulations on your purchase of the genuine AMP Research BedStep2™. Here's what you should know...

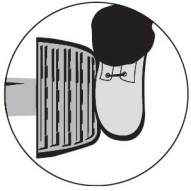

BEDSTEP2™ OPERATION

The AMP Research BedStep2™ is foot operated and deploys and retracts with a nudge of your foot. To deploy, press down using your foot, on the outside edge of the step pad.

Maximum load capacity of the deployed step pad is 300 lbs.

Always use appropriate hand holds when stepping up to or down from your truck's cargo bed.



To retract, gently kick up on the underside of the step pad.

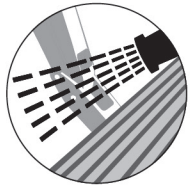

MAINTENANCE TIPS - The stepping surface and linkage should be periodically washed with mild soap and water using a soft brush or sponge to dislodge any mud, dirt or accumulated road grime.

In severe driving conditions, pressure washing the linkage is strongly recommended.

Do not apply silicone spray, waxes or protectants like Armor All® to the stepping surfaces.

CAUTION! BEDSTEP2™ SHOULD ALWAYS BE STOWED IN THE RETRACTED POSITION WHEN DRIVING.

AMP RESEARCH LIMITED WARRANTY

AMP RESEARCH warrants this product to be free from defects in material and workmanship for THREE (3) YEARS FROM DATE OF PURCHASE, provided there has been normal use and proper maintenance. This warranty applies to the original purchaser only. All remedies under this warranty are limited to the repair replacement of the product itself, or the repair or replacement of any component part thereof, found by the factory to be defective within the time period specified. The decision to repair or replace is wholly within the discretion of the manufacturer.

This warranty specifically excludes labor. If you have a warranty claim, first you must call our factory at the number below for instructions. You must retain proof of purchase and submit a copy with any items returned for warranty work. Upon completion of warranty work, if any, we will return the repaired or replaced item or items to you freight prepaid. Damage to our products caused by accidents, fire, vandalism, negligence, misinstallation, misuse, Acts of God, or by defective parts not manufactured by us, is not covered under this warranty.

ANY IMPLIED WARRANTIES OF MERCHANTABILITY AND/OR FITNESS FOR A PARTICULAR PURPOSE CREATED HEREBY ARE LIMITED IN DURATION TO THE SAME DURATION AND SCOPE AS THE EXPRESS WRITTEN WARRANTY. OUR COMPANY SHALL NOT BE LIABLE FOR ANY INCIDENTAL OR CONSEQUENTIAL DAMAGE.

Some states do not allow limitations on how long an implied warranty lasts, or the exclusion or limitation of incidental or consequential damages, so the above limitations or exclusions may not apply to you. This warranty gives you specific legal rights, and you may also have other rights that vary from state to state.

FOR WARRANTY ISSUES WITH THIS PRODUCT PLEASE CALL AMP RESEARCH CUSTOMER SERVICE 1-888-983-2204

WARNING

Be sure to read and precisely follow the provided instructions when installing this product. Failure to do so could place the vehicle occupants in a potentially dangerous situation. After installing or reinstalling, re-check to insure that the product is properly installed.