



**INSTALLATION INSTRUCTIONS FOR BOSS BARS FOR
2007 CHEVYGMC 1500 CREW CAB 5.5' BOX WHEEL TO WHEEL BARS #44289**

Congratulations on your purchase of a high quality PUTCO product.

Should you need any application or technical assistance feel free to call us at: 1-800-247-3974

Monday-Friday 8:00 a.m. - 5:00 p.m. (Central Standard Time)

Contact your PUTCO dealer for other quality accessories.

PUTCO Inc. - 216 West First Street - Story City, Iowa 50248

Please read all instructions before beginning installation and be sure to check to see that all parts and hardware are included.

Parts List	
Description	Qty
Boss Bar (Driver and Passenger)	2
Front Bracket (#1902)	2
Rear Bracket (#2000)	2
Driver Front Support (#1910)	1
Passenger Front Support (#1911)	1
Bolt Plate (#1900)	2
Rear Support (#1901)	2
1/2" x 2" Hex head bolts (#00738)	4
1/2" x 1-1/2" Hex head bolts (#743)	2
1/2" Flat washer (#775)	10
1/2" Lock washer (#783)	10
12mm x 120mm (#789)	2
Rubber Silencer (1964)	8

Tools Needed for Installation
19mm Socket
3/4" Wrench and Socket
Torque Wrench
9/16" Socket

Step 1: Remove the existing body mount bolts at the front and the rear of the cab.

Step 2: Install the front and rear brackets, with the existing body mount bolts. Leave loose at this time.

NOTE: The front bracket is shorter than the rear bracket.

Step 3: Locate the hole on the bottom surface of the frame. It is on the bottom of the frame to the rear of the front body mount.

Step 4: Slide the bolt plate into the frame until the bolt drops through the slotted hole. You will be able to access this hole from the bottom of the frame where there is a slotted hole.

Step 5: Place rubber silencer (1964) between bolt and front support bracket. Fasten the front support bracket to the bolt protruding through the hole in the bottom of the frame.

Step 6: Fasten the rear brace to the existing hole in the side of the body mount using the 1/2" x 1-1/2" hex head bolts. Stick the rubber silencer to the boss bar support bracket so that it is between the boss bar main bracket and support bracket in the in the location indicated in **(see figure 2)**.

NOTE: On certain vehicles this hole may be larger than the bolt and/or used for the emergency brake cable. If this is the case simply drill a 9/16" hole below the factory hole so that the support bracket can be installed

Step 7: Bolt the tube to the support braces and mounting brackets using the 3/4" x 2" hex head bolts.

Step 8: Check to make sure that the Boss Bar is aligned and level. Tighten all mounting hardware to 65ft/lbs.

Note: PUTCO recommends applying a high quality automotive wax to maintain the original appearance on your new Boss Bars.

INSTRUCTION # IN 44289-Nov 2006

LIMITED WARRANTY

Putco guarantees it's Stainless Steel and Aluminum products against defects in workmanship and material for as long as you own your vehicle. Black products have a 90 day warranty on the painted surface. Any defects resulting from faulty material or workmanship will be warranted by Putco and repaired or replaced at our discretion. Putco assumes no extra labor costs. Damages caused by freight carriers, improper installation, misuse, collision, or neglect will not be warranted by Putco.

Figure 1

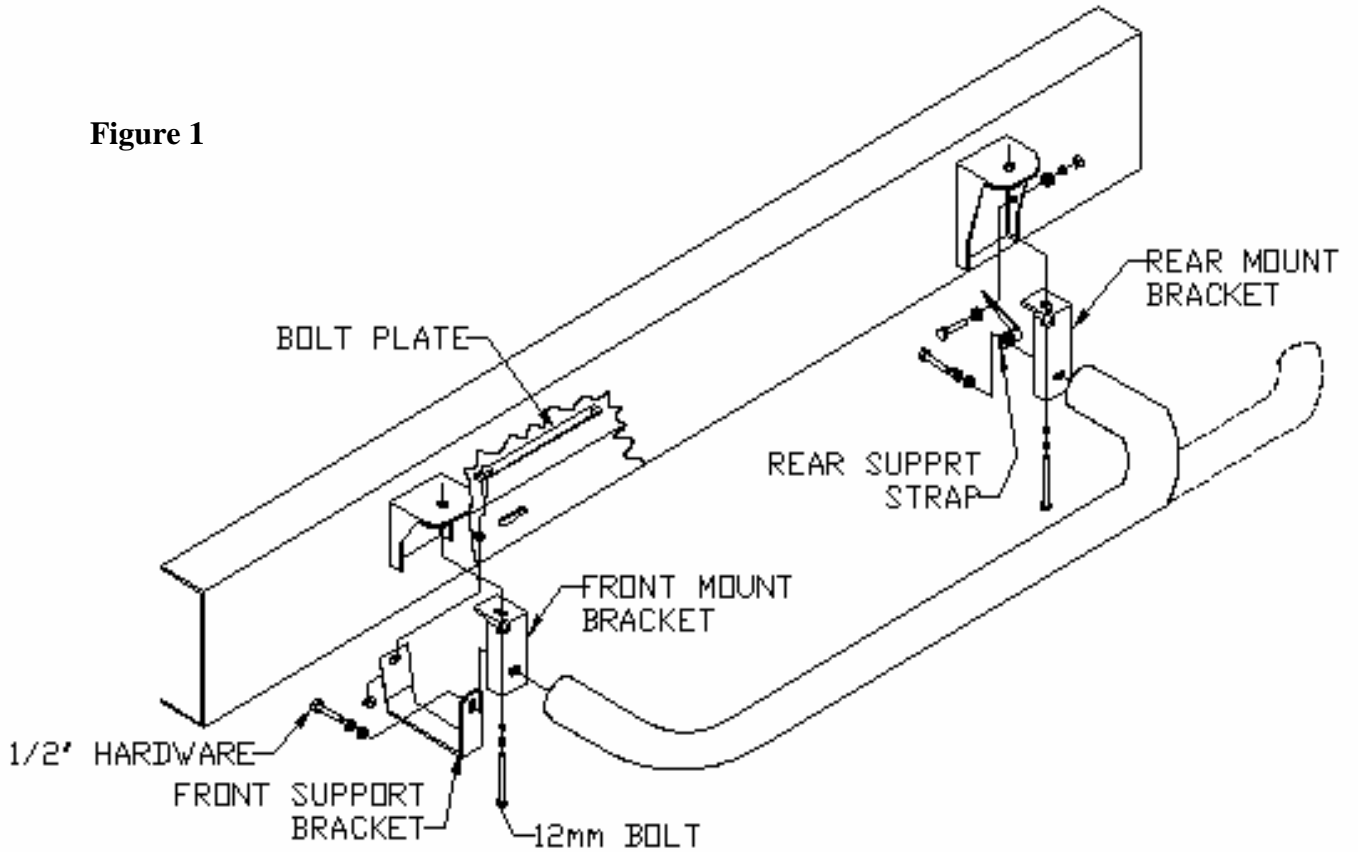

Figure 2

