

S5242

11-13 FORD F150 RAPTOR, 6.2L, EC/CC,
CAT BACK, 3 1/2" SINGLE, TURN DOWN

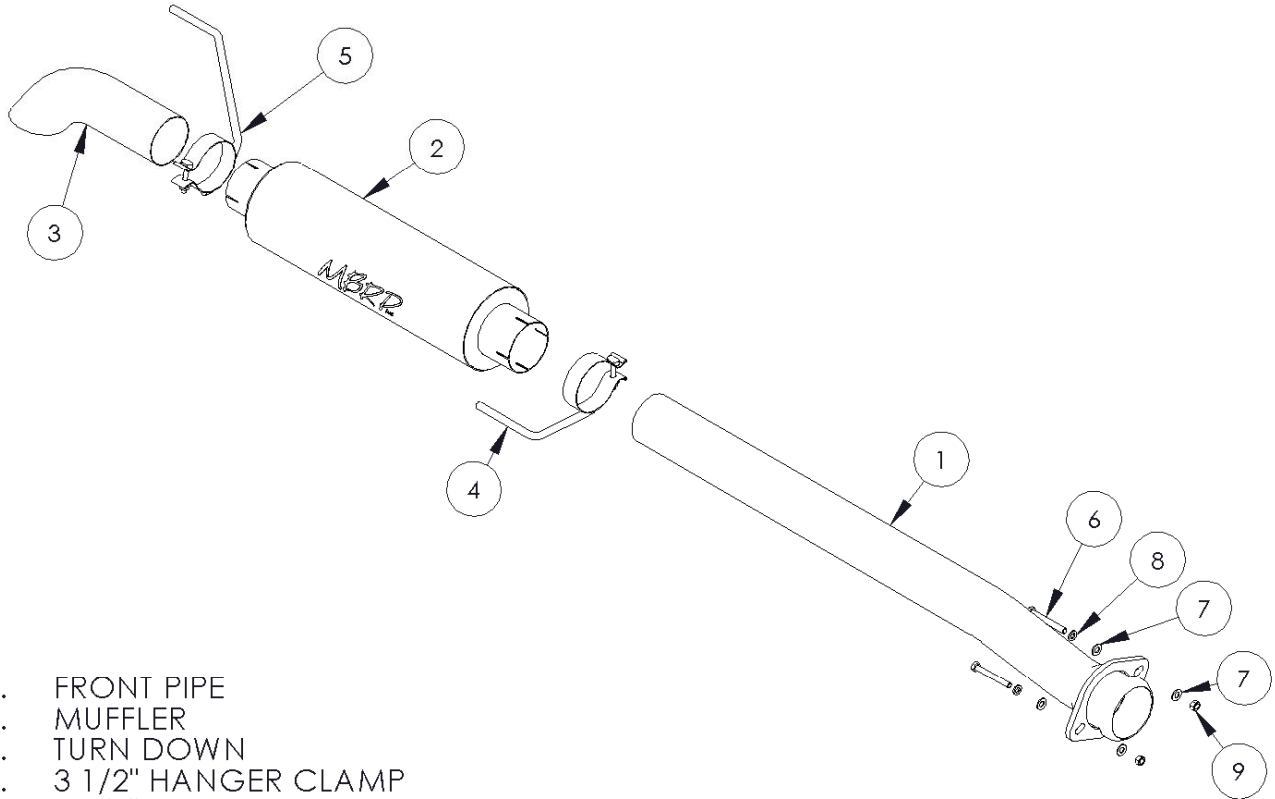

1. FRONT PIPE
2. MUFFLER
3. TURN DOWN
4. 3 1/2" HANGER CLAMP
5. 3 1/2" HANGER CLAMP
6. 3/8" X 3" HEX BOLT (2PCS)
7. 3/8" FLAT WASHER (4PCS)
8. 3/8" LOCK WASHER (2PCS)
9. 3/8" HEX NUT (2PCS)

NOTE: SADDLE CLAMPS USED IN
ALUMINIZED SYSTEM

PLEASE READ BEFORE STARTING INSTALLATION

While MBRP Inc. has made every effort to ensure that all components of this system are of superior quality and properly packaged, it is the installer's responsibility to ensure the following before removal of the factory exhaust:

- that ALL components shown above are present.
- that ALL mating components fit together.
- that there are no damaged components.
- that the system you have purchased is appropriate for your vehicle year, model and configuration.
- that the system will not interfere with any modifications previously installed or planned.
- that you have read and understand these instructions.

If you have any questions or are uncertain about any aspect of the installation of this system to your vehicle please contact your dealer before commencing installation.



Removal of Stock System:



Figure 1

1. Apply a penetrating lubricant liberally to all exhaust fasteners, hangers and rubber insulators.

2. Loosen the flange located behind the “Y” pipe.
Refer to Figure 1.



Figure 2

3. Loosen the clamp located in front of the muffler.
Refer to Figure 2.

4. Remove the hangers from the rubber insulators and remove the exhaust from the vehicle. If a hoist or hydraulic lift is not being used the tail pipe may need to be cut to clear the rear axle.
Refer to Figure 3.



Figure 3

Installation of MBRP Inc. Performance Exhaust:

1. Install the **Front Pipe** to the existing flange using the fasteners provided.
Refer to Figure 4.

Note; the **Front Pipe** will require trimming on some models.



Figure 4

Model	Bed Length	Wheelbase	Front Pipe Cut
SuperCab	6.5'	133"	12"
SuperCrew	5.5'	145"	



Figure 5

2. Slide the first **3 1/2” Hanger Clamp** over the **Front Pipe** and install the **Muffler** onto the **Front Pipe**. Install the **3 1/2” Hanger Clamp** into the existing rubber insulator.
Refer to Figure 5.



Figure 6

3. Slide the **Turn Down** onto the **Muffler** using the remaining **3 1/2” Hanger Clamp** then slide the hanger into the rubber isolator.
Refer to Figure 6.

4. Check along the whole length of the exhaust system to ensure that there is adequate clearance around the spare tire, fuel and brake lines or any wiring. If any interference is detected relocate or adjust.

Congratulations! You are ready to begin experiencing the improved power, sound and driving excitement of your MBRP Inc. performance exhaust system. We know you will enjoy your purchase.