



AUTOMOTIVE PRODUCTS, INC.

## INSTALLATION INSTRUCTIONS

HDX RUNNING BOARDS

APPLICATION: FORD F150 2004-14 SUPER CAB/SUPER CREW

PART # 57-53515, 57-53525, 57-52365

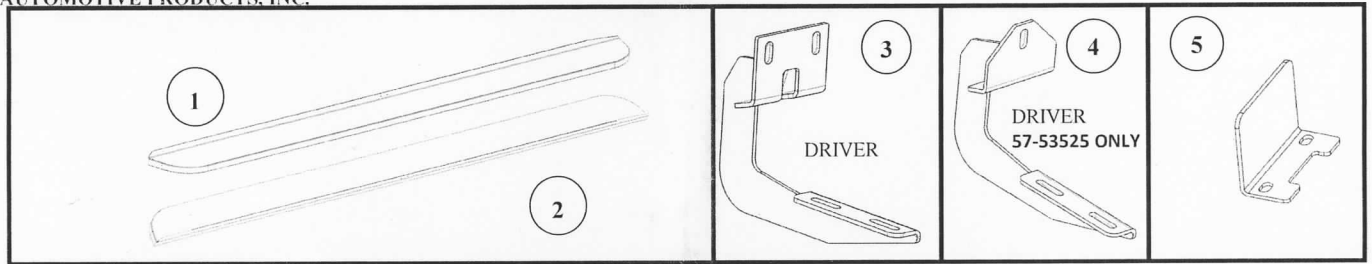

| ITEM | QUANTITY | DESCRIPTION  | TOOLS NEEDED      |
|------|----------|--|-------------------|
| 1    | 1        | RUNNING BOARD PASSENGER  | 13MM SOCKET       |
| 2    | 1        | RUNNING BOARD DRIVER   | 13MM WRENCH       |
| 3    | 6        | MOUNTING BRACKETS - 3 DRVR./3 PASS.<br>P# 57-53525 WILL HAVE QTY. OF 4 ONLY.- 2 DRVR/2 PASS.                 | RATCHET           |
| 4    | 2        | CENTER BRACKET 1 DRVR.-1 PASS.<br>THESE BRACKETS WILL BE IN P# 57-53525 KIT ONLY. FOR 09-14 F150 SUPER CREW. | RATCHET EXTENSION |
| 5    | 2        | BOOT SCRAPER   | TORQUE WRENCH     |
| 6    | 36       | M8 HEX HEAD BOLT   | 5/16" DRILL BIT   |
| 7    | 36       | M8 24MM Flat Washer  | TRANSFER PUNCH    |
| 8    | 36       | M8 LOCK WASHER   | SILICONE          |
| 9    | 24       | M8 U-NUT   |                   |
| 10   | 12       | M8 16MM FLAT WASHER  |                   |
| 11   | 12       | M8 HEX NUT   |                   |
| 12   | 4        | M9.5 External Tooth Lock Washer  |                   |
| 13   | 4        | M9.5 Hex Head Self Tap Screw   |                   |

**ANTI-SEIZE LUBRICANT MUST BE USED ON ALL STAINLESS STEEL FASTENERS TO PREVENT THREAD DAMAGE AND GALLING .**

- Remove contents from box, verify if all parts listed are present and free from damage. Carefully read and understand all instructions before attempting installation.
- Identify driver and passenger side running boards and install M8 u-nut clips (Item 9) to the underside of the boards. **Figure 1.**
- Starting on the drivers side rocker panel, locate a piece of black tape. Remove the tape to reveal a rectangle hole. Take (2) M8 nut clips (item 9) and place them over the two round holes located vertically into the rocker panel. **Figure 3.**
- Take the drivers side front mounting bracket (item 3), and attach it to the previously installed nut clips using (2) M8 hex head bolts (item 6), (2) M8 lock washers (item 8), and (2) M8 large flat washers (item 7). Do not fully tighten at this time, the cradles will face the rear of the vehicle. **Figure 4.**
- Attach the mounting bracket to the bottom holes in the rocker panel using (2) M8 hex head bolts (item 6), (2) M8 large flat washers (item 7), (2) M8 flat washers (item 10), (2) M8 lock washers (item 8), and (2) M8 hex nuts (item 11). Do not fully tighten at this time. **Figures 4 & 6.**
- Repeat steps 3-5 for the center and rear mounting brackets.
- For **09-14 Super Crew p/n 57-53525**, the center brackets will mount only using (1) M8 nut clip (item 9). **Figure 5.**
- Take the drivers side running board and place it onto the mounting bracket cradles; align the running board with the mounting holes in the brackets and attach using (6) M8 hex head bolts (item 6), (6) M8 lock washers (item 8), and (6) M8 large flat washers (item 7) **Figure 2.** Do not fully tighten at this time.
- Align and adjust the running board as needed then fully tighten all hardware at this time. Torque all M8 hardware to 20 ft lbs.
- Repeat steps 3-8 for the passenger side.



Westin Automotive Products, Inc.  
320 Covina Blvd  
San Dimas, Ca. 91773

Thank You for choosing Westin products  
For Additional installation assistance please call  
Customer service (800) 793-7846  
www.westinautomotive.com

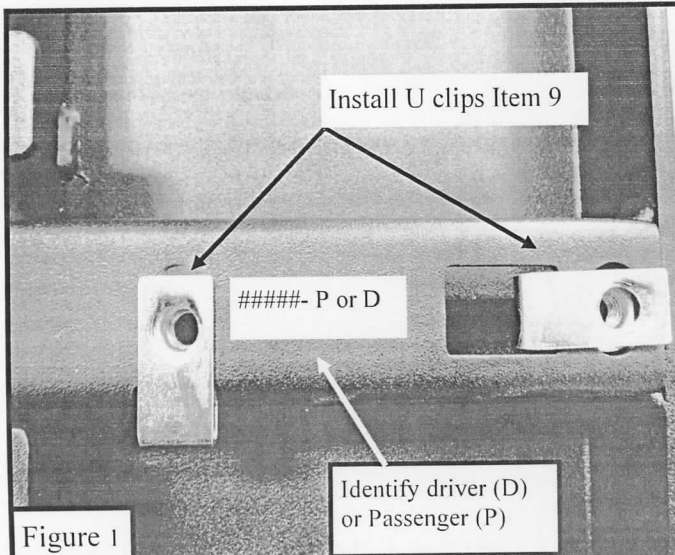

Figure 1

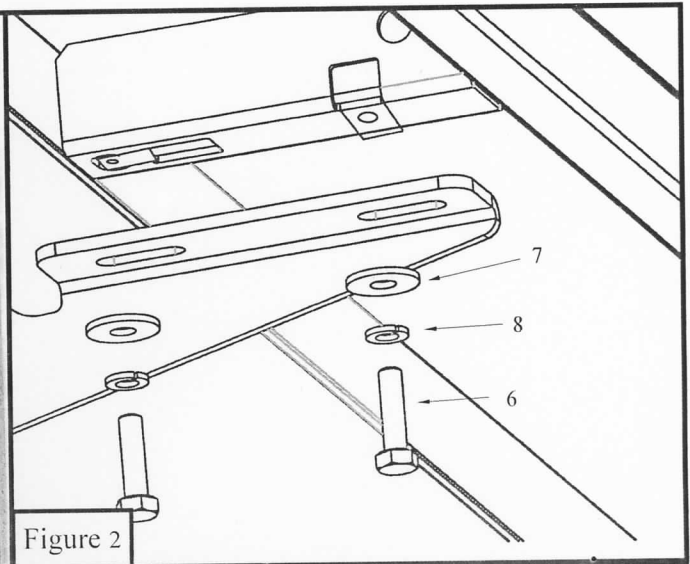

Figure 2

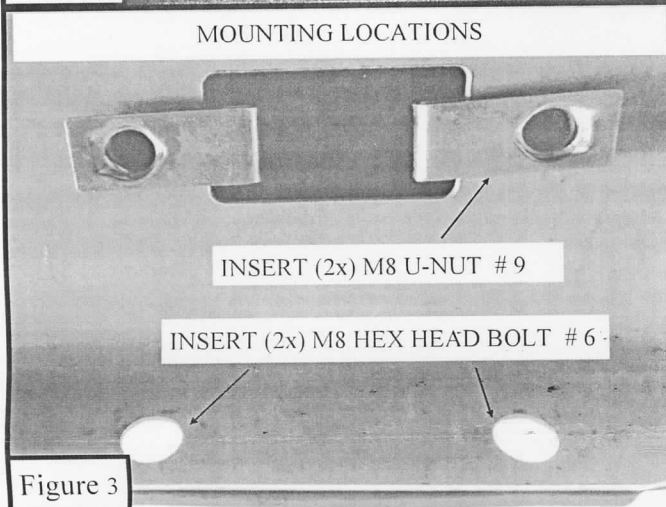

Figure 3

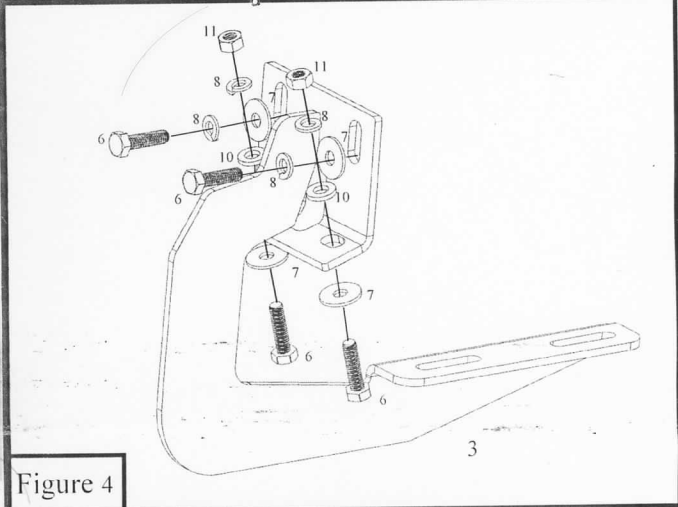

Figure 4

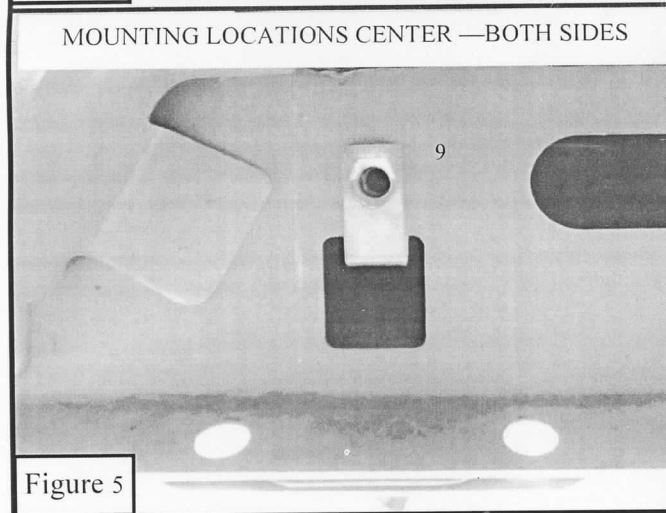

Figure 5

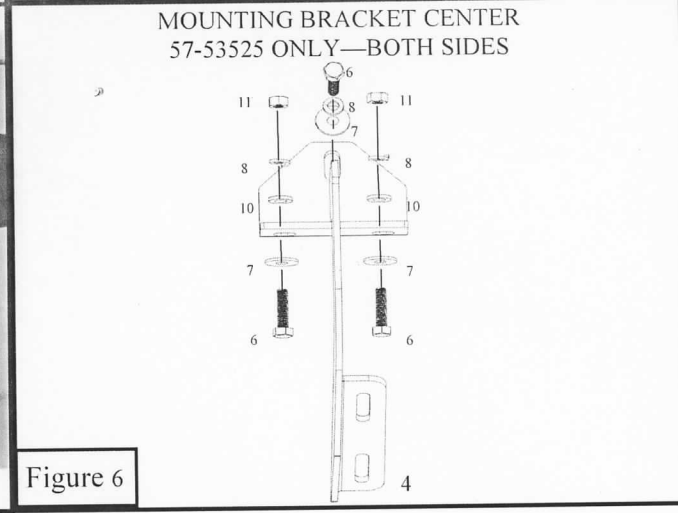

Figure 6



Westin Automotive Products, Inc.  
320 Covina Blvd  
San Dimas, Ca. 91773

P.N.: 75-0115-RevA ECO #: W14-0030

Thank You for choosing Westin products  
For Additional installation assistance please call  
Customer service (800) 793-7846  
www.westinautomotive.com

DATE: 04/15/2014

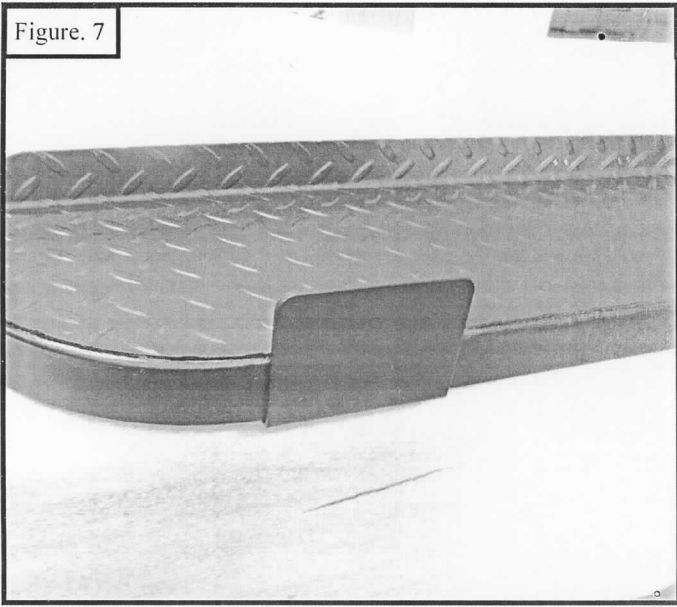

Figure. 7

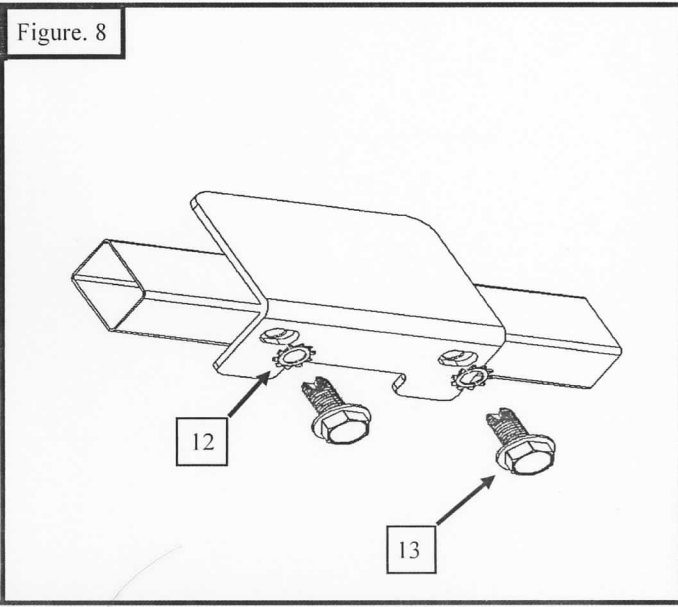

Figure. 8

**Boot scraper (OPTIONAL)** can be installed anywhere on the underside front edge of the running board. Place the boot scraper (item 5) on the underside of the running board rail. Then mark the position that it will be installed using a transfer punch. Remove the boot scraper; then using a 5/16" drill bit align it with the previously made marks and drill through the bottom of the rail on the running board. Thread in (2x) 9.5mm hex head self tapping screws. Remove the screws and add some silicone sealant in the holes to prevent rust. Attach the boot scraper (item 5) using (2x) 9.5mm Hex Flange Head Self Threading Screw (item 13) and (2x) 9.5mm external toothed lock washers (item 12). (Figure 8 ) Torque all M9.5 hardware to 18 ft. lbs.

Installation complete

