

# AMP RESEARCH BedStep2™

Congratulations on your purchase of the genuine AMP Research BedStep2™. Here's what you should know...



## BEDSTEP2™ OPERATION

The AMP Research BedStep2™ is foot operated and deploys and retracts with a nudge of your foot. To deploy, press down using your foot, on the outside edge of the step pad. Maximum load capacity of the deployed step pad is 300 lbs. Always use appropriate hand holds when stepping up to or down from your truck's cargo bed.



To retract, gently kick up on the underside of the step pad.



**MAINTENANCE TIPS** - The stepping surface and linkage should be periodically washed with mild soap and water using a soft brush or sponge to dislodge any mud, dirt or accumulated road grime. **In severe driving conditions, pressure washing the linkage is strongly recommended.** Do not apply silicone spray, waxes or protectants like Armor All® to the stepping surfaces.

**CAUTION! BEDSTEP2™ SHOULD ALWAYS BE STOWED IN THE RETRACTED POSITION WHEN DRIVING.**

## AMP RESEARCH LIMITED WARRANTY

AMP RESEARCH warrants this product to be free from defects in material and workmanship for THREE (3) YEARS FROM DATE OF PURCHASE, provided there has been normal use and proper maintenance. This warranty applies to the original purchaser only. All remedies under this warranty are limited to the repair replacement of the product itself, or the repair or replacement of any component part thereof, found by the factory to be defective within the time period specified. The decision to repair or replace is wholly within the discretion of the manufacturer.

This warranty specifically excludes labor. If you have a warranty claim, first you must call our factory at the number below for instructions. You must retain proof of purchase and submit a copy with any items returned for warranty work. Upon completion of warranty work, if any, we will return the repaired or replaced item or items to you freight prepaid. Damage to our products caused by accidents, fire, vandalism, negligence, misinstallation, misuse, Acts of God, or by defective parts not manufactured by us, is not covered under this warranty.

ANY IMPLIED WARRANTIES OF MERCHANTABILITY AND/OR FITNESS FOR A PARTICULAR PURPOSE CREATED HEREBY ARE LIMITED IN DURATION TO THE SAME DURATION AND SCOPE AS THE EXPRESS WRITTEN WARRANTY. OUR COMPANY SHALL NOT BE LIABLE FOR ANY INCIDENTAL OR CONSEQUENTIAL DAMAGE.

Some states do not allow limitations on how long an implied warranty lasts, or the exclusion or limitation of incidental or consequential damages, so the above limitations or exclusions may not apply to you. This warranty gives you specific legal rights, and you may also have other rights that vary from state to state.

**FOR WARRANTY ISSUES WITH THIS PRODUCT PLEASE CALL AMP RESEARCH CUSTOMER SERVICE 1-888-983-2204**

## WARNING

Be sure to read and precisely follow the provided instructions when installing this product. Failure to do so could place the vehicle occupants in a potentially dangerous situation. After installing or reinstalling, re-check to insure that the product is properly installed.

# AMP RESEARCH BedStep2™

Ford F150  
2015 - 2016  
(Fits 5.5 Bed)

AMP PART # 75412-01A

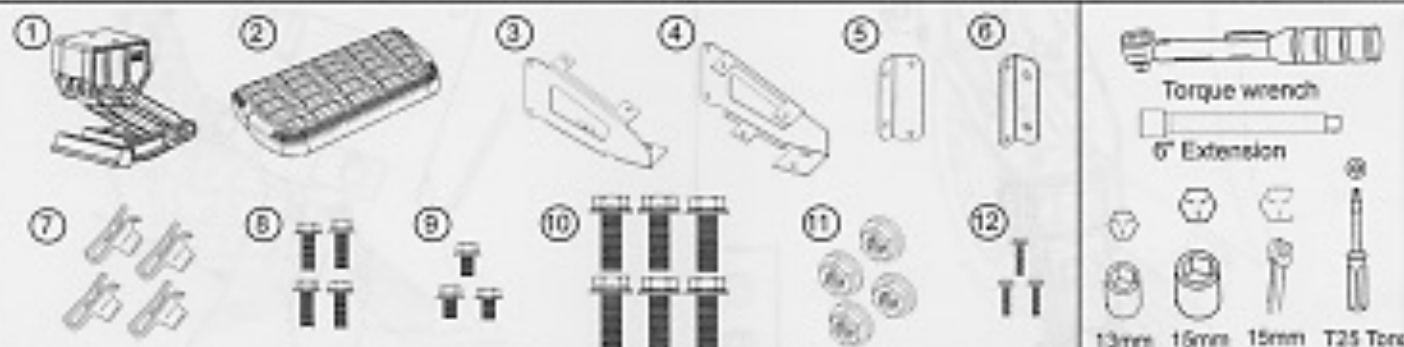

**PLEASE REFER TO PIN # 79412 FOR THE 6.5FT BED INSTALL**

Preview of final assembly... Driver Side and Passenger Side will be assembled differently, resulting in mirror images of one another.



1

**Main Bracket Assembly**... On Driver side, bolt Left Main Bracket (3) over Right Main Bracket (4) and hand tighten all three (9) M8 Bolts (2 on top, 1 on bottom).

**L Bracket Assembly**... On Driver Side, bolt Left Main Bracket (3) to L Bracket (5) and bolt Right Main Bracket (4) to L Bracket (5) using 4 M8 bolts (8).

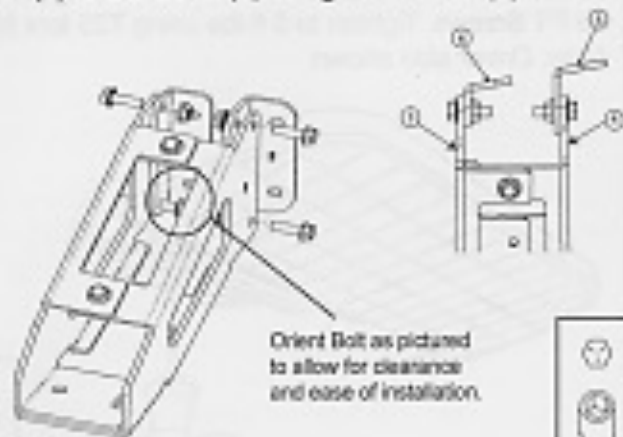
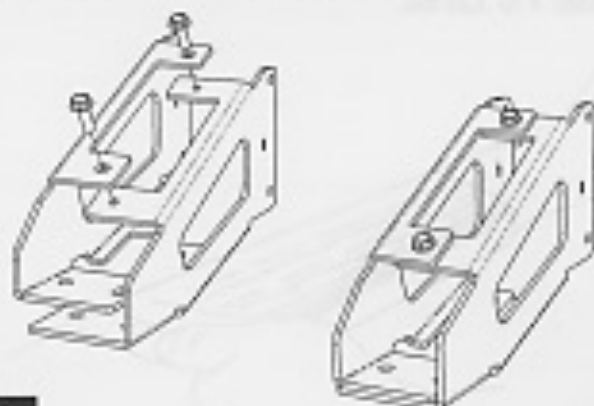

2

3

AMP RESEARCH TECH SUPPORT 1-888-983-2204 (Press 2) Monday - Friday.

BedStep2™ is invented, designed, engineered and manufactured exclusively by AMP Research and may be covered by one or more patents. AMP Research, 10000 E. North Ave., Suite 100, Detroit, MI 48213. 800.888.257; 6.938.909; 7.055.899; 7.388.667; 7.398.985; 7.584.975. Made in USA. © 2011 AMP Research. Three-year limited warranty. Professional installation is recommended.

Assemble bracket to linkage assembly using M10 Bolts. Tighten just enough to be able to swivel assembly back and forth.

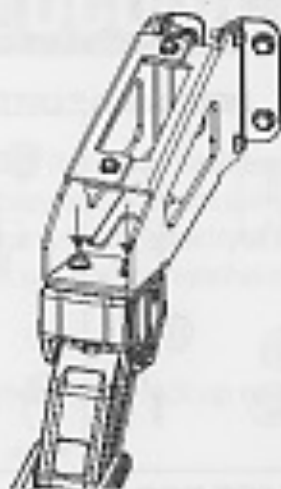

4



15mm

Insert four U clips into cutouts in frame. Be careful not to drop U clips in frame.

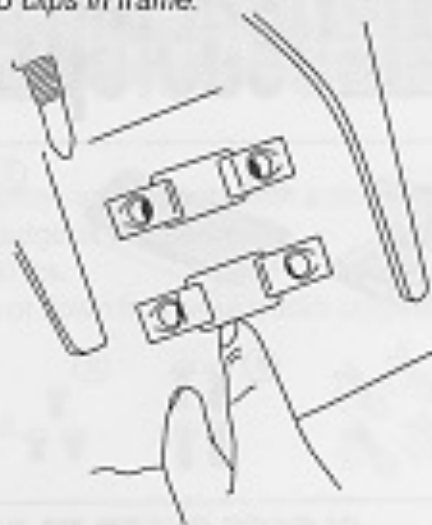

5

Set assembly in place and tighten 4 M10 bolts to the frame using a 15mm socket. Torque bolts to 33 ft-lbs. *Note: Extension may be needed to access bolts.*

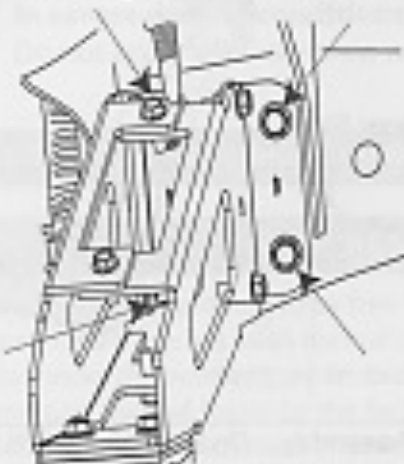

6



15mm

When assembly is secured to frame, proceed to tightening 3 M8 bolts shown below to 20ftlbs.

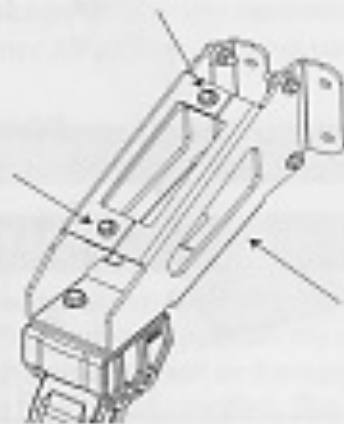

7



13mm

Offset the step pad forward and secure using provided PT Screws. Tighten to 5 ft-lbs using T25 torx bit. *Note: Driver side shown*



8



T25 Torx

Adjust step pad to be in line with fender and torque bolts from Step 4 to 33ft-lbs.



9

To deploy the step, press down using your foot on the outside edge of the step pad.



10

To retract, gently kick up on the underside of the step pad.



11