



**ROUSH**<sup>®</sup>  
P E R F O R M A N C E

- FOR OFF ROAD USE ONLY -

## **2015+ Ford F-150 Off Road Exhaust Kit**

P/N: 1115-5E292ORR

**OFF ROAD USE ONLY**

### **Installation Instructions**

Before installing your ROUSH Performance Product(s), read through the entire installation procedure and check to make sure all items are present. Contact ROUSH Customer Service at 1-800-59-ROUSH, weekdays from 9:00 AM to 5:00 PM EST, with any questions regarding fit, missing parts or instructions that are unclear to you.



**ROUSH**<sup>®</sup>  
P E R F O R M A N C E

- FOR OFF ROAD USE ONLY -

### PACKAGING LIST FOR OFF ROAD EXHAUST KIT

Description	Part Number	Qty
Flange and pipe to connect to factory	1115-5G267	1
Front Inlet Pipe	1115-5246	1
Muffler	1115-5230	1
Over-Axle Pipe	1115SE-5C262	1
Y Pipe for Tips	1115SE-5255	1
Tips	1113SE-5230TIP	2
Exhaust Clamp Kit	1115-EXCLMPKIT	1
Tip Clamps	10-0338	2
Pipe Clamps	10-0439	4
Y Pipe Hanger Bracket	1111-5A204	1



**ROUSH**<sup>®</sup>  
P E R F O R M A N C E

- FOR OFF ROAD USE ONLY -

---

### **EQUIPMENT AND SUPPLIES REQUIRED**

- Metal Cutting device (Band Saw, Hack Saw, Cut off Wheel)
- Ratchet with Extensions
- Metric Socket Sets (deep recommended)
- Torque Wrench



**ROUSH**<sup>®</sup>  
P E R F O R M A N C E

- FOR OFF ROAD USE ONLY -

## **LIMIT OF LIABILITY STATEMENT**

The information contained in this publication was accurate and in effect at the time the publication was approved for printing and is subject to change without notice or liability. ROUSH Performance Products (RPP) reserves the right to revise the information presented herein or to discontinue the production of parts described at any time.

## **SAFETY REQUIREMENTS**

**STOP!** READ IMPORTANT SAFETY CAUTIONS AND WARNINGS BEFORE PROCEEDING.

### **IMPORTANT SAFETY NOTICE**

Appropriate disassembly, assembly methods and procedures are essential to ensure the personal safety of the individual performing the kit installation. Improper installation due to the failure to correctly follow these instructions could cause personal injury or death. Read each step of the installation manual carefully before starting the actual installation.

1. Always wear safety glasses for eye protection.
2. Place ignition switch in the OFF position.
3. Always apply the parking brake when working on a vehicle.
4. Chock the front and rear tires to prevent unexpected vehicle movement.
5. If working without a lift, always consult vehicle manual for correct lifting specifications.
6. Operate the engine only in well-ventilated areas to avoid exposure to carbon monoxide.
7. Do not smoke or use flammable items near or around the fuel system.
8. Use chemicals and cleaners in well-ventilated areas.
9. Batteries produce explosive gases, which can cause personal injury. Therefore, do not allow flames, sparks or flammable substances to come near the battery.
10. Keeps hands and any other objects away from the radiator fan blades.
11. Keep yourself and your clothing away from moving parts when the engine is running.
12. Do not wear loose clothing or jewelry that can get caught in rotating parts or scratch surface finishes.
13. Allow the engine, cooling system, brakes and exhaust to cool before working on a vehicle.

### **WORK SAFELY!**

Perform this installation on a good clean level surface for maximum safety and with the engine turned off.



- FOR OFF ROAD USE ONLY -

## **SECTION A – DISASSEMBLY**

The following section will guide you through the disassembly and removal of the stock components. Longer wheelbase trucks will also have an intermediate pipe (not shown) between the factory resonator and the muffler.

1. Remove the two bolts that secure the intermediate pipe and resonator to the catalyst pipe. Set these fasteners aside as they will be re-used.
2. Loosen the clamps, which secure the intermediate pipe and resonator to the muffler and tail pipes.
3. Remove the hanger in the center of the truck at the rear of the muffler. This will aid in removing and installing the exhaust components



4. Remove the intermediate pipe and resonator from the vehicle.
5. Slide each of the hangers out of the rubber hangers and remove the factory muffler / tail pipe assembly from the vehicle.





- FOR OFF ROAD USE ONLY -

## **SECTION B – ASSEMBLY**

The following section will guide you through the assembly and installation of the ROUSH components.

1. Loosen the rear spring support bracket bolt so you have a gap of about 7 – 10mm of threads showing.

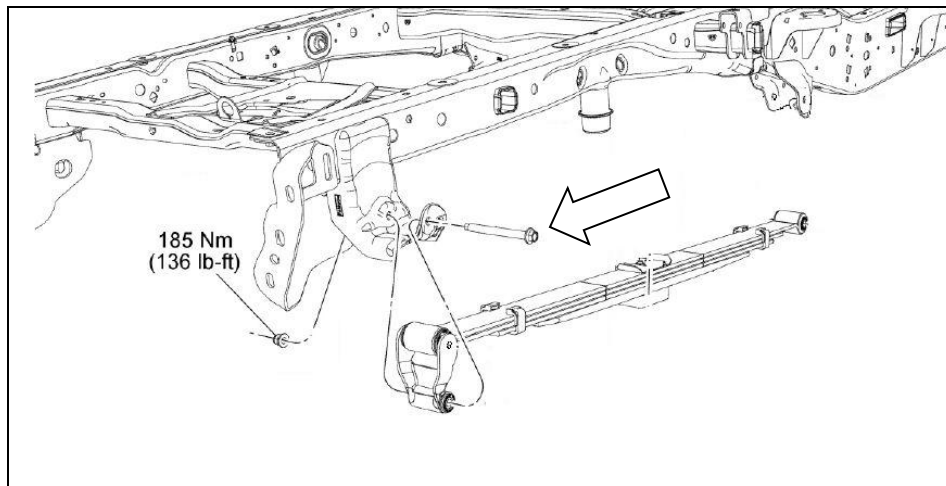



- FOR OFF ROAD USE ONLY -

2. Position the new catalyst pipe adapter flange into place against the catalyst pipe and loosely install the two take out fasteners to hold it in place.
3. Position the new muffler outlet axle pipe into position and install the steel hanger brackets into the factory rubber hangers. Orient the pipe such that the flared end faces forward in vehicle. At this time re install the hanger bracket that was removed in step 3 of the disassembly section.
4. Insert one (1) 3" clamp over the outlet end of the new muffler assembly and slide this into the end of the muffler outlet pipe, position the clamp on the joint and loosely secure.
5. At the end of this document there is a list of the cut lengths for this intermediate pipe. Be sure to leave enough length for engagement into the catalyst pipe flange. Mark the pipe and double check BEFORE cutting to ensure it will be cut correctly.

**NOTE: THIS INTERMEDIATE PIPE HAS TO BE CUT TO LENGTH PRIOR TO FINAL INSTALLATION TO FIT YOUR PARTICULAR VEHICLE WHEELBASE**

6. Remove the intermediate pipe and cut the pipe at the marked length to fit your wheelbase. Make sure to double check your measurement prior to cutting the material. Cut off the end **OPPOSITE** the hanger that is welded to the pipe, remove all sharp edges after cutting.
7. Re-install the pipe assembly to the catalyst flange. Loosely install the two fasteners.





**ROUSH**<sup>®</sup>  
P E R F O R M A N C E

- FOR OFF ROAD USE ONLY -

8. Install one (1) 2.5" clamp onto each of the exhaust tips and slide the tips onto the ends of the Y-pipe. Position the clamps on the pipe joints and loosely secure the clamps.
9. Insert one (1) 3" clamp over the end of the new Y-Pipe Assembly and slide into position on the end of the muffler outlet pipe.
10. Insert the Y-pipe hanger into the hanger bracket. It is important to note the orientation of the bracket as it will hang underneath the suspension bracket.
11. Slide the new rear tailpipe support bracket between the head of the bolt and the frame and re-torque the bolt to 185 Nm. When torquing the leaf spring bolt this must be done with the truck on the ground not on a hoist. The truck must be under its own weight.  
\* **NOTE: IF the bracket does not slide over the suspension bolt it is necessary to open the slot with a file or sanding wheel. This task should be done using caution to not remove too much material. The bracket should be snug on the bolt for installation when done correctly.**



12. With the full system now hanging in the truck, make sure all of the hangers are fully seated and there are no clearance issues with vehicle parts contacting the exhaust system.
13. With the system in the desired position, torque all four 3" clamp joints to 50 Nm.
14. Torque the two catalyst adapter bolts to 44 Nm.
15. Torque the two 2.5" clamps on the tips to 50 Nm.





- FOR OFF ROAD USE ONLY -

16. On the eco-boost truck there are 2 hangers at the muffler. The most forward hanger can be removed. As shown below. Store this with your stock take off exhaust.





**ROUSH**  
P E R F O R M A N C E

- FOR OFF ROAD USE ONLY -

**Congratulations!!!** You have completed the installation of your new ROUSH Performance Products, F-150 Off Road Exhaust Kit. It is recommended that you save all parts removed from your vehicle during the installation of this kit.

### Cut Lengths per wheelbase

**122.4 wheelbase (19.6 inches)**

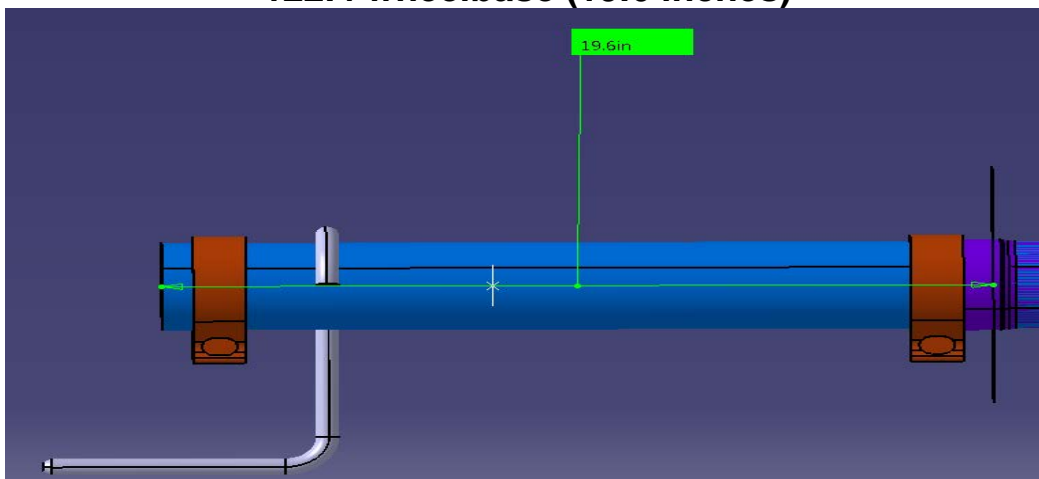

**141.1 wheelbase (38.3 inches)**

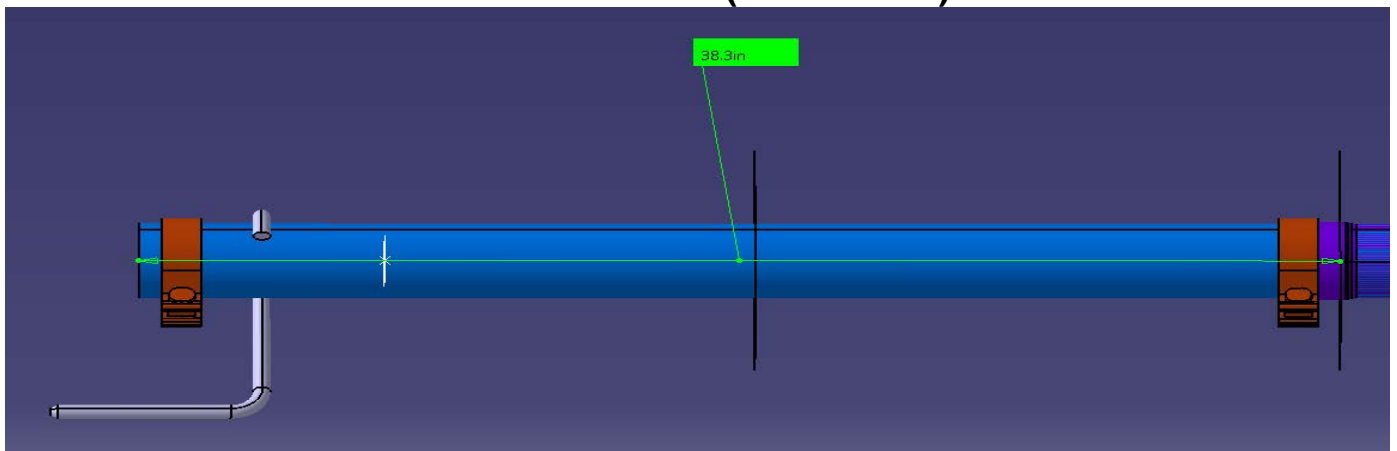



**ROUSH**  
P E R F O R M A N C E

- FOR OFF ROAD USE ONLY -

**145 wheelbase (42.2 inches)**

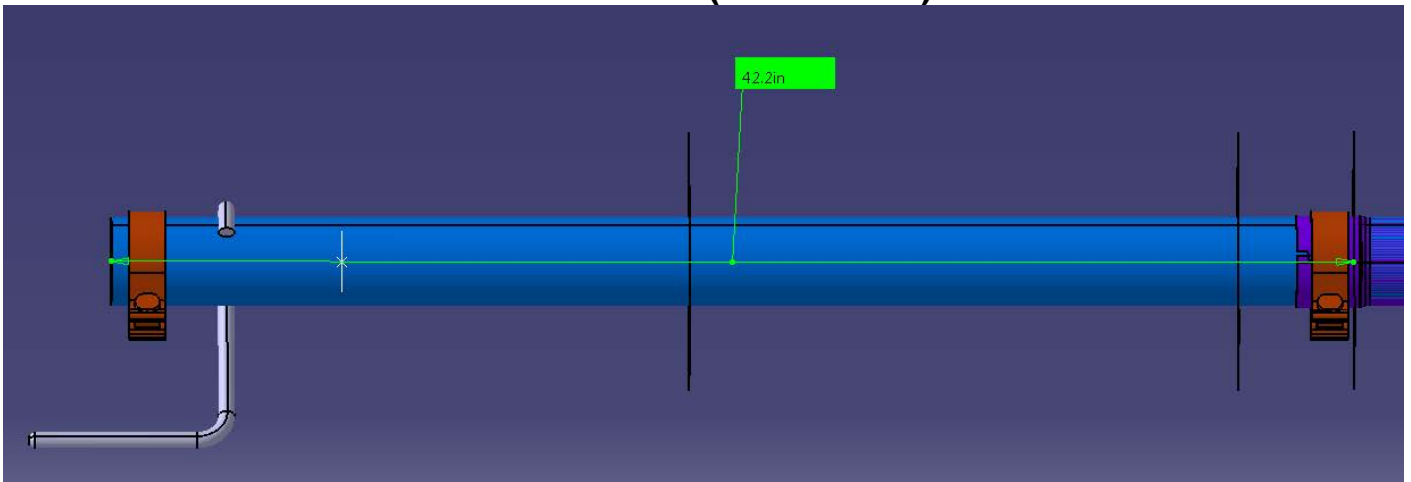

**156 wheelbase (54 inches)**

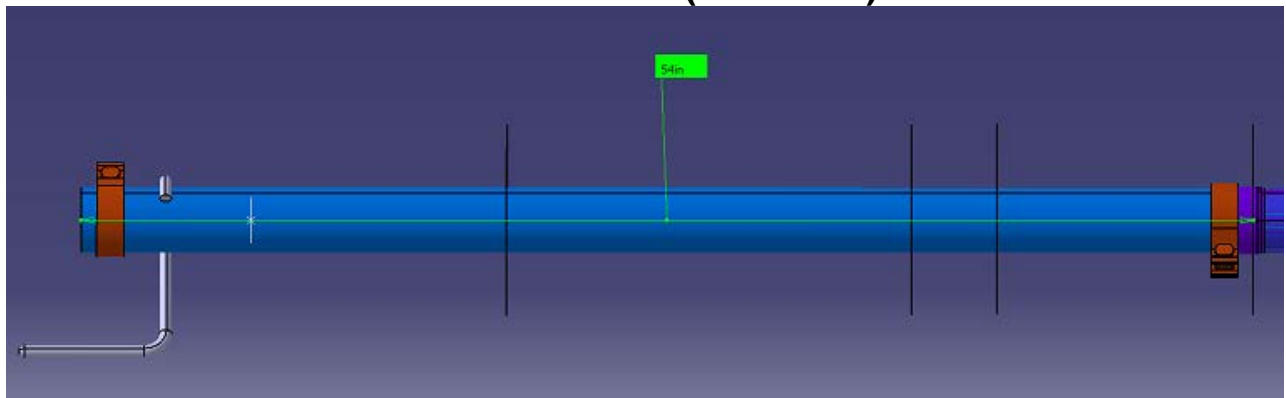

**163.7 wheelbase (no cut for this wheelbase)**

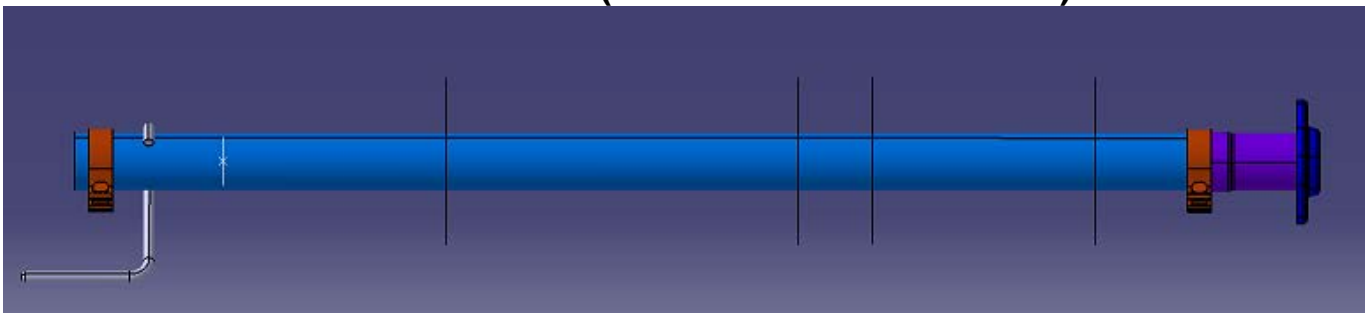



- FOR OFF ROAD USE ONLY -

## **WARRANTY**

All retail parts carry a 90-day warranty from the date of purchase. This warranty covers defects in materials or workmanship, and does not include (i) normal wear and tear, environmental conditions, improper installation; (ii) road hazards, misuse, abuse, neglect, accidents, collision, fire, theft, freezing, vandalism, riot, explosion, or objects striking the vehicle; (iii) misusing the vehicle, such as driving over curbs, overloading, racing, or using the vehicle as a stationary power source; (iv) altering, disassembling or modifying the parts; (v) defects caused or induced by failures, breakdowns, or damage by other parts, components or the vehicle; (vi) subjecting the parts to excessive moisture or water or any motor vehicle fluids (e.g.: oil, anti-freeze, battery acid, brake fluid, etc.); (vii) acts of God, natural disasters and other similar causes beyond the reasonable control of ROUSH; or (viii) application of chemicals that affect the parts. This Limited Warranty does not cover surface deterioration of paint, trim, and appearance items that result from use and/or exposure to the elements, such as stone chips, scratches, bird droppings, lightning, hail, windstorm, dings, dents, earthquake, road salt, tree sap, water or flood.

ROUSH SHALL NOT BE LIABLE TO REIMBURSE CUSTOMER/DEALER FOR INCIDENTAL OR CONSEQUENTIAL DAMAGES RESULTING FROM THE INSTALLATION OR USE OF ANY PRODUCT SOLD THROUGH THIS CATALOG OR ARISING OUT OF ANY BREACH OF WARRANTY. EXCEPT AS MAY BE STATED IN THIS CATALOG, ROUSH DISCLAIMS ALL EXPRESS AND IMPLIED WARRANTIES, INCLUDING THE WARRANTIES OF MERCHANTABILITY AND FITNESS FOR A PARTICULAR PURPOSE. IN NO EVENT SHALL ROUSH'S LIABILITY EXCEED THE PRICE PAID BY CUSTOMER/DEALER FOR PRODUCTS SOLD REGARDLESS IF ROUSH HAS BEEN ADVISED IN ADVANCE OF ANY POTENTIAL PROBLEM OR IF A CLAIM IS BASED ON CONTRACT, TORT, STRICT LIABILITY, PRODUCT LIABILITY OR OTHERWISE. SOME STATES DO NOT ALLOW THE EXCLUSION OR LIMITATION OF IMPLIED WARRANTIES OR THEIR DURATION, OR LIABILITY FOR INCIDENTAL OR CONSEQUENTIAL DAMAGES, SO THE ABOVE EXCLUSIONS OR LIMITATIONS MAY NOT APPLY.