

2015-2017 Ford F-150 Level 2 Performance Pack

Installation Instructions

P/N: 422010



ROUSH
PERFORMANCE

2015-2017 F-150 Level 2 Performance Pack

Installation Instructions

P/N: 422009 (1 1 1 550-PWRPK1-AA)

Application: 2015-2017 Ford F-150 5.0L

Important Note:

Before installing the ROUSH Performance Product, please read through the installation procedure and verify that all items are present. If you are missing hardware or have any questions, please contact ROUSH Performance at 1-800-59-ROUSH, 9:00 AM to 5:00 PM EST.

TABLE OF CONTENTS

Packing List for F-150 5.0L Cold Air Intake3
Equipment and Supplies Required.....3
Limit of Liability Statement.....4
Safety Precautions4
Work Safely!4
Section A – Removal5
Section B – Installation.....7

PACKING LIST FOR F-150 5.0L COLD AIR INTAKE

Description	Part Number	Quantity
Air Box	1115-9A612	1
Filter Tube	111550-12B579	1
Clean Air Tube	111550-9B660	1
Filter with Clamp	131550-9601R	1
Hardware Kit	111550-CAKHWK	1
Bolt (M8 x 1.25 x 25)	W500224-S437	2
Seal – Bulb Seal 25 mm CTL	1115-9B624	1
Rubber Seal Solid Round 0.5 inches	1115-9B624FOAM	1
Coupler – Air Box-to-Clean Air Tube	111550-9B661	1
Coupler – Clean Air Tube-to-Throttle Body	111550-9B662	1
PCV Fitting – 3/8"	KLR-9N285	1
PCV Fitting – 5/8"	1311-9N285	1
Grommet – 5/8" ID	1150-58GRMT	2
Clamp (110-130 mm)	R07130015-13	2
Clamp (78-100 mm)	308707426	2

EQUIPMENT AND SUPPLIES REQUIRED

- Metric 1/4" Drive Socket Set
- Flat-head Screwdriver
- Trim Tool

If you are missing any items, please call us toll free at 1-800-59-ROUSH.

LIMIT OF LIABILITY STATEMENT

The information contained in this publication was accurate and in effect at the time the publication was approved for printing and is subject to change without notice or liability. ROUSH Performance Products (RPP) reserves the right to revise the information presented herein or to discontinue the production of parts described at any time.

SAFETY PRECAUTIONS



CAREFULLY READ THE IMPORTANT SAFETY PRECAUTIONS and WARNINGS BEFORE PROCEEDING WITH THE INSTALLATION!

Appropriate disassembly, assembly methods and procedures are essential to ensure the personal safety of the individual performing the kit installation. Improper installation due to the failure to correctly follow these instructions could cause personal injury or death. Read each step of the installation manual carefully before starting the installation.

- Always wear safety glasses for eye protection.
- Place ignition switch in the OFF position.
- Always apply the parking brake when working on a vehicle.
- Block the front and rear tire surface to prevent unexpected vehicle movement.
- If working with a lift, always consult vehicle manual for correct lifting specifications.
- Operate the engine only in well-ventilated areas to avoid exposure to carbon monoxide.
- Do not smoke or use flammable items near or around the fuel system.
- Use chemicals and cleaners in well-ventilated areas.
- Batteries produce explosive gases, which can cause personal injury. Therefore, do not allow flames, sparks or flammable substances to come near the battery.
- Keeps hands and any other objects away from the radiator fan blades.
- Keep yourself and your clothing away from moving parts when the engine is running.
- Do not wear loose clothing or jewelry that can get caught in rotating parts or scratch surface finishes.
- Allow the engine, cooling system, brakes and exhaust to cool before working on a vehicle.

WORK SAFELY!

Perform this installation on a good clean level surface for maximum safety and with the engine turned off.

SECTION A – REMOVAL

The following section will guide you through the removal of the stock components. Special care should be taken to label fasteners and parts that are taken off during this procedure since many will be reused.

1. Cover both fenders with fender covers to protect the vehicle finish.
2. Disconnect the battery ground cable.
3. Remove the bolt retaining the stock air box to the inner driver side fender. Retain the bolt, sleeve and grommet for later use.



4. Loosen the hose clamps retaining the clean air tube to the throttle body and air box lid.



5. Disconnect the two (2) quick connect fittings from the clean air tube.



6. Release the two (2) clamps on the front of the air box.



7. Remove the air box lid.



8. Remove the clean air tube from the vehicle.



10. Remove the lower air box and dirty air duct from the vehicle.



9. Remove the two (2) push clips retaining the dirty air inlet duct to the grill closeout.



11. Remove the self-tapping screw retaining the dirty air inlet onto the lower air box.



12. Remove the dirty air inlet from the lower air box.

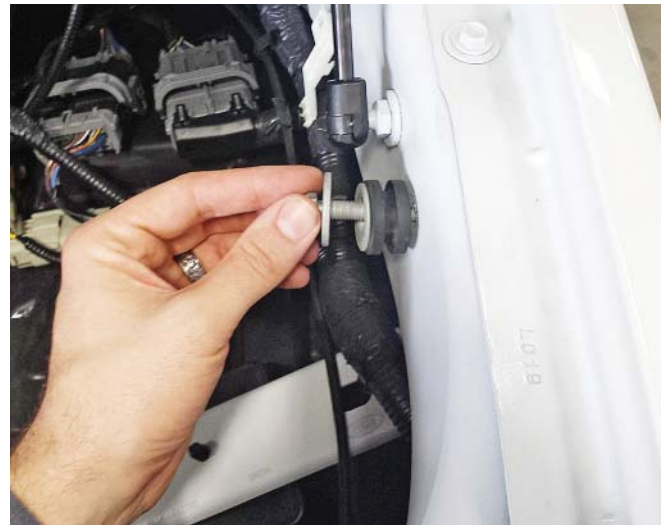

13. If necessary, remove the two (2) rubber grommets from the bottom of the air box and reinstall them into the tray below the air box.

3. Install the Roush air box (P/N: 1115-9A612) into the vehicle by locating the two (2) bosses on the bottom of the box while aligned to the grommet.

SECTION B — INSTALLATION

1. Insert the dirty air inlet into the Roush air box (P/N: 1115-9A612). Reuse the self-tapping screw that was removed earlier. Tighten to 3 Nm.



2. Reinstall the bolt, grommet and sleeve into the driver side fender. Tighten the bolt to 17.5 Nm.

4. Install the air filter (P/N: 131550-9601R) onto the filter tube (P/N: 111550-12B579) and tighten the clamp to 3 Nm. Make sure the filter is installed (as shown) with the metal rib down.



5. Slide the filter and tube assembly into the air box.

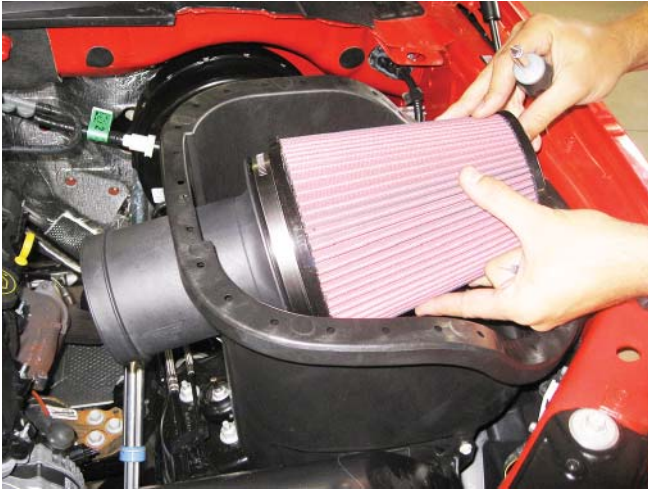

6. Install the two (2) M8 bolts (P/N: W500224-S437) and tighten to 10 Nm.

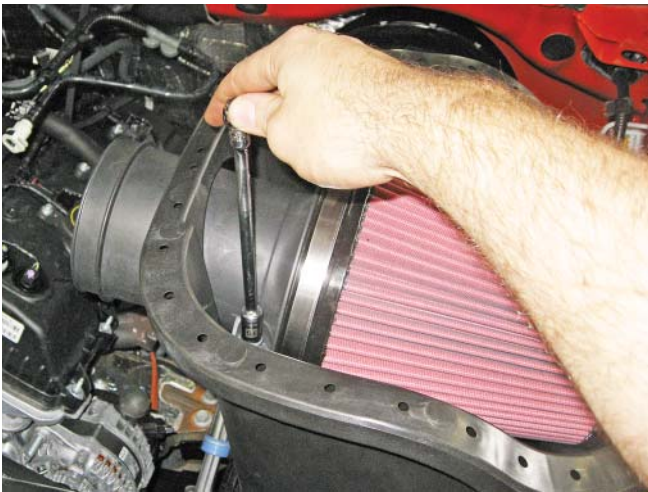

7. Install the rubber grommet (P/N: 1150-58GRMT) and fittings into the clean air tube. You will want to use soapy water or glass cleaner to aid the installation (fittings: left P/N: 1311-9N285, right P/N: KLR-9N285).



8. Install couplers and clamps onto the clean air tube (P/N: 111550-9B660) as shown. Tighten the clamps retaining the coupler to the tube to 3 Nm. Leave outside two (2) clamps loose (couplers: right P/N: 111550-9B662, left P/N: 111550-9B662) (clamps: right P/N: R07130015-13, left P/N: 308707426).

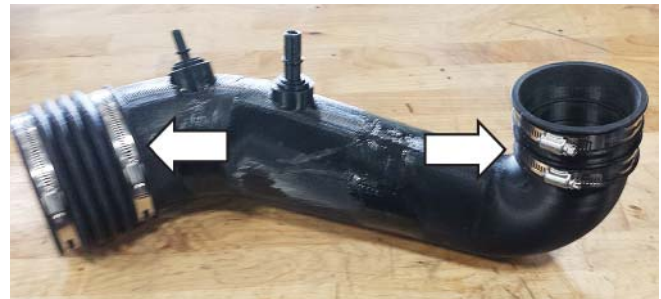

9. Install the clean air tube assembly between the throttle body and the air box. Tighten the clamps to 3 Nm.



10. Attach the two (2) quick connect hoses to the mating bars on the clean air tube.



11. Reinstall the two (2) push pins into the dirty air inlet.

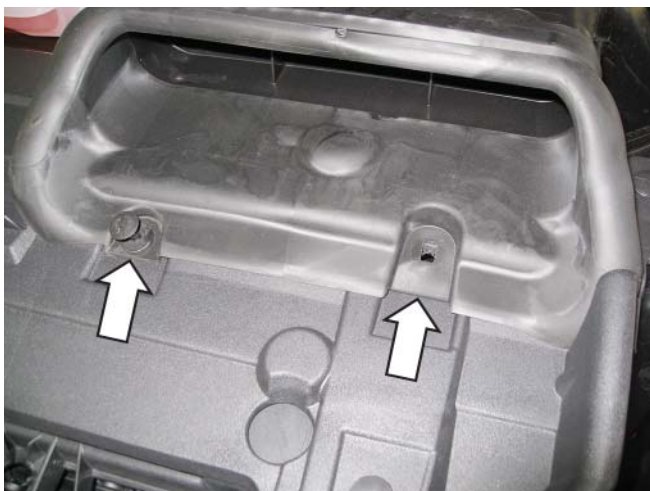

12. Insert the seal filler (P/N: 1115-9B624FOAM) halfway into the air box seal (P/N: 1115-9B624) as shown.



13. Install the air box seal starting in the location shown. You may need to trim the seal to the correct length. (Note: Start the seal at the middle of the inlet tube.)



14. The installation is now complete.



PCM FLASHING

Proceed with steps 1-2 if you have a SAE J2534 pass through device (e.g. Puma, VCM I, VCM II)

If you do not have a SAE J2534 device visit your local Roush Dealer or Performance Shop with the appropriate tools for PCM Calibration

1. If equipped with a SAE J2534 pass through device, refer to the RDT-CALIM manual found on our website. <http://rdt.roush.com> The RDT-CALIM manual will guide you through the ROUSH Diagnostic Tool (RDT) software installation process and the ROUSH PCM flashing procedure detailed in RDT-CALIM.
2. Once the PCM has been successfully recalibrated, start the engine and check for unusual noises, dash service lights, and unusual operation. If problems are detected, immediately stop the engine or vehicle, diagnose and repair the problem.

2015-2017 Ford F-150 Off-Road Exhaust Kit

Installation Instructions

P/N: 1115-5E292ORR

Application: 2015-2017 Ford F-150 – OFF-ROAD USE ONLY

Important Note:

Before installing the ROUSH Performance Product, please read through the installation procedure and verify that all items are present. If you are missing hardware or have any questions, please contact ROUSH Performance at 1-800-59-ROUSH, 9:00 AM to 5:00 PM EST.

TABLE OF CONTENTS

Packing List for 2015-2017 Ford F-150 Off-Road Exhaust Kit	3
Equipment and Supplies Required.....	3
Limit of Liability Statement.....	4
Safety Precautions	4
Work Safely!	4
Section A – Disassembly.....	5
Section B – Assembly	5
Cut Lengths per Wheelbase.....	7

PACKING LIST FOR 2015-2017 FORD F-150 OFF-ROAD EXHAUST KIT

Description	Part Number	Quantity
Flange and Pipe to Connect to Factory	1115-5G267	1
Front Inlet Pipe	1115-5246	1
Muffler	1115-5230	1
Over-Axle Pipe	1115SE-5C262	1
Y-Pipe for Tips	1115SE-5255	1
Tips	1113SE-5230TIP	2
Exhaust Clamp Kit	1115-EXCLMPKIT	1
Tip Clamps	10-0338	2
Pipe Clamps	10-0439	4
Y-Pipe Hanger Bracket	1111-5A204	1

EQUIPMENT AND SUPPLIES REQUIRED

- Metal-Cutting Device (Band Saw, Hack Saw, Cut-off Wheel)
- Ratchet with Extensions
- Metric Socket Sets (deep recommended)
- Torque Wrench

If you are missing any items, please call us toll free at 1-800-59-ROUSH.

LIMIT OF LIABILITY STATEMENT

The information contained in this publication was accurate and in effect at the time the publication was approved for printing and is subject to change without notice or liability. ROUSH Performance Products (RPP) reserves the right to revise the information presented herein or to discontinue the production of parts described at any time.

SAFETY PRECAUTIONS



CAREFULLY READ THE IMPORTANT SAFETY PRECAUTIONS and WARNINGS BEFORE PROCEEDING WITH THE INSTALLATION!

Appropriate disassembly, assembly methods and procedures are essential to ensure the personal safety of the individual performing the kit installation. Improper installation due to the failure to correctly follow these instructions could cause personal injury or death. Read each step of the installation manual carefully before starting the installation.

- Always wear safety glasses for eye protection.
- Place ignition switch in the OFF position.
- Always apply the parking brake when working on a vehicle.
- Block the front and rear tire surface to prevent unexpected vehicle movement.
- If working with a lift, always consult vehicle manual for correct lifting specifications.
- Operate the engine only in well-ventilated areas to avoid exposure to carbon monoxide.
- Do not smoke or use flammable items near or around the fuel system.
- Use chemicals and cleaners in well-ventilated areas.
- Batteries produce explosive gases, which can cause personal injury. Therefore, do not allow flames, sparks or flammable substances to come near the battery.
- Keeps hands and any other objects away from the radiator fan blades.
- Keep yourself and your clothing away from moving parts when the engine is running.
- Do not wear loose clothing or jewelry that can get caught in rotating parts or scratch surface finishes.
- Allow the engine, cooling system, brakes and exhaust to cool before working on a vehicle.

WORK SAFELY!

Perform this installation on a good clean level surface for maximum safety and with the engine turned off.

SECTION A – DISASSEMBLY

The following section will guide you through the disassembly and removal of the stock components. Longer wheelbase vehicles will also have an intermediate pipe (not shown) between the factory resonator and the muffler.

1. Remove the two (2) bolts that secure the intermediate pipe and resonator to the catalyst pipe. Set these fasteners aside as they will be re-used.
2. Loosen the clamps that secure the intermediate pipe and resonator to the muffler and tail pipes.
3. Remove the hanger in the center of the vehicle at the rear of the muffler. This will aid in removing and installing the exhaust components.



4. Remove the intermediate pipe and resonator from the vehicle.
5. Slide each of the hangers out of the rubber hangers and remove the factory muffler/tail pipe assembly from the vehicle.

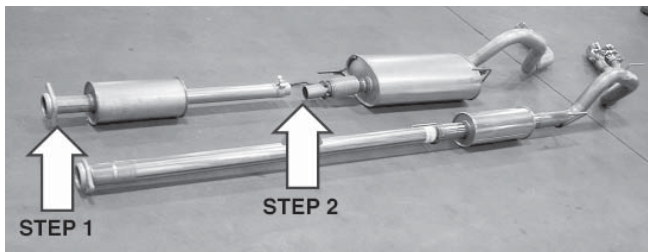

SECTION B – ASSEMBLY

The following section will guide you through the assembly and installation of the ROUSH components.

1. Loosen the rear spring support bracket bolt so that there is a gap of about 7-10 mm of threads showing.

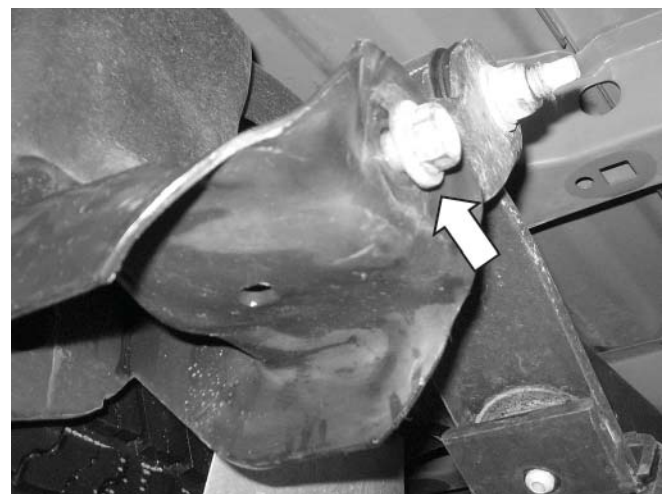
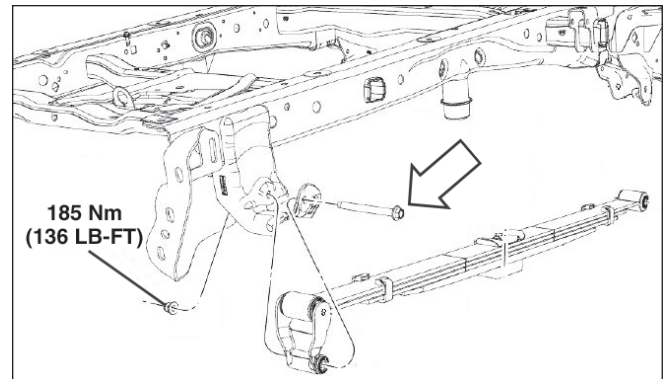

2. Position the new catalyst pipe adapter flange into place against the catalyst pipe and loosely install the two (2) take-out fasteners to hold it in place.
3. Position the new muffler outlet axle pipe into position and install the steel hanger brackets into the factory rubber hangers. Orient the pipe such that the flared end faces forward in vehicle. At this time, re-install the hanger bracket that was removed in step 3 of the Disassembly section.
4. Insert one (1) 3" clamp over the outlet end of the new muffler assembly and slide this into the end of the muffler outlet pipe. Position the clamp on the joint and loosely secure.

- There is a list of the cut lengths for this intermediate pipe at the end of this document. Be sure to leave enough length for engagement into the catalyst pipe flange. Mark the pipe and double check BEFORE cutting to ensure it will be cut correctly.

NOTE: This intermediate pipe has to be cut to length prior to final installation to fit your particular vehicle wheelbase.

- Remove the intermediate pipe and cut the pipe at the marked length to fit your wheelbase. Make sure to double check your measurement prior to cutting the material. Cut off the end OPPOSITE the hanger that is welded to the pipe. Remove all sharp edges after cutting.
- Re-install the pipe assembly to the catalyst flange. Loosely install the two (2) fasteners.

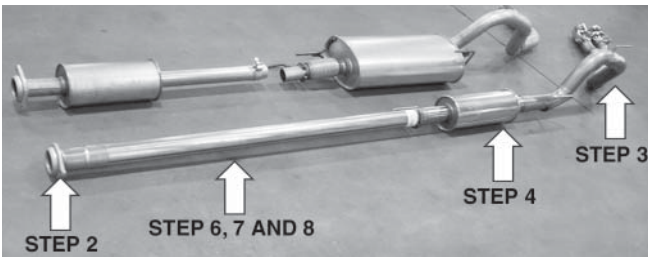

- Install one (1) 2.5" clamp onto each of the exhaust tips and slide the tips onto the ends of the Y-pipe. Position the clamps on the pipe joints and loosely secure the clamps.
- Insert one (1) 3" clamp over the end of the new Y-pipe assembly and slide into position on the end of the muffler outlet pipe.
- Insert the Y-pipe hanger into the hanger bracket. It is important to note the orientation of the bracket as it will hang underneath the suspension bracket.
- Slide the new rear tailpipe support bracket between the head of the bolt and the frame. Re-torque the bolt to 185 Nm. When torquing the leaf spring bolt, this must be done with the vehicle on the ground, not on a hoist. The vehicle must be under its own weight.



- With the full system now hanging in the vehicle, make sure all of the hangers are fully seated and there are no clearance issues with vehicle parts contacting the exhaust system.
- With the system in the desired position, torque all four (4) 3" clamp joints to 50 Nm.
- Torque the two (2) catalyst adapter bolts to 44 Nm.
- Torque the two (2) 2.5" clamps on the tips to 50 Nm.
- On the eco-boost vehicle, there are two (2) hangers at the muffler. The most forward hanger can be removed. Store this with your stock take-off exhaust.

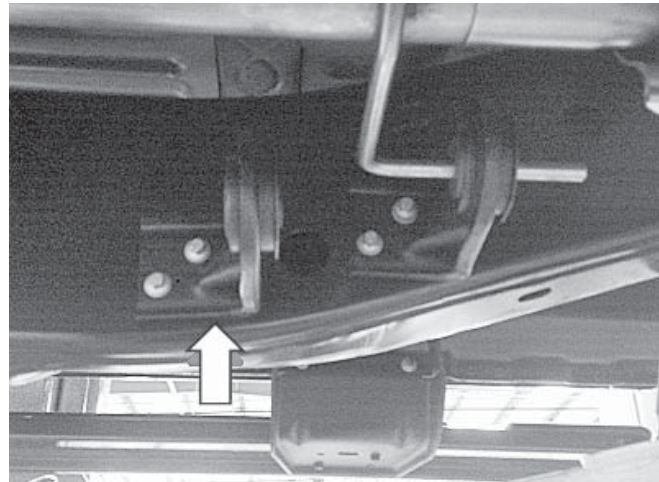

Congratulations!!! You have completed the installation of your new ROUSH Performance Products, F-150 Off-Road Exhaust Kit. It is recommended that you save all parts removed from your vehicle during the installation of this kit.

CUT LENGTHS PER WHEELBASE

122.4 wheelbase (19.6 inches)

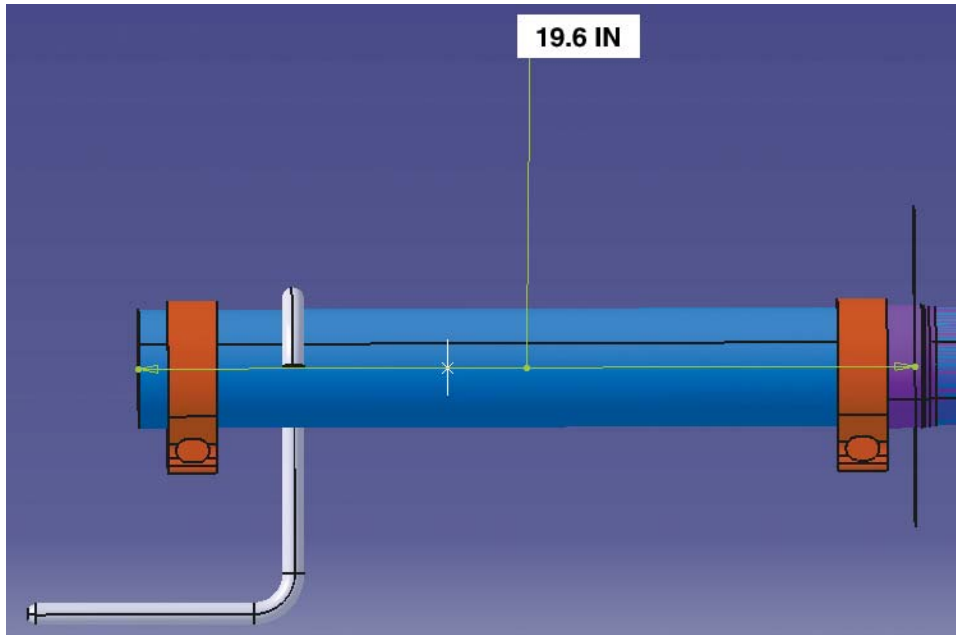

141.1 wheelbase (38.3 inches)

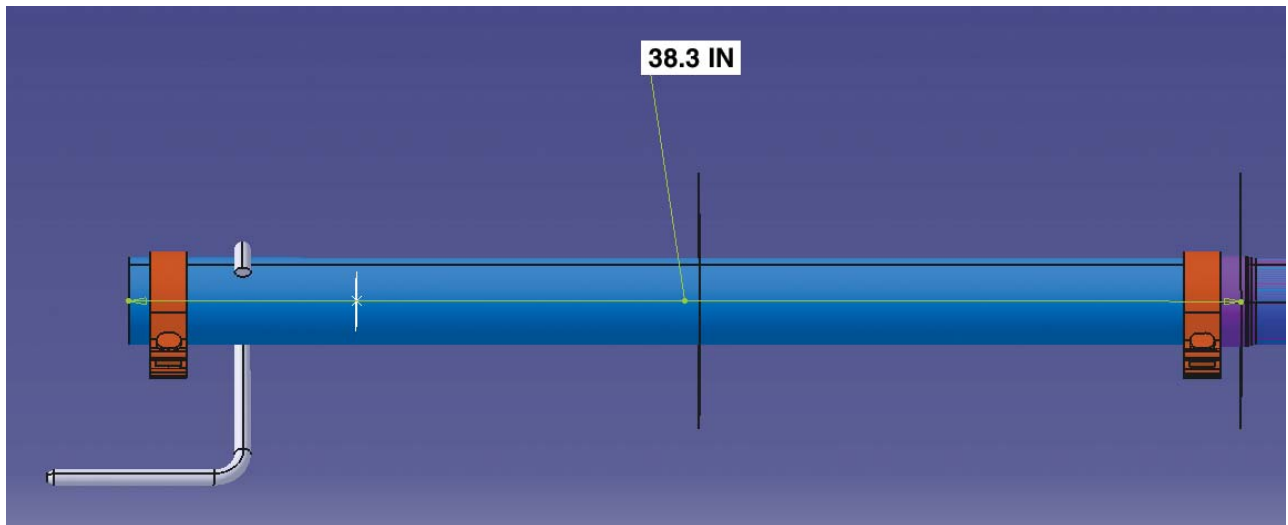

145 wheelbase (42.2 inches)

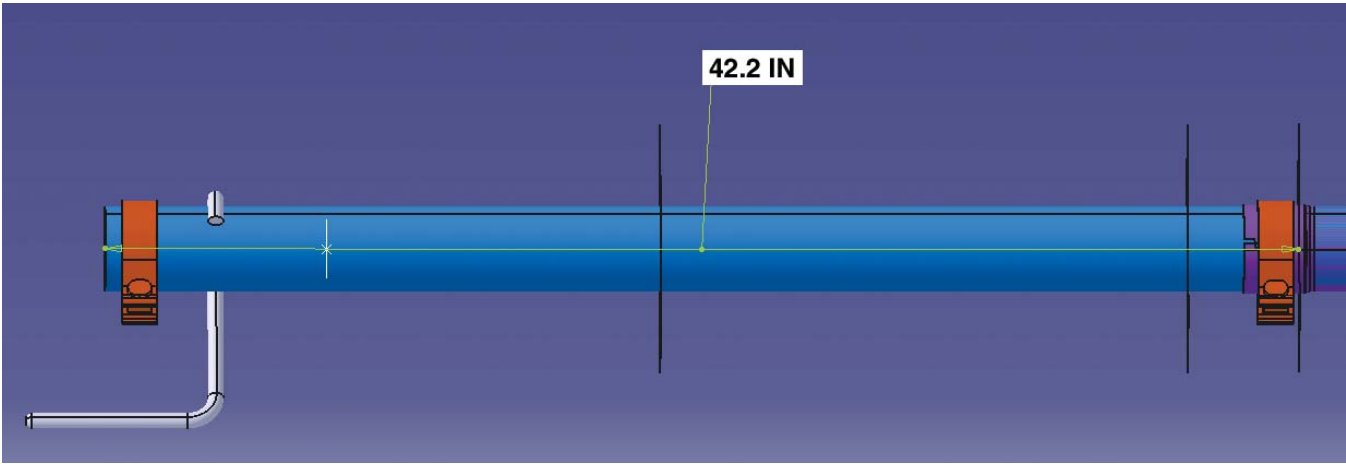

156 wheelbase (54 inches)

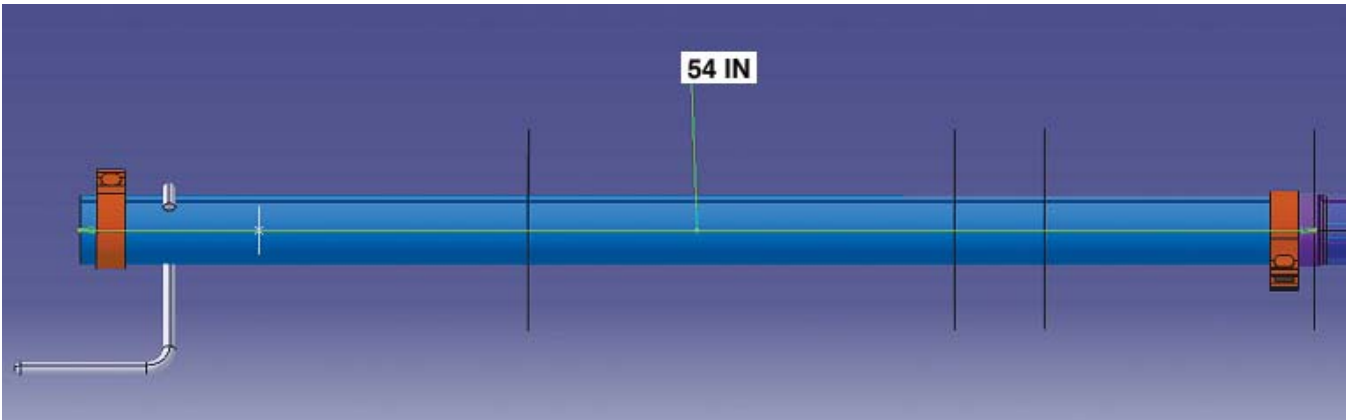

163.7 wheelbase (no cut for this wheelbase)

