

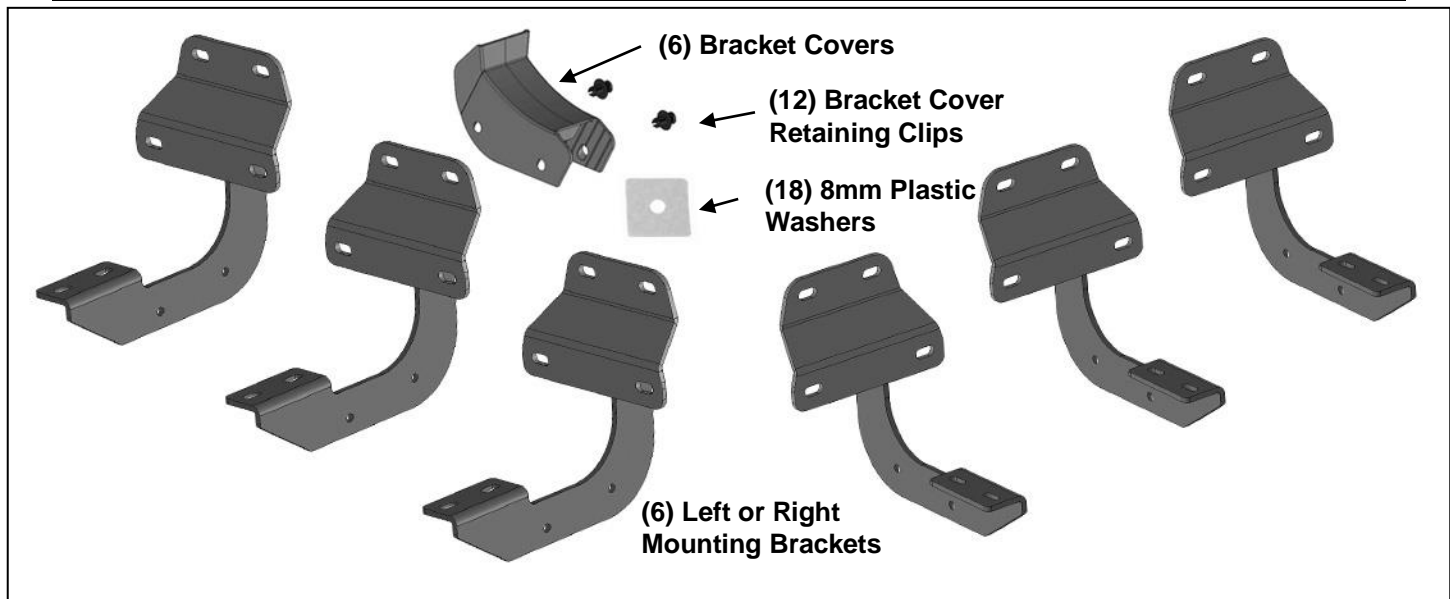

2015 F150 Super Crew Cab Aluminum Running Boards

PARTS LIST:

2	I-4 Running Boards	18	8-1.25mm Nylon Lock Nuts
6	Mounting Brackets (use for left or right)	12	6mm x 20mm T-Bolts
18	8mm Plastic Washers	12	6mm x 22mm OD x 2 mm Flat Washer
6	Plastic Covers	12	6mm Lock Washers
12	8mm Plastic Clips	12	6mm Hex Nuts
18	8mm x 24mm OD x 2mm Washers		



PROCEDURE:

REMOVE CONTENTS FROM BOX. VERIFY ALL PARTS ARE PRESENT. READ INSTRUCTIONS CAREFULLY BEFORE STARTING INSTALLATION. ASSISTANCE IS RECOMMENDED.

1. Start the installation under the driver/left side of the vehicle. Locate the front factory running board mounting location along the inner side of the body, **(Figure 1)**.
2. Slide (1) Plastic Washer over each factory mounting stud in the body panel, **(Figures 2—4)**. **IMPORTANT:** The Plastic Washers are designed to prevent corrosion between the aluminum body panel and the steel mounting brackets. **Do not install the Brackets without the Plastic Washers.**
3. Select (1) Mounting Bracket. **NOTE:** All (6) Brackets are universal and will fit left or right side. Attach the Mounting Bracket to the (3) factory studs with (3) 8mm Flat Washers and (3) 8mm Nylon Lock Nuts, **(Figures 4 & 5)**. Leave hardware loose at this time.
4. Next, select (1) Plastic Cover and (2) Cover Clips, **(Figure 6)**. Slide the Cover over the top of the Bracket and line up the (2) holes in the cover with the holes in the Bracket. Insert the Cover Clips into the holes. Push the center pin in on each clip until it is flush against the outer ring to expand the clip in the hole, **(Figures 6 & 7)**. **NOTE:** Loosen the Bracket if necessary to attach the Cover.
5. Repeat **Steps 1—4** to install the (2) remaining center and rear driver side Brackets and Covers.
6. Select (1) Running Board and (6) 6mm T-Bolts. Locate the opening in the end of each of the channels in the bottom of the Running Board. Slide (3) T-Bolts into each channel, **(Figure 8)**.

7. With assistance, carefully position the Running Board onto the (3) Mounting Brackets. Lift the Running Board up and slide the T-Bolts along the channels to line up with the Brackets.
IMPORTANT: Do not slide the Running Board on the Brackets, (front to back or rotate), or the finish on the Running Board may be damaged.
8. Line up the front of the Running Board approximately 2" back, (or locate as desired), from the front wheel opening. Attach the Running Board to the Brackets with (6) 6mm Flat Washers, (6) 6mm Lock Washers and (6) 6mm Hex Nuts, (**Figure 9**). Do not tighten hardware at this time.
9. Level and adjust the Running Board and tighten all hardware.
10. Repeat **Steps 1—9** to install the passenger/right side Running Board.
11. Do periodic inspections to the installation to make sure that all hardware is secure and tight.

To protect your investment, wax this product after installing. Regular waxing is recommended to add a protective layer over the finish. Do not use any type of polish or wax that may contain abrasives that could damage the finish. Mild soap may be used to clean the Running Boards.

Driver/left Side Installation Pictured



(Fig 1) Driver side rear mounting location



(3) Plastic Insulation Washers

(Fig 3) Thread Plastic Washers onto all mounting studs. Driver side front location pictured

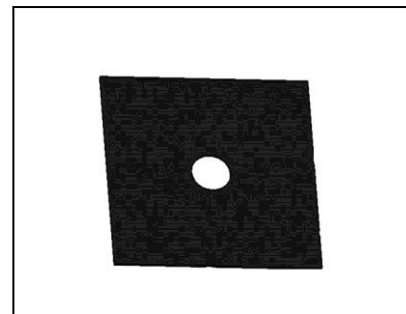

(Fig 2) Plastic Insulation Washer

(3) 8mm Flat Washers
(3) 8mm Nylon Lock Nuts

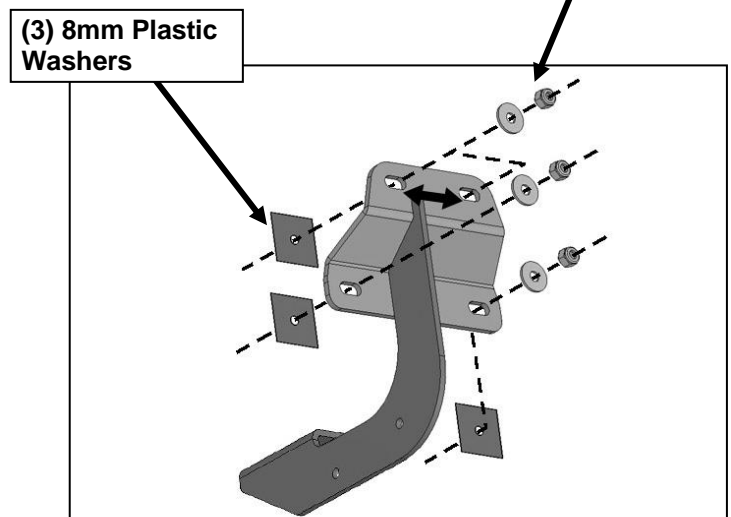

(3) 8mm Plastic Washers

(Fig 4) Driver/left side Bracket installed

Driver/left Side Installation Pictured

- (3) 8mm Plastic Washers
- (3) 8mm Flat Washers
- (3) 8mm Nylon Lock Nuts

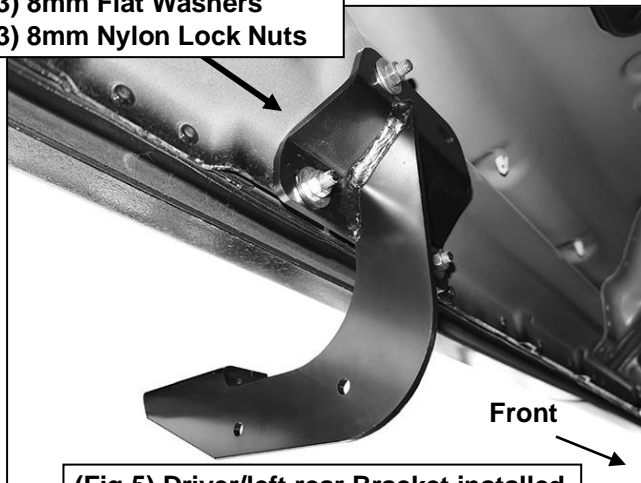

(Fig 5) Driver/left rear Bracket installed

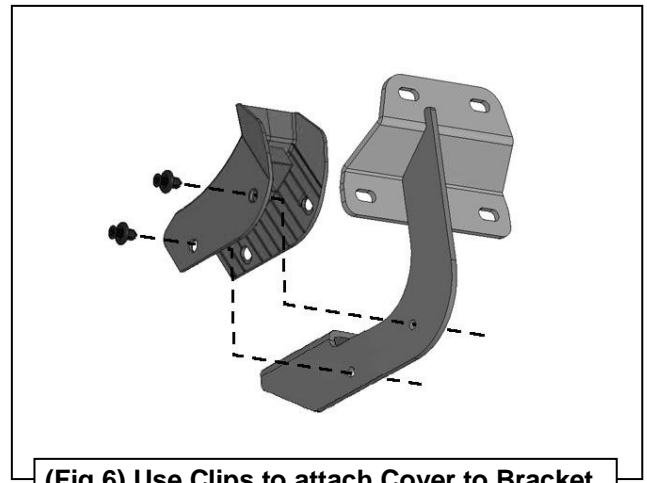

(Fig 6) Use Clips to attach Cover to Bracket

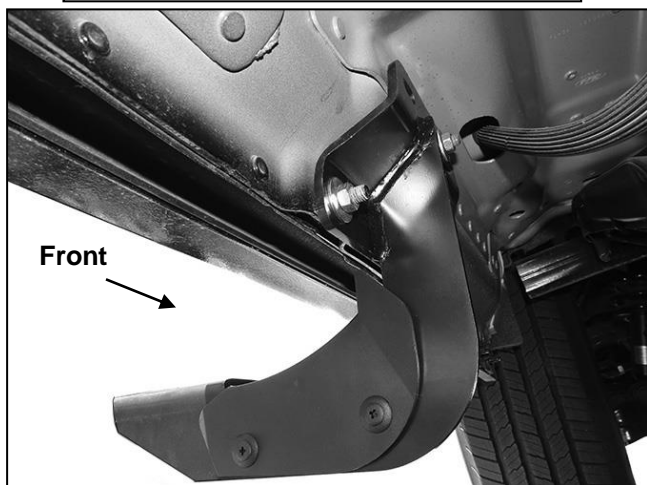

(Fig 7) Driver/left front Cover installed

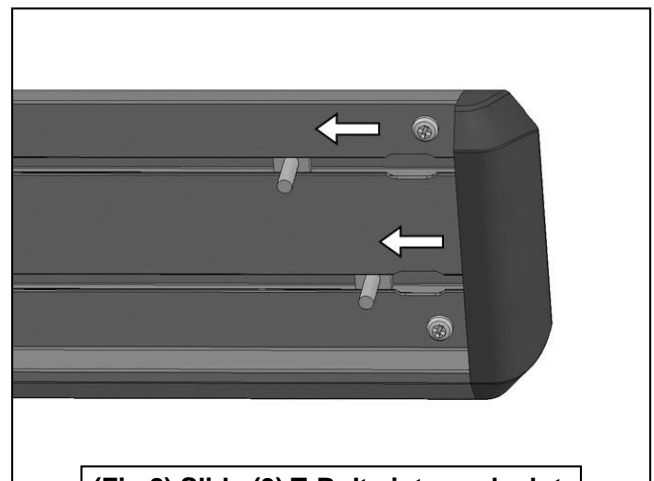

(Fig 8) Slide (3) T-Bolts into each slot

- (2) 6mm Flat Washers
- (2) 6mm Lock Washers
- (2) 6mm Hex Nuts

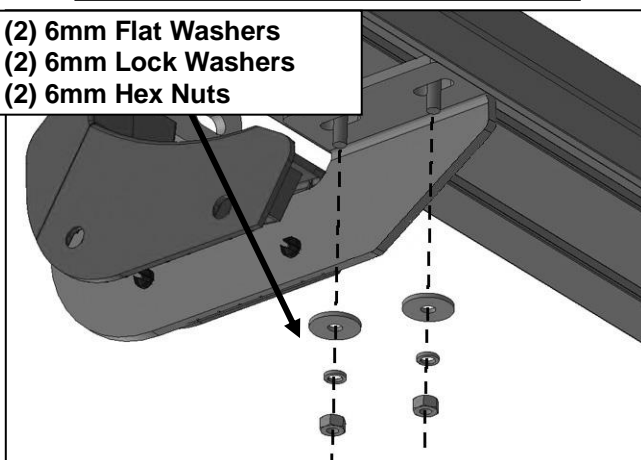

(Fig 9) Attach T-Bolts in Running Board to Bracket



Complete Installation