

3-1/2" OVAL BULL BAR
04-16 F-150

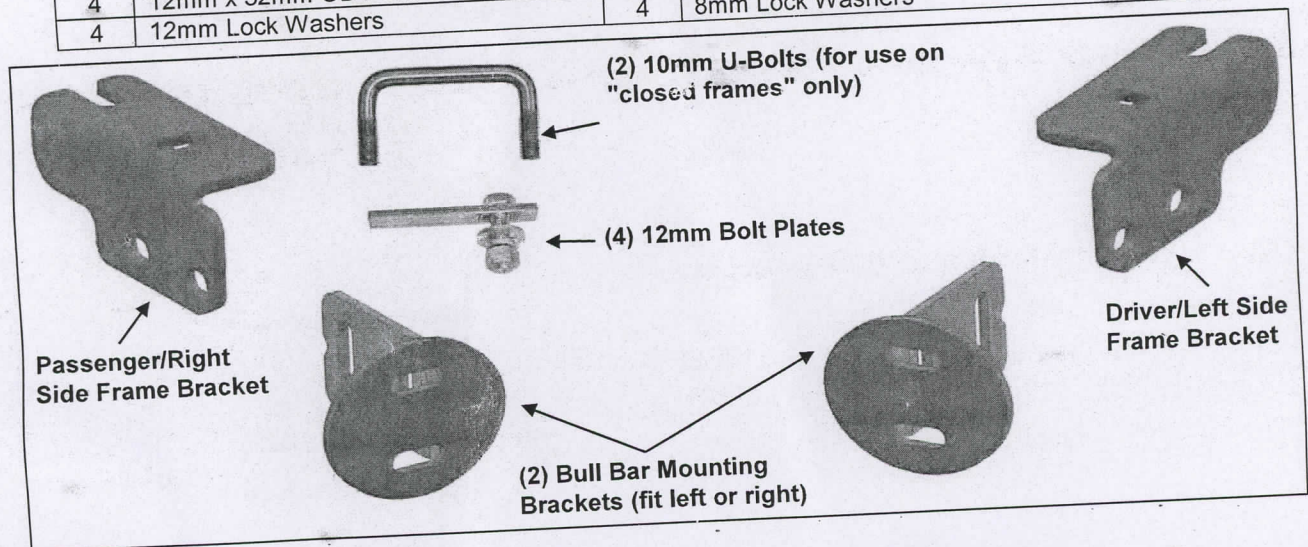


Installation Instructions

**Barricade 3.5 in. Bull Bar w/ Skid Plate & 20 in. Dual-Row LED Light Bar – Black
(Polished) (04-16 F150)
Part# T532120 T532121**

PARTS LIST:

| | | | |
|---|----------------------------------|----|-----------------------------------------------|
| 1 | 3.5in Oval Bull Bar Assembly | 4 | 12-1.75mm Hex Nuts |
| 1 | Driver side Frame Bracket | 2 | 10mm U-Bolt (for use on "closed frames" only) |
| 1 | Passenger Side Frame Bracket | 4 | 10-1.50mm x 35mm Hex Bolts |
| 2 | Bull Bar Mounting Brackets | 12 | 10mm x 27mm OD x 3mm Flat Washers |
| 4 | 12mm x 40mm Bolt Plates | 8 | 10-1.50mm Nylon Lock Nuts |
| 4 | 12mm Plastic Retainers | 4 | 8-1.25mm x 35mm Hex Bolts |
| 4 | 12mm x 32mm OD x 3mm Flat Washer | 4 | 8mm x 22mm OD x 2mm Flat Washers |
| 4 | 12mm Lock Washers | 4 | 8mm Lock Washers |



PROCEDURE:

REMOVE CONTENTS FROM BOX. VERIFY ALL PARTS ARE PRESENT. READ INSTRUCTIONS CAREFULLY BEFORE STARTING INSTALLATION. CUTTING MAY BE REQUIRED. ASSISTANCE IS RECOMMENDED. NOTE: It may be necessary to remove/relocate the front license plate and license plate bracket. It is not required, but strongly recommended. If local/state law requires a license plate, license plate relocation kit is available.

1. Determine if the vehicle is equipped with tow hooks, **(Figure 1)**.

Vehicles with Factory Tow Hooks

- Remove the driver/left tow hook by removing the front bolt and only loosening the rear bolt, **(Figure 2)**. Slide the tow hook off. Leave the rear hex bolt in place to hold the factory double nut plate in the frame and aligned with the holes. **NOTE:** Tow hooks cannot be reinstalled.
- Select the driver side Frame Bracket, **(Figure 3)**. Position the Bracket up to the bottom of the frame. Reuse the tow hook hardware to attach the Bracket to the bottom of the frame and factory double nut plate, **(Figure 4)**. Do not tighten hardware at this time.
- Repeat to install the passenger side Frame Bracket.
- Proceed to **Step 2**.

All vehicles without Tow Hooks

Remove the lower plastic portion of the bumper to gain access to the ends of the frame rails, **(Figure 5)**. The lower bumper or splash guard will need to be cut out to allow the Mounting Brackets and end of Bull Bar to pass through, **(See Step 4)**. On some models, access to the mounting hardware is limited. For access, first remove the plastic bumper cover from each side of the opening and in the center of the bumper, **(Figure 6)**.

Vehicles without Tow Hooks and open end of frame

- a. Select (1) 12mm Bolt Plate, **(Figure 7)**. Insert the Bolt Plate into the open end of the frame and down through the rear hole in the bottom of the frame, **(Figure 8)**. Thread (1) 12mm Flat Washer, (1) 12mm Lock Washer and (1) 12mm Hex Nut onto the Bolt Plate.
- b. Slide the slotted end of the driver side Bracket under the Nut and Washers.
- c. Insert (1) 12mm Bolt Plate through the remaining hole toward the front of the Mounting Bracket. Secure the Bracket to the forward Bolt Plate with (1) 12mm Flat Washer, (1) 12mm Lock Washer and (1) 12mm Hex Nut, **(Figure 8)**. Do not tighten the hardware.
- e. Repeat to install the passenger side Frame Bracket.
- f. Proceed to **Step 2**.

Vehicles without Tow Hooks, closed end of frame

- a. Locate the two holes in the bottom of the frame. Insert (1) 10mm U-Bolt into one hole and out the other, **(Figures 9 & 10)**.
 - b. Attach the driver/left Frame Bracket to the U-Bolt with (2) 10mm Flat Washers and (2) 10mm Nylon Lock Nuts, **(Figure 11)**.
 - c. Snug but do not tighten the hardware.
 - d. Repeat to install the passenger side Frame Bracket.
2. Next, carefully unwrap the Bull Bar. Select (1) Bull Bar Mounting Bracket, **(Figure 12)**. Attach the Bracket to the end of the Bull Bar with (2) 8mm x 35mm Hex Bolts, (2) 8mm Lock Washers and (2) 8mm Flat Washers. Center the mounting flange on the Bracket with the end of the tube on the Bull Bar. Snug but do not tighten hardware. Repeat this Step to install the passenger side Mounting Bracket.
3. With assistance, line up the mounting tabs on the Bull Bar with the inside of the (2) previously installed Frame Brackets. Attach the Bull Bar to the Frame Brackets with the included (4) 10mm x 35mm Hex Bolts, (8) 10mm Flat Washers and (4) 10mm Nylon Lock Nuts, **(Figures 13 & 14)**. Snug but do not tighten hardware at this time.
4. Level and adjust the Bull Bar properly and fully tighten all hardware.

Models without openings in lower bumper or splash guard for tow hooks.

- a. Hold the cover up to the bottom of the bumper, **(Figure 15)**.
 - b. Trace the location of both Brackets onto the back of the cover, **(Figure 15)**.
 - c. Temporarily remove the Bull Bar with attached Tube Brackets only. Do not remove the Frame Brackets.
 - d. Cut openings in the cover to clear the Frame Brackets and end of Bull Bar as necessary, **(Figure 16)**. For best results, start with a small slot and slowly enlarge the opening to clear the Brackets.
 - e. Once cover is properly fit to the Brackets, reinstall the cover and Bull Bar as previously described.
5. Do periodic inspections to the installation to make sure that all hardware is secure and tight.

To protect your investment, wax this product after installing. Regular waxing is recommended to add a protective layer over the finish. Do not use any type of polish or wax that may contain abrasives that could damage the finish.

For stainless steel: Aluminum polish may be used to polish small scratches and scuffs on the finish. Mild soap may be used also to clean the Bull Bar.

For gloss black finishes: Mild soap may be used to clean the Bull Bar.

Driver Side Installation Pictured

Remove tow hooks if equipped

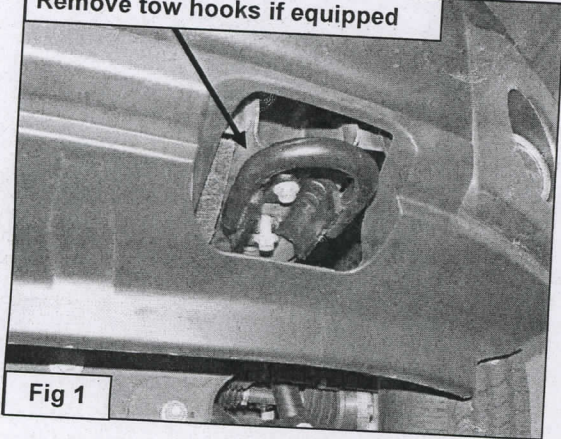


Fig 1

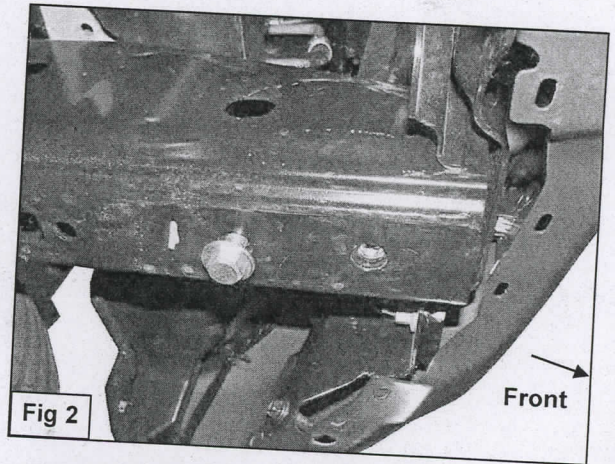
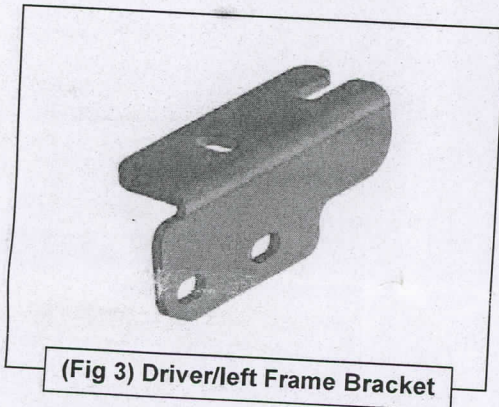
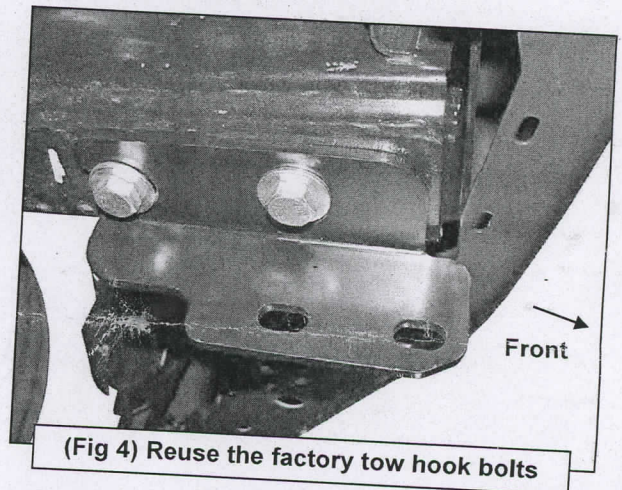


Fig 2

Front

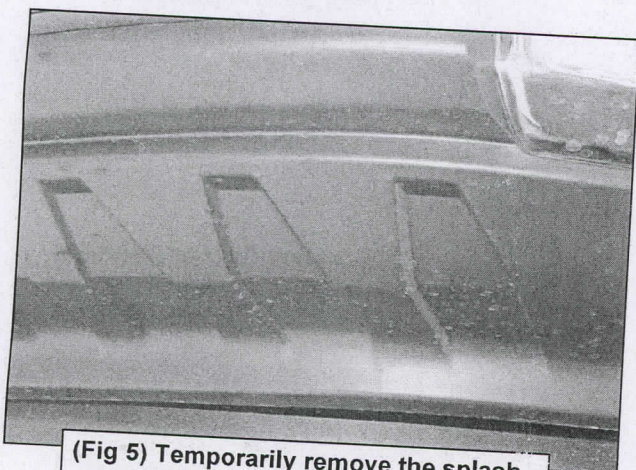


(Fig 3) Driver/left Frame Bracket

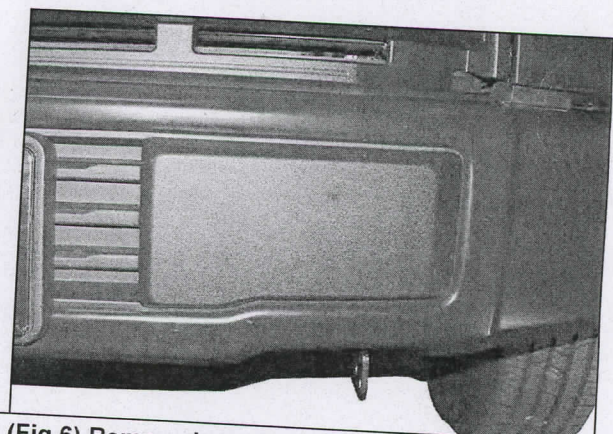


(Fig 4) Reuse the factory tow hook bolts

Front

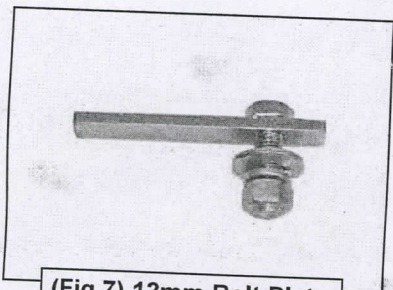


(Fig 5) Temporarily remove the splash guard as required to gain access to the front of the frame channel.



(Fig 6) Remove bumper pads to access splash guard hardware if necessary. 2015 F150 pictured

Driver Side Installation Pictured



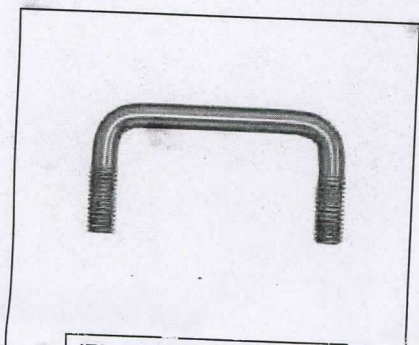
(Fig 7) 12mm Bolt Plate

Insert Bolt Plates through open end of frame

- (2) 12mm x 40mm Bolt Plates
- (2) 12mm Lock Washers
- (2) 12mm Flat Washers
- (2) 12mm Hex Nuts

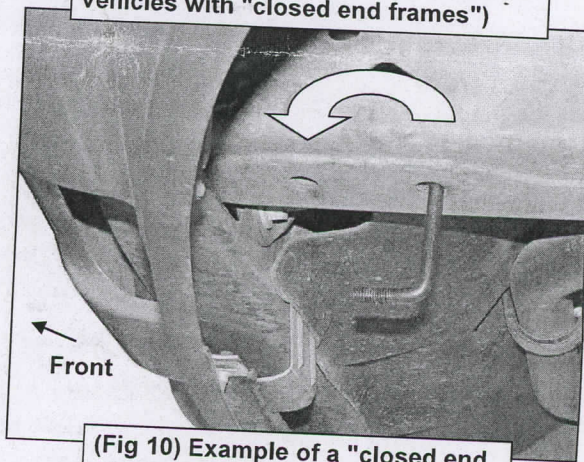


Fig 8



(Fig 9) 10mm U-Bolt

Insert 10mm U-Bolt into one hole and out the other. (U-Bolt is only used on vehicles with "closed end frames")



Front

(Fig 10) Example of a "closed end of frame" installation pictured

Example of a "closed end of frame" pictured

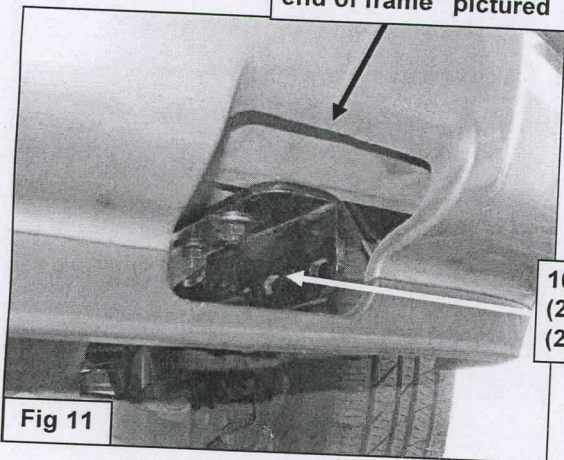
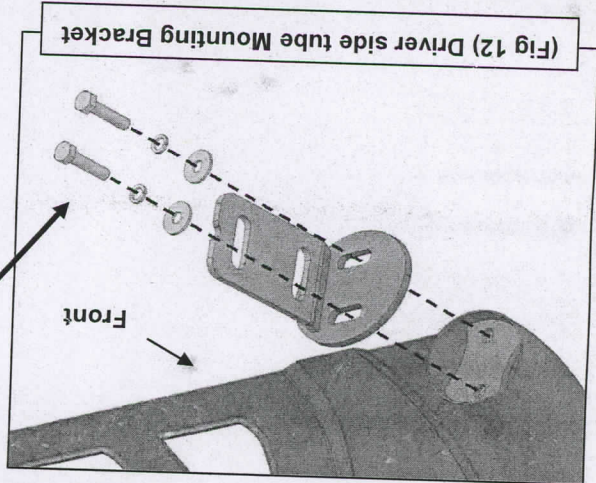


Fig 11

- 10mm U-Bolt
- (2) 10mm Flat Washers
- (2) 10mm Nylon Lock Nuts

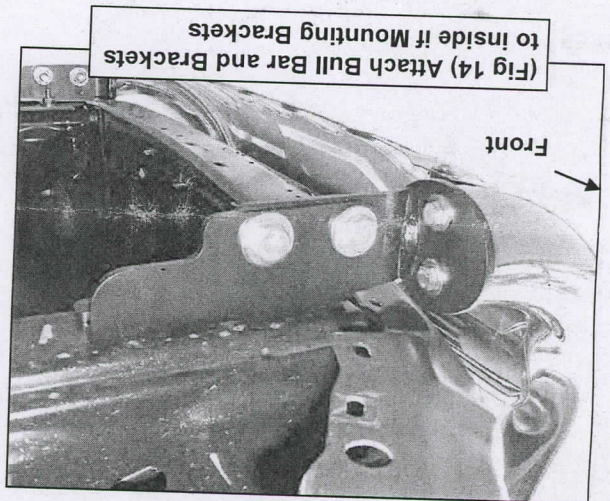
Driver Side Installation Pictured



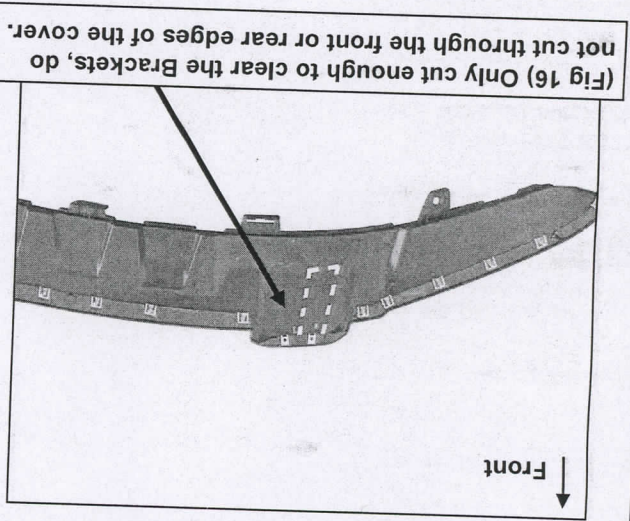
(Fig 12) Driver side tube mounting bracket

- (2) 8mm x 35mm Hex Bolts
- (2) 8mm Lock Washers
- (2) 8mm Flat Washers

- (2) 10mm x 35mm Hex Bolts
- (0) 10mm Flat Washers
- (2) 10mm Nylon Lock Nuts



(Fig 14) Attach Bull Bar and Brackets to inside if Mounting Brackets



(Fig 16) Only cut enough to clear the Brackets, do not cut through the front or rear edges of the cover.

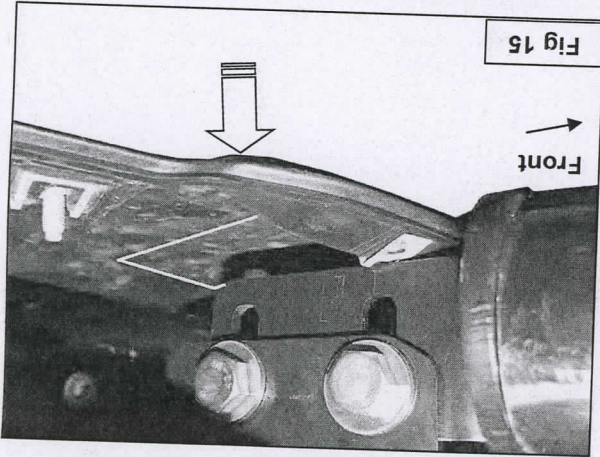
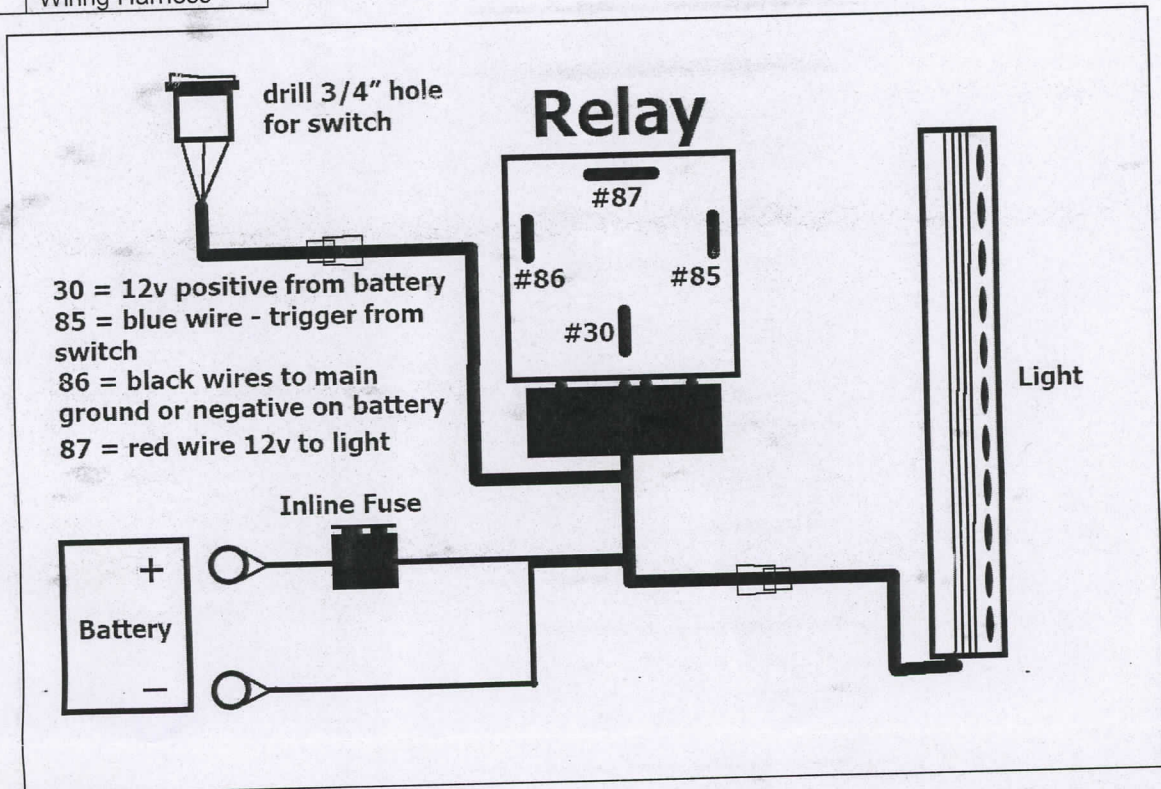


Fig 15

Hold the splash guard up to the bottom of the Brackets. Trace the location of the Brackets onto the inside of the splash guard. Use a sharp knife or hacksaw blade to cut out the plastic cover. Only cut enough to clear the Brackets, do not cut through the front or rear edges of the cover.

PARTS LIST:

| Qty | Description |
|-----|----------------|
| 1 | Light |
| 1 | Wiring Harness |



PROCEDURE:

1. REMOVE CONTENTS FROM BOX. VERIFY ALL PARTS ARE PRESENT. READ INSTRUCTIONS CAREFULLY. DRILLING IS REQUIRED. ELECTRICAL KNOWLEDGE IS HIGHLY RECOMMENDED.
2. Install Light into product as instructed. Open hood and disconnect battery.
3. Unwrap preassembled wiring harness. Disconnect the plug in the harness leading to the lighted switch. Locate suitable mounting location for switch. Drill 3/4" hole in panel to mount switch. **IMPORTANT:** Do not drill any holes in panel until back of location is properly checked for clearance. Use of safety goggles is required.
4. Run switch harness through firewall on vehicle. Drill hole through firewall as required for harness plug. Highly recommend use of rubber grommet (not included) to protect harness. Feed switch harness plug through hole in firewall. Seal firewall with silicone as necessary.
5. Attach Relay and main harness to suitable location near battery (firewall or inner fender for example). Do not connect to battery at this time.
6. Attach switch plug to switch harness and tie harness away from anything that could damage harness.
7. Run the prewired light harness down to the light. Plug harness into prewired plug on light. Tie wiring harness away from anything that could damage harness.
8. Attach the fused red positive and black negative wires on the main harness to the battery. **NOTE:** Attach black negative wire to negative terminal on battery or suitable chassis ground.
9. Reattach battery cables to battery. Installation is complete.
10. Do periodic inspections to the installation to make sure that all hardware is secure and tight and all wiring harnesses are properly secured and free from excessive movement.